

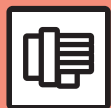

CHUCK

チャックシリーズ
CHUCK SERIES

kitagawa



ROTARY
CYLINDER

シリンダシリーズ
CYLINDER SERIES



WORK
GRIPPER

ワークグリッパシリーズ
WORK GRIPPER SERIES



CHUCK



ROTARY CYLINDER



WORK GRIPPER

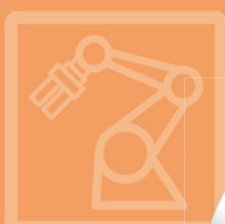

ウェブショールーム : <https://prod.kiw.co.jp/exhibition/mtools/>
Web showroom : <https://prod.kiw.co.jp/exhibition/mtools/en/>



日本語



English



CHUCK

INDEX

[掲載商品 Product Description]

チャック選定表 Chuck Selection Chart P. 3

スタンダードチャック Standard Chuck

高精度大貫通穴径中空パワーチャック
High Precision, Ultra-large Through-hole, High-speed Power Chuck P. 7
BR series

Tnut-Plus P. 9

自動ジョー交換システム
Automatic Jaw Change System P. 10
BR-AJC

BR-AJC Tナット
BR-AJC Tnut P. 11
BR-AJC_M

中空パワーチャック
Thru-Hole Power Chuck P. 12
B-200 series

中空パワーチャック(ショートテーパー)
Thru-Hole Power Chuck(Direct Mount) P. 13
B-200A series

中空パワーチャック
Thru-Hole Power Chuck P. 14
B series

中空パワーチャック(ショートテーパー)
Thru-Hole Power Chuck(Direct Mount) P. 15
B-A series

高精度中空パワーチャック
High Precision Thru-Hole Power Chuck P. 16
BS300 series

高精度中空パワーチャック(ショートテーパー)
High Precision Thru-Hole Power Chuck(Direct Mount) P. 17
BS300A series

中空ロングストロークパワーチャック
Long Stroke Power Chuck P. 18
BL-200 series

高速中空パワーチャック
Counter Balanced Power Chuck P. 19
HOH series

2爪高精度大貫通穴径中空パワーチャック
2-Jaw High-Precision, Ultra-large Through-hole Power Chuck P. 20
BRT series

2爪中空パワーチャック
2 Jaw Thru-Hole Power Chuck P. 21
BT200 series

2爪中空ロングストロークパワーチャック
2-Jaw Long Stroke Power Chuck P. 22
BLT200 series

クイックジョーチェンジチャック
Quick Jaw-Change Chuck P. 23
QB300 series

クイックジョーチェンジチャック
Quick Jaw Replacement Chuck P. 24
QJR series

中実パワーチャック
Closed Centre Power Chuck P. 25
N series

中実パワーチャック(ショートテーパー)
Closed Centre Power Chuck(Direct Mount) P. 26
N-A series

立形旋盤用大型チャック
Large Power Chuck for Vertical Lathes P. 27
NV series

2爪中実パワーチャック
2-Jaw Closed Center Power Chuck (NLT-Long Stroke) P. 28
NT・NLT series

中実ロングストロークパワーチャック
Closed Centre Power Chuck(Long Stroke) P. 29
NL series

中実ロングストロークパワーチャック(ショートテーパー)
Closed Centre Power Chuck(Long Stroke, Direct Mount) P. 30
NL-A series

中実超ロングストロークパワーチャック
Mega-Long Stroke Chuck P. 31
ML series

2爪中実超ロングストロークパワーチャック
2-Jaw Mega-Long Stroke Chuck P. 32
MLT series

1爪中実超ロングストロークパワーチャック
1-Jaw Mega-Long Stroke Chuck P. 33
MLV series

4爪中実パワーチャック
4-Jaw Lever Type Power Operated Chuck with Closed Centre P. 34
HW series

フロント中空エアチャック
Air-Operated Self Contained Chuck P. 35
UVE-K series

大口径フロント中空エアチャック
Air-Operated Self Contained Chuck P. 36
UPR series

大口径フロント中空エアチャック
Air-Operated Self Contained Chuck P. 37
UB series

シリンダ内蔵高速パワーチャック
Cylinder built-in high-speed power chuck P. 39
HRS series

精密中実エアチャック
High Precision Air Chuck P. 41
KPC series

アドバンスチャック Advanced Chuck

薄型デュアルロックチャック
Thin dual lock chuck P. 43
DLR series

デュアルロックチャック
Dual Lock Chuck P. 45
DL200 series

パワーウィングチャック
Power Wing Chuck P. 49
PW (C) series

2爪パワーウィングチャック
2-Jaw Power Wing Chuck P. 53
PWT (C) series

中空プルロックチャック
Open Centre Pull Lock Chuck P. 54
PUB series

プルロックチャック
Pull Lock Chuck P. 55
PU series

内径プルロックチャック
Internal Pull Lock Chuck P. 57
PUE series

レベルロックチャック
Level Lock Chuck P. 58
LU series

フィンガーチャック
Finger Chuck P. 59
FG(T) series

高剛性アルミホイール用フィンガーチャック
Finger Chuck for Automotive Wheels P. 61
FG-V series

アルミホイール用フィンガーチャック
Finger Chuck for Automotive Wheels P. 62
FG-L series

2輪アルミホイール用フィンガーチャック
Finger Chuck for motor cycle wheels P. 63
FG-M series

省段取りアルミホイール用フィンガーチャック
Easy Preparation Finger Chuck for Automotive Wheels P. 64
FG-Q series

 **ROTARY CYLINDER シリンダ Cylinder**

中空回転油圧シリンダ Next-Generation Hydraulic Cylinder with Large Through-Hole SR series	P. 67
中空回転油圧シリンダ Next-Generation Hydraulic Cylinder with Large Through-Hole SR_C series	P. 69
短寸中空回転油圧シリンダ Compact Hydraulic Cylinder with Large Through-Hole SS series	P. 71
中空回転油圧シリンダ Hydraulic Cylinder with Through-Hole S series	P. 73
中空回転油圧シリンダ (ロングストローク) Hydraulic Cylinder with Through-Hole and Long Stroke S-L series	P. 74
中空回転油圧シリンダ High-Speed Hydraulic Cylinder with Through-Hole F series	P. 75
クーラントコレクタ・確認装置 Coolant Collector Confirmation Device	P. 76
短寸中実回転油圧シリンダ Compact Hydraulic Cylinder with Non-Through-Hole M series	P. 77
中実回転油圧シリンダ Hydraulic Cylinder with Non-Through-Hole Y-R series	P. 79
中実回転油圧シリンダ (近接スイッチ取付可能仕様) Hydraulic Cylinder with Non-Through-Hole (proximity switches can be attached) Y-RE series	P. 80
中実回転油圧ダブルシリンダ Tandem Cylinder YW-R series	P. 81
中実回転エアシリンダ High-Speed Air Cylinder with Non-Through-Hole AY-R series	P. 82
ステーションナリシリンダ Stationary Cylinder YS series	P. 83

 **CHUCK ハンドチャック Manual Chuck**

一体爪スクロールチャック(ストレートインロー) Scroll Chuck with Integrated Jaw(Straight Recess) SC・JN series	P. 85
分割爪スクロールチャック(ストレートインロー) Scroll Chuck with 2 Piece Jaw (Straight Recess) JN-T series	P. 86
前面取付型スクロールチャック(ストレートインロー) Front Mounting Type Scroll Chuck (Straight Recess) SC・JN・JN-T・JN-TN series	P. 87
分割爪スクロールチャック(ショートテーパ) Scroll Chuck with 2 Piece Jaw (Direct Mount) JN-RA series	P. 88
2爪スクロールチャック(ストレートインロー) 2-Jaw Scroll Chuck (Straight Recess) JT series	P. 89
4爪スクロールチャック(ストレートインロー) 4-Jaw Scroll Chuck (Straight Recess) JS series	P. 90
インディペンデントチャック(ストレートインロー) Independent Chuck(Straight Recess) IC series	P. 91
インディペンデントチャック(ショートテーパ) Independent Chuck(Short Taper) IA series	P. 92

 **WORK GRIPPER ワークグリッパ Work Gripper**

ワークグリッパ Work Gripper AS series	P. 95
2爪ワークグリッパ 2-Jaw Work Gripper AT series	P. 97
パワーウイングワークグリッパ Power Wing Work Gripper PWS06	P. 99
内径プルロックワークグリッパ Internal Pull Lock Work Gripper PUES06	P.101
プルロックワークグリッパ Pull Lock Work Gripper PLS series	P.103
ジグモジュール Jig Module JM200	P.105
スクロールワークグリッパ Stationary Scroll Chuck SC-S series	P.107
オプション Option	P.109

 **CHUCK 部品・その他 Jaws and Accessories**

パワーチャック用ソフトジョー Soft Jaws for Power Chuck SJ series	P.111
パワーチャック用ハードジョー Hard Jaws for Power Chuck HB series	P.115
Tナット T-nut	P.116
スクロールチャック用ハードジョー Hard Jaws for Scroll Chuck HBS series	P.117
スクロールチャック用ソフトジョー Soft Jaws for Scroll Chuck SBS series	P.118
バックプレート Back Plate	P.119
カバーフタ Cover Cap	P.120
チャックグリース Chuck Grease Chuck Grease Pro	P.121
チャックグリース Chuck Grease Grease Nipple	P.123
静止型チャック把握力計 Jaw Force Tester JFT-S100A	P.124
DATA ショートテーパチャックの旋盤適合表 Compatibilities of Lathes to Short Taper Chucks	P.125
旋盤主軸端とショートテーパチャック取付けについて For mounting a directly-mounted type chuck to lathe spindle end	P.131
スクロールチャックのパーツご注文に際して For order of Scroll Chuck parts	P.133



CHUCK

チャック選定表 Chuck Selection Chart

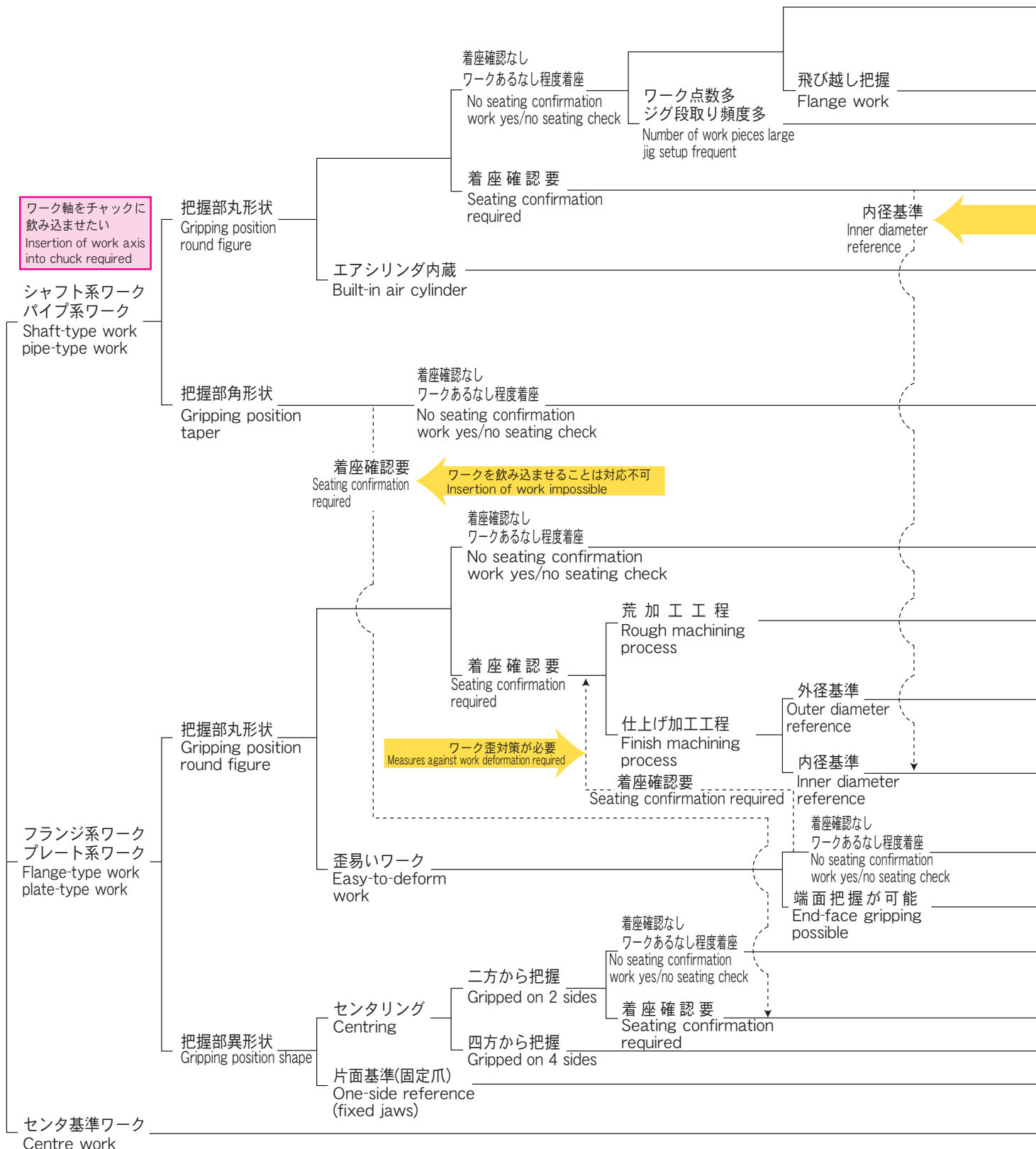

カタログ Catalogue	チャックサイズ (インチ) Chuck Size (Inches)											
	掲載ページ Page	3	4	5	6	8	10	12	15	18	21	24
高把握精度 High gripping accuracy	P.7				○	○	○	○				
ジョー浮上り軽減 Jaw floating reduction	P.16				○	○	○					
高速回転必要 High-speed rotation required	P.19				○	○	○	○	○			
	P.12~15		○	○	○	○	○	○	○	○	○	○
	P.18				○	○	○	○				
	P.23				○	○	○	○				
	P.24					7・8	○	○				
	P.54				○	○	○					
安定把握精度 Stable chucking accuracy	P.35	※商品ページをご覧ください ※Refer to the product page.										
UB	P.37	※商品ページをご覧ください ※Refer to the product page.										
UPR	P.36	※商品ページをご覧ください ※Refer to the product page.										
BRT	P.20				○	○	○	○				
BLT200	P.22				○	○	○	○				
BT200	P.21		○	○	○	○	○	○				
HRS	P.39					○						
N	P.25		○	○	○	○	○	○	○	○	○	○
NV	P.27	※商品ページをご覧ください ※Refer to the product page.										
NL	P.29		○		○	○	○	○		○		
ML	P.31				○	○						
PW	P.49				○	○	○	○	○			
安定把握精度 Stable chucking accuracy	P.55	○	○	○	○	○	○	○				
LU	P.58				○	○	○	○				
DLR	P.43					○						
DL200	P.45				○	○	○	○				
安定把握精度 Stable chucking accuracy	P.57			○	○	○						
KPC	P.41	※商品ページをご覧ください ※Refer to the product page.										
FG	P.59			○	○	○	○	○				
NT/NLT	P.28		○	○	○	○	○	○	○			
MLT	P.32				○	○						
PWT	P.53				○	○	○	○	○			
HW	P.34					○	○	○	○			
MLV	P.33				○	○						
PW-C	P.49				○	○	○	○	○		○	
PWT-C	P.53				○	○	○	○	○			

※改良等の理由によって、予告なく変更することがあります。
 ※The contents in this chart are subject to change without notice for further improvement, etc.



CHUCK

kitagawa

技術を研ぎ澄ます 世界が認めた信頼のブランド Universally recognised and trusted brand offering proven technology

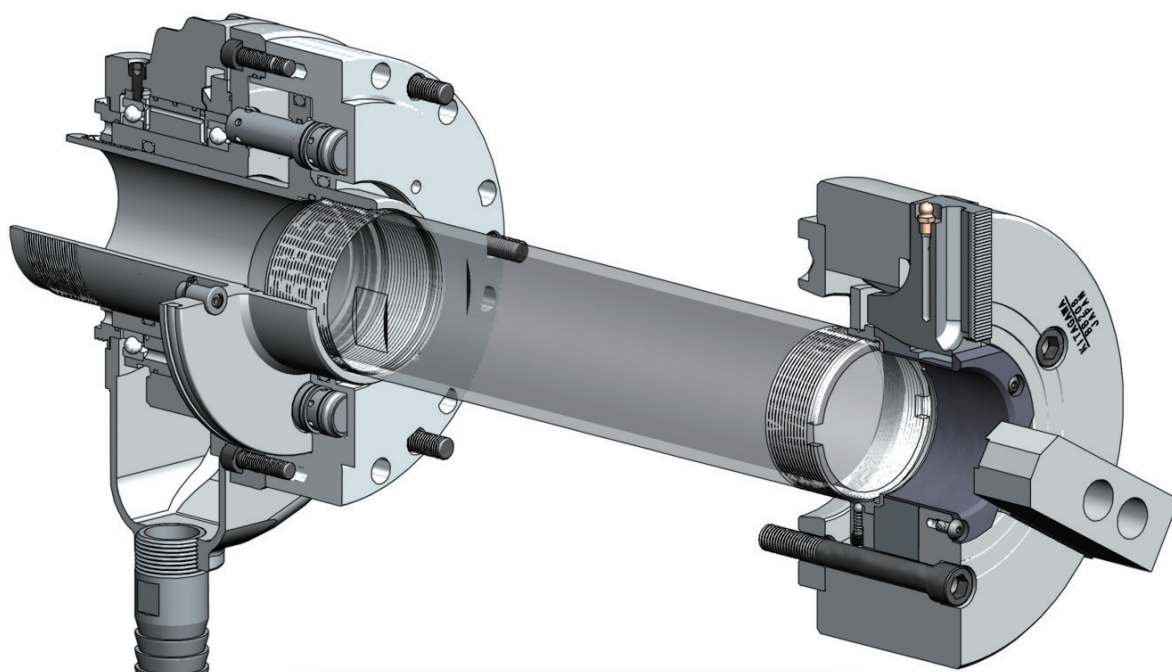

半世紀以上もの間、世界中のお客様より高い信頼をいただいているKITAGAWAチャック。それは、高精度・高品質な商品を厳しく品質管理し、安心してご使用いただける製造体制によります。

進化し続ける最先端のチャッキングテクノロジーであらゆる加工条件に、フレキシブルに対応するチャックシリーズ。幅広いバリエーション、きめ細やかな対応、独自のノウハウに裏付けられた技術を誇り、ワークホールディングで未知なる世界に挑戦します。

For over half a century, KITAGAWA products have inspired confidence in customers all over the World. The Kitagawa series of chucks is wide-ranging and so technologically advanced that we can offer solutions for all machining conditions, no matter how punishing. Manufacturing systems with exceptional quality controls ensure the production of highly precise and superior products, which guarantee trouble-free operation. Our unique innovations in workholding solutions, supported by highly specialised design teams and a proven history of excellence, shows our capacity to challenge the world of engineering.

**CHUCK**

▶ P.7~P.41

スタンダードチャック Standard Chuck

世界の標準的定番 パワーチャックシリーズ Standard power chucks that are the global standard

豊富なバリエーションを持つスタンダードチャック。
世界のスタンダードチャックであるジョー平行移動型の中空タイプ、
中実タイプからエアシリンダ内蔵型のアアチャック。標準タイプの
チャックを利用したワーク対応設計。
あらゆる要求に対応できる幅広いラインアップと独自のノウハウで最
適なワークホールディングを提案します。

We offer a wide variety of standard chucks, including through-hole,
non-through-hole power chucks, and air-operated chucks with
built-in air cylinders.

With our extensive lineup and unique expertise, we offer optimal
workholding solutions.



CHUCK

高精度大貫通穴径中空パワーチャック High Precision, Ultra-large Through-hole, High-speed Power Chuck BR series

特許第6411619号 Pat. No. 6411619
特許第6345321号 Pat. No. 6345321

常識を覆す次世代の標準チャック

The next generation standard chuck

ジョー成形直後の把握精度0.01mm T.I.R.以下。*

Gripping accuracy of 0.01mm T.I.R. or less immediately after jaw forming.*

*CE対応品 *CE corresponding



Next Generation
Standard Chuck **BR**
SERIES

2021年度日本機械学会賞(技術)受賞
Received the 2021 JSME Award (Technology)

- 常識を超える0.01mm T.I.R.以下の把握精度。*
標準チャックの常識を覆す把握精度により仕上げ加工にも最適。

Gripping accuracy of 0.01mm T.I.R. or less*
Unprecedented high gripping accuracy of standard chuck is also suitable for finish machining.

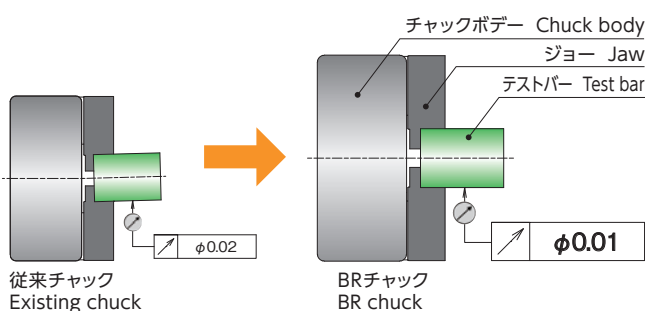

- 安定した加工品質
ジョーの浮き上がりの低減により安定した加工品質を実現します。

Stable machining quality
Reduced jaw-lift provides stable machining quality.

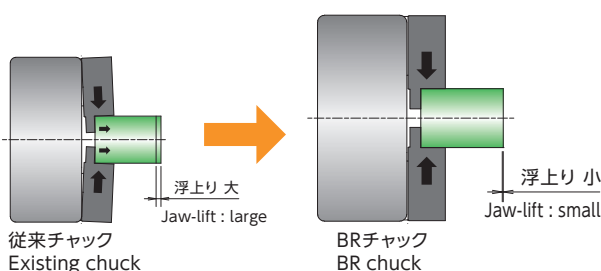

- 当社のB-200、BB200チャックとの取付互換。
既存のシリンダが使用可能で、最小のコストで最高の性能を導入いただけます。

Interchangeable with Kitagawa B-200 and BB200 series.
Continued use of the currently used rotary hydraulic cylinder allows you to implement the best performance at the lowest cost.

*BR12では、把握精度は0.015mmT.I.R.となります。
*Only for BR12, the gripping accuracy is 0.015mmT.I.R.

- オプションの特殊Tナットの使用でさらに高精度に。
Tnut-Plusの使用によりジョーの再成形が不要。
ジョー脱着後の把握精度0.01mm T.I.R.以下を実現。*

当社標準ソフトジョー (SJ形) を使用可能。
高い再現性は当社製のソフトジョーでのみ実現できます。
他社製のジョーでは再現精度が悪化したり、チャック摺動面の焼付きや部品損傷が発生したりする恐れがあります。
ジョーの取付再現性が非常に高いため、高価な特殊ジョーは不要です。

With the optional special T-nuts, it will become more accurate.

Use of the optional Tnut-Plus eliminates the need for jaw reforming.

Gripping accuracy 0.01mm T.I.R. or less even detaching and attaching formed jaws.*

Kitagawa standard soft jaws (SJ) are usable.
High repeatability can be realized only with Kitagawa genuine soft jaws. Use of jaws manufactured by a third party may cause deterioration of repeatability, sliding surface seizure or damage to parts.
Due to high accuracy of jaw mounting expensive special jaws are not needed.

*Tnut-Plusの詳細はP9をご確認ください。

*See page 9 about Tnut-Plus.

オプションの特殊Tナット
Optional special Tnut

Tnut-Plus

特許第6345375号
Pat. No. 6345375



BRチャックを使いこなす To master BR series

- BRチャック専用サイト
Special website for BR chuck

BRchuck.com



日本語



English

- 動画で特徴をご案内
Introducing with video



日本語



English

■ 寸法図 Dimensional Drawings

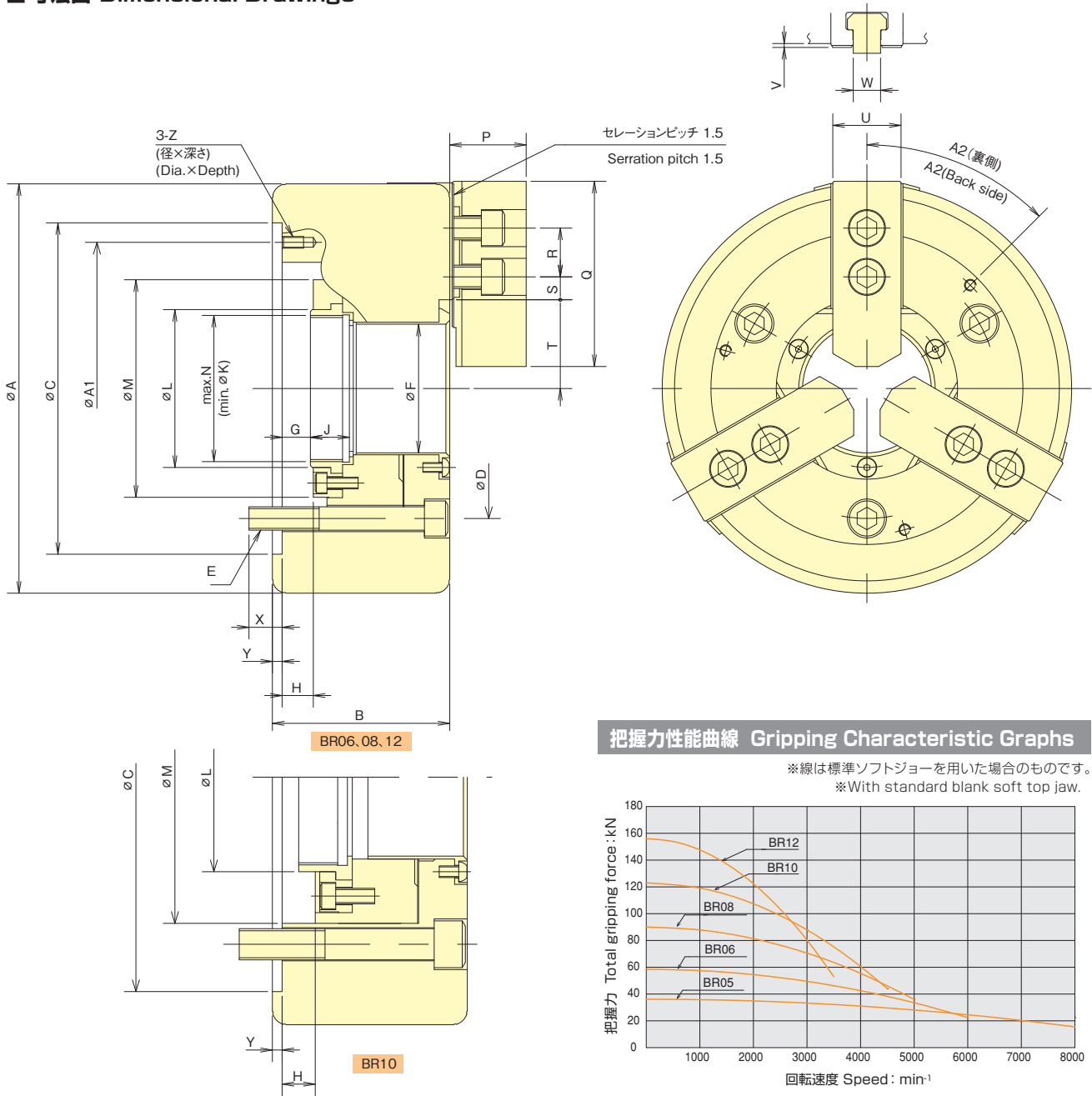

スタンダードチャック
Standard Chuck

把握力性能曲線 Gripping Characteristic Graphs

※線は標準ソフトジョーを用いた場合のもので、
※With standard blank soft top jaw.

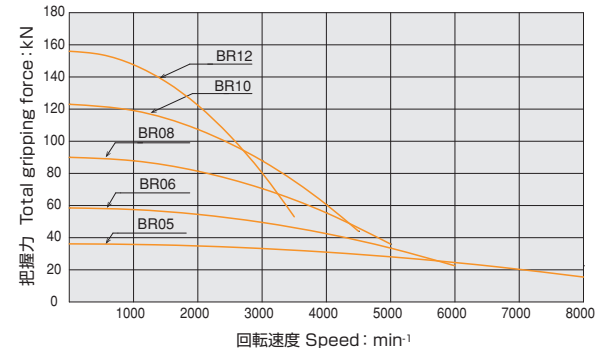

■ 寸法表 Dimensions ※ドローナットのねじは未加工です。※Blank draw nut equipped.

型式 Model	A	B	C (H6)	D	E	F	G max.	G min.	H max.	H min.	J	K	L	M	N max.	P	Q	R	S max.	S min.	T max.	T min.	U	V	W	X	Y	Z	A1	A2
BR05	135	60	110	82.6	3-M10	33	1	-9	10	0	20	12	45	68.7	M40x1.5	26	54	14	20.75	4.25	26.6	23.9	23	1.8	10	15	4	M6x12	96	30°
BR06	170	81	140	104.8	3-M10	53	11	-1	12	0	17.5	20	66	89.7	M60x2	33.2	72	20	21.25	9.25	36.05	33.3	31	2	12	16	5	M6x11	116	90°
BR08	210	91	170	133.4	3-M12	66	14.5	-1.5	16	0	20	30	81	111.6	M75x2	39.2	95	25	23.75	11.75	45.5	41.8	35	2	14	17	5	M6x11	150	45°
BR10	254	100	220	171.4	3-M16	81	8.5	-10.5	19	0	25	45	97	150	M90x2	43.2	110	30	32.25	11.25	54	49.6	40	2	16	22	5	M8x15	190	75°
BR12	315	108	300	235	3-M20	106	8	-15	23	0	28	50	124	166.7	M115x2	52	111	30	45.75	12.75	68.8	63.5	50	2.8	21	29	6	M10x16	260	75°

■ 仕様表 Specifications ※把握径/把握範囲は標準のソフトジョーを使用した場合。※Gripping dia./ Gripping range is with standard jaws.

型式 Model	貫通穴径 Thru-Hole mm	把握径 Gripping range mm	ジョーストローク (値図) Jaw Stroke (diagram) mm	プランジャストローク Plunger Stroke mm	許容最高回転速度 Max. Speed min⁻¹	許容最大入力 Max. Draw Bar Pull Force kN	最大静的把握力 Max. Gripping Force kN	最高回転時の動的把握力 Dynamic gripping force at max. speed kN	質量 Net Weight kg	慣性モーメント Moment of inertia kg·m²	適合シリンダ Matching Cylinder	許容最大油圧力 Max. pressure MPa	標準ソフトジョー Matching Soft top jaw
BR05	33	135 7	5.4	10	8000	16.6	36	15.5	6.2	0.015	F0933H	3.3	SJ05N1
BR06	53	170 16	5.5	12	6000	23	58.5	22.5	12.8	0.052	SR1453	2.3	SJ06B1
											SS1453K	2.1	
BR08	66	210 22	7.4	16	5000	35	90	36	22.2	0.14	SR1566	3.2	SJ08B1
											SS1666K	2.5	
BR10	81	254 31	8.8	19	4500	49	123	44	35.8	0.32	SR1781	3.4	SJ10B1
											SS1881K	3.1	
BR12	106	315 44	10.6	23	3500	60	156	53	57.0	0.80	SS2110K	3.0	SJ12N1

※質量・慣性モーメントは取付ボルト、ソフトジョーを含んだもので、マスタージョー位置はストローク中央、ソフトジョー位置は外形図に記載の取り付け位置として計算しています。

※The weight and the moment of inertia include mounting bolts and soft jaws.
The calculation is assuming that the master jaws are at the centre of stroke and soft jaws are at as of the outline drawing.



CHUCK

Tnut-Plus

Tnut-Plusの使用によりジョーの再成形が不要
ジョー脱着後の把握精度0.01mm T.I.R.以下を実現
Use of the optional Tnut-Plus eliminates the
need for jaw reforming. Gripping accuracy
0.01mm T.I.R. or less even detaching
and attaching formed jaws.



- ジョー交換後の再成形が不要のため段取替え時間を大幅に短縮可能。
Needless of reforming after jaw replacement greatly reduces setup time.
- 当社標準ソフトジョー (SJ形) を使用可能。
Kitagawa standard soft jaws (SJ) are usable.
- ジョーの取付再現性が非常に高いため、特殊ジョーは不要です。
Due to high accuracy of jaw mounting special jaws are not needed.
- 高い再現性は当社製のソフトジョーでのみ実現できます。他社製のジョーでは再現精度が悪化したり、チャック摺動面の焼付きや部品損傷が発生したりする恐れがあります。
High repeatability can be realized only with Kitagawa genuine soft jaws. Use of jaws manufactured by a third party may cause deterioration of repeatability, sliding surface seizure or damage to parts.

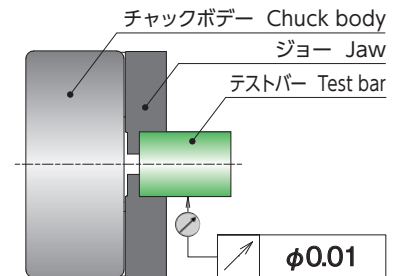

※BR/BRT12では、把握精度は0.015mmT.I.R.となります。
 ※Only for BR/BRT12, the gripping accuracy is 0.015mmT.I.R.

Tnut-Plus 適応表、寸法表 Tnut-Plus Dimensions and Combination

型式 Model	T-1	T-2	T-3	T-4	T-5	T-6	T-7	T-8	T-9	適応チャック型式 Adaptive chuck	参考図 Ref. DWG.
TN05PLUS	26.5	14.1	15.5	10	14	6	10	M8	5	BR05	1
TN06PLUS	36.5	17.5	19	12	20	8.25	11.5	M10	9	BR06, BRT06, HRS08, DLR08	1
TN08PLUS	46.5	20.5	21	14	25	10.5	12.5	M12	12	BR08, BRT08	1
TN10PLUS	52	22.5	22	16	30	11	13.5	M12	11	BR10, BRT10	1
TN12PLUS	56.25	29.5	23.5	21	30	12	12	M16	14	BR12, BRT12	1

適応チャックシリーズ Applicable chuck series

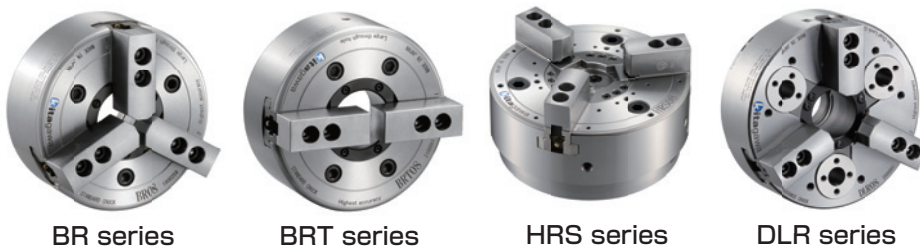

参考図1 Ref. DWG. 1

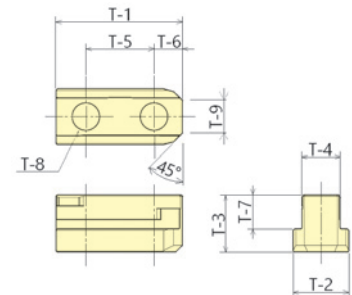

※T-8はソフトジョー取付ボルトサイズです。
 ※T-8 is the size of soft jaw mounting bolt.



CHUCK

自動ジョー交換システム Automatic Jaw Change System BR-AJC

高精度な次世代スタンダードチャック BRシリーズを用いた自動ジョー交換システム

Automatic Jaw Change system using higher-accurate next generation standard chuck BR series.

- ジョーを脱着しても把握精度0.01mm T.I.R.以下
High gripping accuracy of 0.01 mm T.I.R. or less after changing jaws
- チャック本体はBR/BRTシリーズをそのまま使用できる為、
イニシャルコストが大幅に削減される
The BR/BRT series chuck can be used without modification,
the initial cost is greatly reduced
- 従来システムよりも切粉の清掃が容易
Easier to clean chips than conventional systems

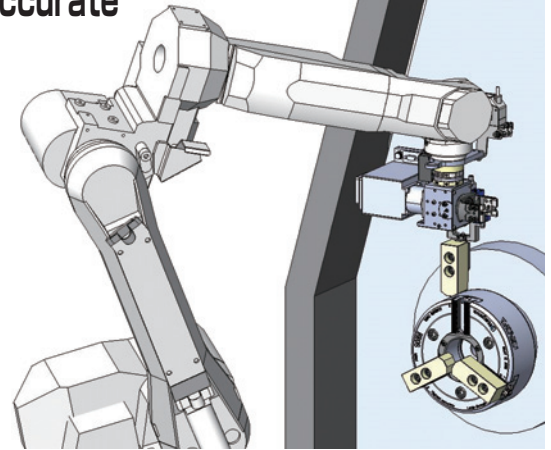

スタンダードチャック

自動化に向け段階的な導入が可能 It can be phased in for automation

BR/BRTシリーズを採用
Select BR/BRT series



BR-AJC-Mを使用し、
ジョーの手動交換をスピードアップ!
Using BR-AJC_M,
Speed up manual jaw replacement!



ロボットでのジョー自動交換を行う際に、
BR/BRTシリーズをそのまま使用可能!
When starting automatic jaw exchange with a robot,
BR/BRT series can be used as is.

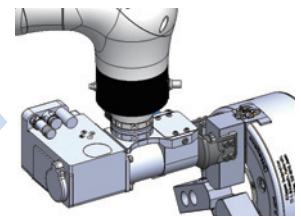

効果 Effectation

- ・安定した加工品質
Stable machining quality
- ・ジョーの再成形が不要
No need to reform the jaws.

※詳しくはP.7、9、20をご覧ください。
*Please see page 7, 9, 20 for details.

- ・セレーションの山を数えなくてよい
No need to counting the number of serrations
- ・ジョー取付位置の間違いがない
Preventing position error at jaw mounting

※詳しくはP.11をご覧ください。
*Please see page 11 for details.

- ・自動化・省人化
Automation/labor saving



CHUCK

BR-AJC Tナット BR-AJC Tnut BR-AJC_M



BR/BRTがクイックジョーチェンジチャックにアップグレード

Upgrade existing BR/BRT chuck to quick jaw change

- 既存のBR/BRTチャック、ソフトジョーをそのまま使用してクイックジョーチェンジチャックにできます。
Existing BR/BRT chucks and soft jaws can be used as is for quick jaw change.
- セレーション位置の取付間違いがなく、誰が取り付けても同じセレーション位置になります。
There is no installation mistake in the serration positioning, no matter who replaces the jaws.
- ジョーを脱着しても把握精度は0.01mm T.I.R.です。ジョー交換時に再成形は不要です。^{注)}
Gripping accuracy is 0.01mm T.I.R. even when the jaws are detached and attached. No jaw reforming required.^{Note)}

注) BR/BRT12では、把握精度は0.015mm T.I.R.となります。 Note) 12 inch only has 0.015mm T.I.R.

■使用方法 How to use

ジョーをあらかじめ機上成形し、位置決めナットをマスタージョーに当たるまでねじ込んでロックすることで事前のセット完了です。

The setting is completed by forming the jaws on the lathe and screwing the positioning nut until it hits the end of master jaw and then locking it.

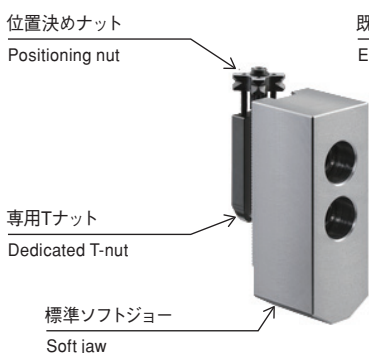
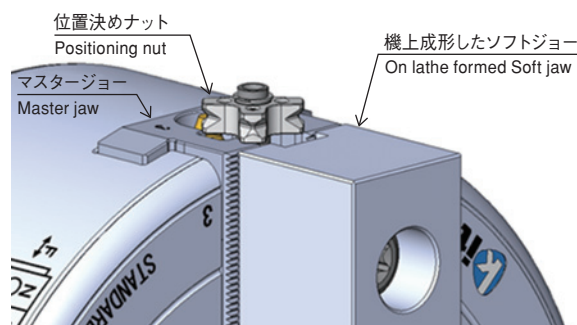

あらかじめ成形して位置決めナットがセット済みのソフトジョー

The soft jaw pre-formed and fitted with positioning nuts

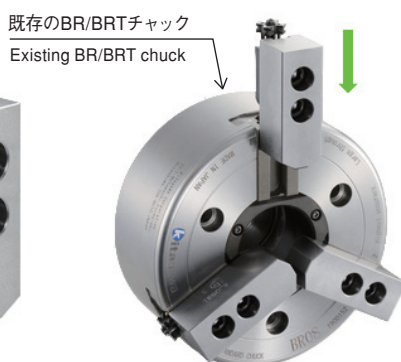

セット済みのソフトジョーをマスタージョーに挿入

Insert the T-nut with soft jaw set into the master jaw

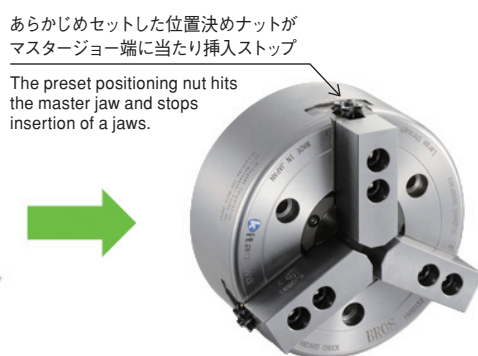

あらかじめセットした位置決めナットがマスタージョー端に当たり挿入ストップ
The preset positioning nut hits the master jaw and stops insertion of a jaws.

位置決めナットがマスタージョーに当たった位置でジョー取付ボルトを締めるだけ

Simply tighten the jaw mounting bolts at the position where the positioning nut hits the master jaw

型式 Type	対応チャック Chuck model
BR-AJC06M	BR06/BRT06
BR-AJC08M	BR08/BRT08
BR-AJC10M	BR10/BRT10
BR-AJC12M	BR12/BRT12

手動交換でも素早い段取り替えが可能
Quick changeover is possible even with manual changeover



CHUCK

中空パワーチャック Thru-Hole Power Chuck B-200 series

世界が認めたスタンダードチャック World Renowned Standard chuck

*CE対応品 *CE corresponding



スタンダードチャック
Standard Chuck

■ 寸法図 Dimensional Drawings

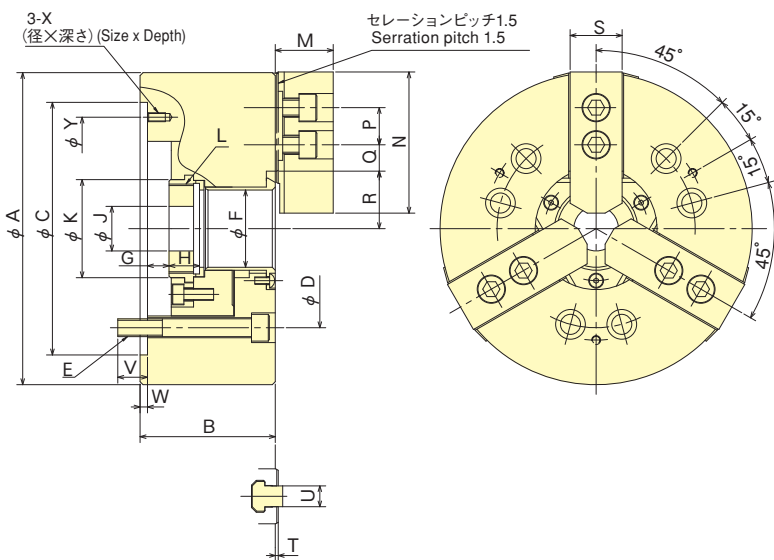

把握状態例 Gripping Example

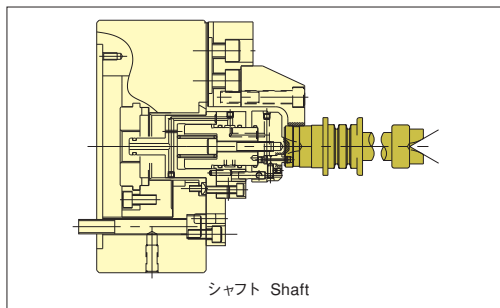

把握力性能曲線 Gripping Characteristic Graphs

※線は標準ソフトジョーを用いた場合のもので、
※With standard blank soft top jaw.

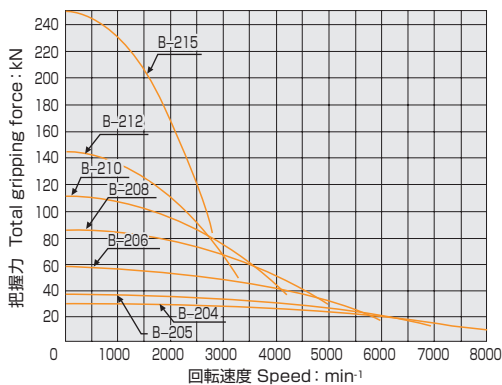

■ 寸法表 Dimensions

※B-204, 205の取付 120°ピッチ 3本 ※ドローナットのねじは未加工です。
※Mounting Bolt P. C. D for B-204 & B-205 : 120° Pitch : 3pcs. ※Blank draw nut equipped.

型式 Model	A	B	C (H6)	D	E	F	G max.	G min.	H	J	K	L max.	M	N	P	Q max.	Q min.	R max.	R min.	S	T	U	V	W	X	Y
B-204	110	59	85	70.6	3-M10	26	3.5	- 6.5	17.5	12	38	M32×1.5	24	49.5	14	11.25	6.75	23	20.3	23	2	10	15.5	4	-	-
B-205	135	60	110	82.6	3-M10	33	1	- 9	20	12	45	M40×1.5	26	54	14	19.75	7.75	26.5	23.8	23	2	10	15	4	-	-
B-206	169	81	140	104.8	6-M10	45	11	- 1	19	20	60	M55×2	29	66	20	22.75	9.25	32	29.25	26	2	12	16	5	M6×10	116
B-208	210	91	170	133.4	6-M12	52	14.5	- 1.5	20.5	30	66	M60×2	39	95	25	29.75	14.75	38.7	35	35	2	14	20	5	M6×12	150
B-210	254	100	220	171.4	6-M16	75	8.5	-10.5	25	45	94	M85×2	43	110	30	33.75	14.25	51	46.6	40	2	16	22	5	M8×15	190
B-212	304	110	220	171.4	6-M16	91	8	-15	28	50	108	M100×2	51	111	30	45.75	15.75	61.3	56	50	2	21	23	6	M8×15	190
B-215	381	147	300	235	6-M20	100	23	0	35	50	120	M110×2	61	135	43	54.75	20.25	70	64.7	50	2	25.5	31	6	M10×16	260

■ 仕様表 Specifications

※許容最高回転速度は、実測値によります。※Max. speed is shown using actual test data.
※把握径/把握範囲は標準のソフトジョーを使用した場合。※Gripping dia./gripping range is with standard soft jaws.

仕様 型式 Model	貫通孔径 Thru-Hole mm	把握径 Gripping range mm	ジョーストローク (直径) Jaw Stroke (diameter) mm	プランジャストローク Plunger Stroke mm	許容最大入力 Max. Draw Bar Pull Force kN	最大静的把握力 Max. Gripping Force kN	許容最高回転速度 Max. Speed min ⁻¹	質量 (標準ソフトジョー) Net Weight with Soft top jaws kg	慣性モーメント Moment of inertia kg·m ²	適合シリンダ Matching Cylinder	許容最大油圧 Max. pressure MPa	適合ハードジョー Matching Hard top jaw	標準ソフトジョー Matching Soft top jaw
B-204	26	110 7	5.4	10	14	28.5	8000	4.0	0.007	F0933H	2.80	HB04N1	SJ04N1
B-205	33	135 12	5.4	10	17.5	36	7000	6.7	0.018	F0933H	3.43	HB04N1	SJ05N1
B-206	45	169 16	5.5	12	22	57	6000	11.9	0.058	S1246	2.8	HB06B1	SJ06L1A
B-208	52	210 13	7.4	16	34.8	86	5000	22.3	0.170	S1552	2.65	HB08A1	SJ08B1
B-210	75	254 31	8.8	19	43	111	4200	34.5	0.315	S1875	2.70	HB10A1	SJ10B1
B-212	91	304 34	10.6	23	55	144	3300	55.3	0.738	S2091	2.70	HB12N1	SJ12N1
B-215	100	381 50	10.6	23	98	249	2800	116.0	2.20	F2511H	3.30	HB15N1	SJ15N1



CHUCK

中空パワーチャック (ショートテーパ) Thru-Hole Power Chuck (Direct Mount) B-200A series

スピンドルノーズ対応バックプレート付き Equipped with Chuck Adaptor to suit Spindle Nose 世界が認めたスタンダードチャック Universally recognised standard chuck

*CE対応品 *CE corresponding



■ 寸法図 Dimensional Drawings

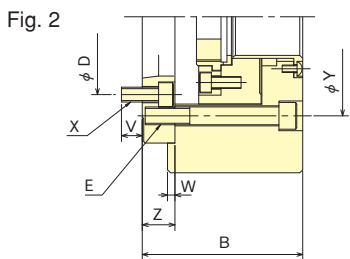
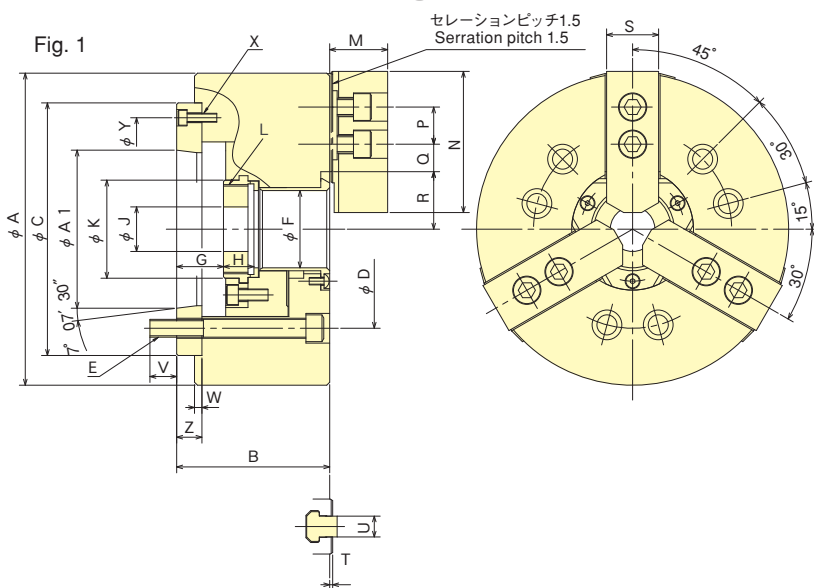

把握状態例 Gripping Example

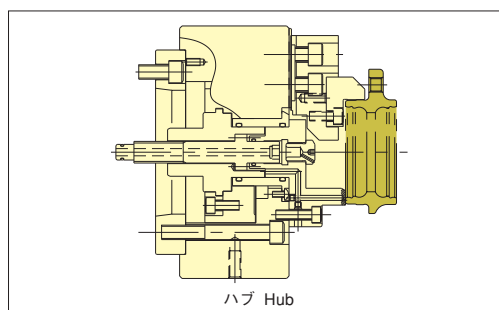

把握力性能曲線 Gripping Characteristic Graphs

※線は標準ソフトジョーを用いた場合のもので、
※With standard blank soft top jaw.

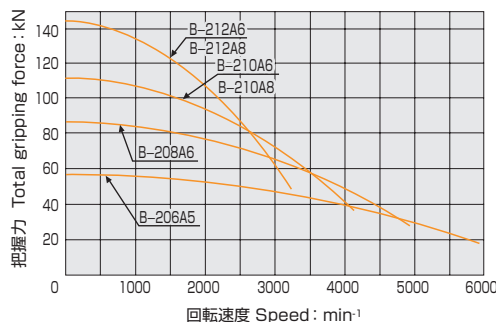

■ 寸法表 Dimensions

※B-210A6、B-212A6はFig.2参照。 ※ドローナットのねじは未加工です。
※B-210A6、B-212A6 are referred to in Fig.2. ※Blank draw nut equipped.

型式 Model	A	B	C	D	E	F	G max.	G min.	H	J	K	L max.	M	N	P	Q max.	Q min.	R max.	R min.	S	T	U	V	W	X	Y	Z	A1
B-206A5	169	91	140	104.8	6-M10	45	26	14	19	20	60	M5×2	29	66	20	22.75	9.25	32	29.25	26	2	12	16	5	3-M6	116	15	82.563
B-208A6	210	103	170	133.4	6-M12	52	31.5	15.5	20.5	30	66	M6×2	39	95	25	29.75	14.75	38.7	35	35	2	14	18	5	3-M6	150	17	106.375
B-210A6	254	120	220	133.4	6-M16	75	33.5	14.5	25	45	94	M8×2	43	110	30	33.75	14.25	51	46.6	40	2	16	18.5	5	6-M12	171.4	25	106.375
B-210A8	254	113	220	171.4	6-M16	75	26.5	7.5	25	45	94	M8×2	43	110	30	33.75	14.25	51	46.6	40	2	16	24	5	3-M8	190	18	139.719
B-212A6	304	129	220	133.4	6-M16	91	33	10	28	50	108	M9×2	51	111	30	45.75	15.75	61.3	56	50	2	21	18.5	6	6-M12	171.4	25	106.375
B-212A8	304	122	220	171.4	6-M16	91	26	3	28	50	108	M10×2	51	111	30	45.75	15.75	61.3	56	50	2	21	25	6	3-M8	190	18	139.719

■ 仕様表 Specifications

※許容最高回転速度は、実測値によります。 ※Max. speed is shown using actual test data.
※把握径/把握範囲は標準のソフトジョーを使用した場合。 ※Gripping dia./gripping range is with standard soft jaws.

仕様 型式 Model	貫通孔径 Thru-Hole mm	把握径 Gripping range mm	ジョーストローク (直径) Jaw Stroke (diameter) mm	プランジャストローク Plunger Stroke mm	許容最大入力 Max. Draw Bar Pull Force kN	最大静的把握力 Max. Gripping Force kN	許容最高回転速度 Max. Speed min ⁻¹	慣性モーメント (標準ソフトジョー) Moment of inertia kg·m ²	適合シリンダ Matching Cylinder	許容最大油圧 Max. pressure MPa	適合ハードジョー Matching Hard top jaw	標準ソフトジョー Matching Soft top jaw	主軸端呼び Spindle nose size
B-206A5	45	169 16	5.5	12	22	57	6000	13.7	0.063	2.8	HB06B1	SJ06L1A	A2-5
B-208A6	52	210 13	7.4	16	34.8	86	5000	23.6	0.178	2.65	HB08A1	SJ08B1	A2-6
B-210A6	75	254 31	8.8	19	43	111	4200	41.5	0.325	2.7	HB10A1	SJ10B1	A2-6
B-210A8	75	254 31	8.8	19	43	111	4200	40.0	0.323	2.7	HB10A1	SJ10B1	A2-8
B-212A6	91	304 34	10.6	23	55	144	3300	67	0.780	2.7	HB12N1	SJ12N1	A2-6
B-212A8	91	304 34	10.6	23	55	144	3300	64	0.765	2.7	HB12N1	SJ12N1	A2-8



CHUCK

中空パワーチャック Thru-Hole Power Chuck

B series

**大きなワークも安定加工
Stable Machining for Large Work-piece**
**世界が認めた大型スタンダードチャック
Universally recognised standard chuck**



スタンダードチャック

- 貫通穴径 Through-hole
15インチ φ117.5・18インチ φ117.5
21インチ φ140.0・24インチ φ165.0
15inch φ117.5・18inch φ117.5
21inch φ140.0・24inch φ165.0

*CE対応品 *CE corresponding

■寸法図 Dimensional Drawings

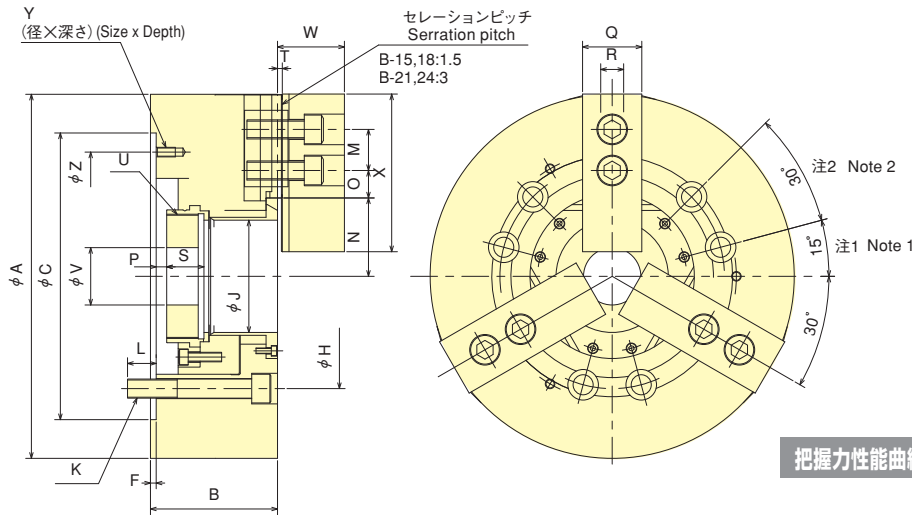

把握力性能曲線 Gripping Characteristic Graphs

※線は標準ソフトジョーを用いた場合のもので、
※With standard blank soft top jaw.

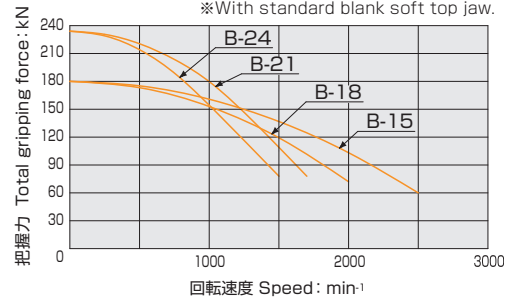

■寸法表 Dimensions ※ドローナットのねじは未加工です。 ※Blank draw nut equipped.

寸法 Dimensions Model	A	B	C (H6)	F	H	J	K	L	M	N max.	N min.	O max.	O min.	P max.	P min.	Q	R	S	T	U max.	V	W	X	Y	Z
B-15	381	133	300	6	235	117.5	6-M20	30	43	82	76.7	43.75	18.25	11	-12	62	22	39	5	M130×2	60	70	165	M10×20	260
B-18	450	133	380	6	235	117.5	6-M20	30	43	82	76.7	78.25	18.25	11	-12	62	22	39	5	M130×2	60	70	165	M10×20	320
B-21	530	140	380	6	330.2	140	6-M22	31	60	98.5	93.2	87.5	21.5	11	-12	65	25	39	5	M155×3	80	73	180	M12×30	330.2
B-24	610	149	380	6	330.2	165	6-M22	32	60	108	102.7	117.5	21.5	20	-3	65	25	40.5	5	M175×3	80	73	180	M12×25	330.2

■仕様表 Specifications ※把握径/把握範囲は標準のソフトジョーを使用した場合。 ※Gripping dia./gripping range is with standard soft jaws.

仕様 Specifications Model	貫通穴径 Thru-Hole mm	把握径 Gripping range mm Jaw Stroke(diameter) mm		プランジャストローク Plunger Stroke mm	許容最大入力 Max. Draw Bar Pull Force kN	最大静的把握力 Max. Gripping Force kN	許容最高回転速度 Max. Speed min ⁻¹	質量(標準ソフトジョー付) Net Weight with Soft top jaws kg	慣性モーメント Moment of inertia kg·m ²	適合シリンダ Matching Cylinder	許容最大油圧 Max. pressure MPa	適合ハードジョー Matching Hard top jaw	標準ソフトジョー Matching Soft top jaw
B-15	117.5	381	30	10.6	23	71	180	2500	120	2.273	F2511H	2.3	HB15A1 SJ15C1
B-18	117.5	450	30	10.6	23	71	180	2000	164	4.451	F2511H	2.3	HB15A1 SJ15C1
B-21	140	530	87	10.6	23	90	234	1700	235	8.95	F2511H	3.0	HB18B2 SJ18A2
B-24	165	610	109	10.6	23	90	234	1400	293	16.60	F2511H	3.0	HB18B2 SJ18A2



CHUCK

中空パワーチャック (ショートテーパ) Thru-Hole Power Chuck (Direct Mount) B-A series

スピンドルノーズ対応バックプレート付き
Equipped with Chuck Adaptor to suit Spindle Nose
世界が認めた大型スタンダードチャック
Universally recognised standard chuck

*CE対応品 *CE corresponding



スタンダードチャック

■ 寸法図 Dimensional Drawings

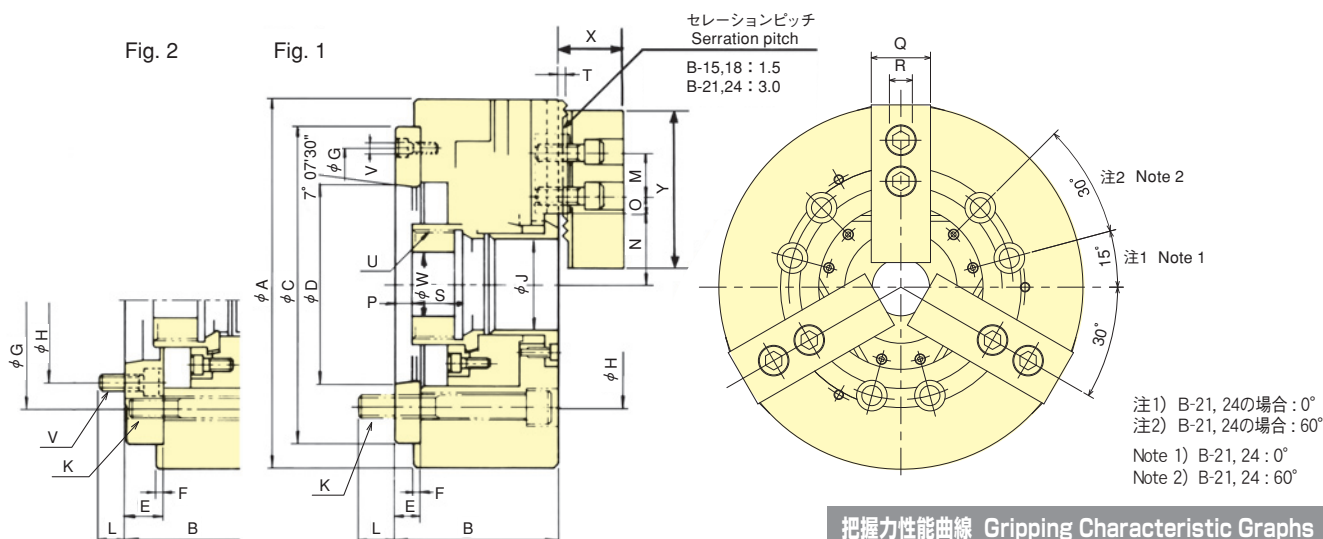

把握力性能曲線 Gripping Characteristic Graphs

※線は標準ソフトジョーを用いた場合のものです。
※With standard blank soft top jaw.

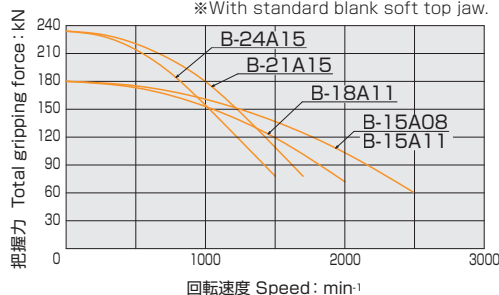

■ 寸法表 Dimensions

※B-15A08はFig.2参照。 ※ドローナットのねじは未加工です。
※B-15A08 is referred to in Fig.2. ※Blank draw nut equipped.

寸法 型式 Model	A	B	C	D	E	F	G	H	J	K	L	M	N max.	N min.	O max.	O min.	P max.	P min.	Q	R	S	T	U max.	V	W	X	Y
B-15A08	381	160	300	139.719	33	6	235	171.4	117.5	6-M20	24	43	82	76.7	43.75	18.25	44	21	62	22	39	5	M130×2	6-M16	60	70	165
B-15A11	381	149	300	196.869	22	6	260	235	117.5	6-M20	28	43	82	76.7	43.75	18.25	33	10	62	22	39	5	M130×2	3-M10	60	70	165
B-18A11	450	149	380	196.869	22	6	320	235	117.5	6-M20	28	43	82	76.7	78.25	18.25	33	10	62	22	39	5	M130×2	3-M10	60	70	165
B-21A15	530	161	380	285.775	27	6	330.2	330.2	140	6-M22	34	60	98.5	93.2	87.5	21.5	38	15	65	25	39	5	M155×3	3-M12	80	73	180
B-24A15	610	170	380	285.775	27	6	330.2	330.2	165	6-M22	35	60	108	102.7	117.5	21.5	47	24	65	25	40.5	5	M175×3	3-M12	80	73	180

■ 仕様表 Specifications

※把握径/把握範囲は標準のソフトジョーを使用した場合。 ※Gripping dia./gripping range is with standard soft jaws.

仕様 型式 Model	貫通孔径 Thru-Hole mm	把握径 Gripping range mm	ジョーストローク(直径) Jaw Stroke(diameter) mm	プランジャストローク Plunger Stroke mm	許容最大入力 Max. Draw Bar Pull Force kN	最大静的把握力 Max. Gripping Force kN	許容最高回転速度 Max. Speed min ⁻¹	質量(標準ソフトジョー付) Net Weight with Soft top jaws kg	慣性モーメント Moment of Inertia kg·m ²	適合シリンダ Matching Cylinder	許容最大油圧 Max. pressure MPa	適合ハードジョー Matching Hard top jaw	標準ソフトジョー Matching Soft top jaw	主軸端呼び Spindle nose size
B-15A08	117.5	381 30	10.6	23	71	180	2500	134	2.47	F2511H	2.3	HB15A1	SJ15C1	A2- 8
B-15A11	117.5	381 30	10.6	23	71	180	2500	127	2.385	F2511H	2.3	HB15A1	SJ15C1	A2-11
B-18A11	117.5	450 30	10.6	23	71	180	2000	178	4.775	F2511H	2.3	HB15A1	SJ15C1	A2-11
B-21A15	140	530 87	10.6	23	90	234	1700	246	9.25	F2511H	3.0	HB18B2	SJ18A2	A2-15
B-24A15	165	610 109	10.6	23	90	234	1400	304	16.85	F2511H	3.0	HB18B2	SJ18A2	A2-15



CHUCK

高精度中空パワーチャック High Precision Thru-Hole Power Chuck BS300 series

**ジョーの浮き上がり低減
Reduced Jaw Lift
高剛性ボディで安定加工
Stable machining with highly rigid body**



スタンダードチャック
Standard Chuck

- B-200シリーズと取付互換性があります。
Compatible with B-200 series
- モーメント約30%減少を実現
30% drop in bending moment of Master-Jaw
サイドウェッジ機構の採用により浮上りが約30%減少
(当社比/B-200シリーズ比較)
30% Jaw lift reduction by side wedge design.
(Conventional Company Products: B-200 SERIES)

*CE対応品 *CE corresponding

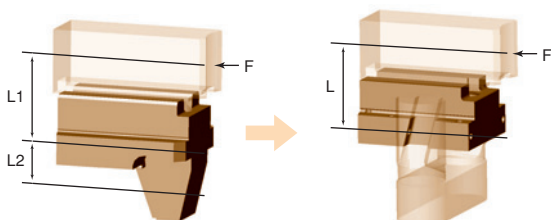

従来のマスタジョー
Existing Master-Jaw

サイドウェッジ機構のマスタジョー
Side Wedge designed Master-Jaw

$$F(L_1 + L_2) : F \times L \cong 1.3 : 1$$

■ 寸法図 Dimensional Drawings

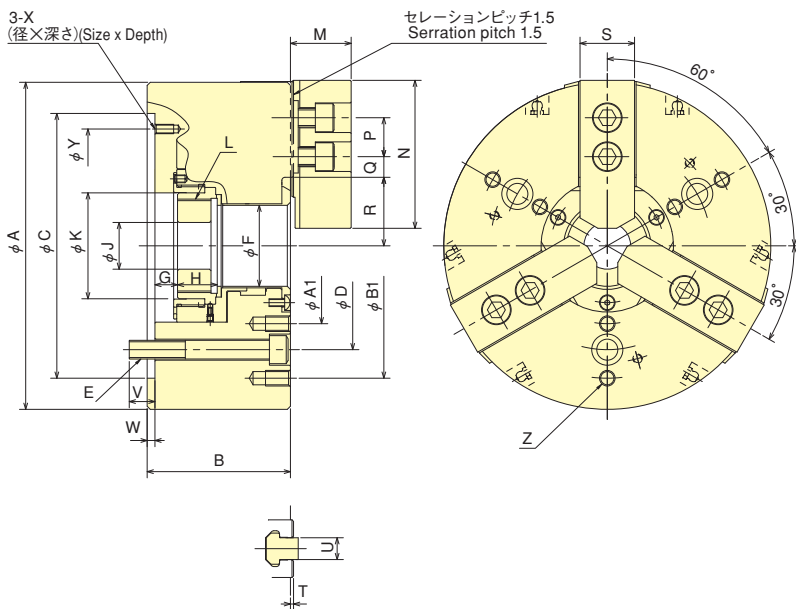

把握力性能曲線 Gripping Characteristic Graphs

*線は標準ソフトジョーを用いた場合のもので。
*With standard blank soft top jaw.

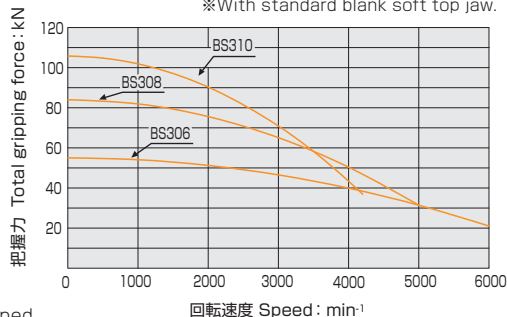

■ 寸法表 Dimensions *ドローナットのねじは未加工です。 *Blank draw nut equipped.

寸法 型式 Model	A	B	C (H6)	D	E	F	G max. min.	H	J	K	L max.	M	N	P	Q max. min. max.	R min.	S	T	U	V	W	X	Y	Z	A1	B1		
BS306	169	85	140	104.8	3-M10	45	11 - 1	20	20	61	M55×2	29	66	20	21.25	9.25	35	32.25	26	2	12	16.5	5	M6×10	116	3×2-M8	77.5	140
BS308	210	92	170	133.4	3-M12	52	14.5 - 0.5	25.5	30	68	M60×2	39	95	25	23.75	11.75	44	40.25	35	2	14	16.5	5	M6×12	150	3×2-M10	100	170
BS310	254	103	220	171.4	3-M16	75	8.5 - 8.5	32.5	45	94	M85×2	43	110	30	30.75	11.25	55	50.45	40	2	16	23.2	5	M8×15	190	3×2-M10	128	216

■ 仕様表 Specifications *把握径/把握範囲は標準のソフトジョーを使用した場合。 *Gripping dia./gripping range is with standard soft jaws.

仕様 型式 Model	貫通穴径 Thru-Hole mm	把握径 Gripping range mm Max. Min.	ジョーストローク(節) Jaw Stroke(diameter) mm	プランジストローク Plunger Stroke mm	許容最大入力 Max. Draw Bar Pull Force kN	最大静的把握力 Max. Gripping Force kN	許容最高回転速度 Max. Speed min⁻¹	質量(標準ソフトジョー) Net Weight with Soft top jaws kg	慣性モーメント Moment of inertia kg·m²	適合シリンダ Matching Cylinder	許容最大油圧力 Max. pressure MPa	適合ハードジョー Matching Hard top jaw	標準ソフトジョー Matching Soft top jaw
BS306	45	169 26	5.5	12	22	55	6000	11.5	0.060	S1246	2.8	HB06B1	SJ06L1A
BS308	52	210 19	7.5	14	34.8	84	5000	22.5	0.125	S1552	2.65	HB08B1	SJ08B1
BS310	75	254 34	9.1	17	43	105.8	4200	34.5	0.325	S1875	2.7	HB10AA1	SJ10B1



CHUCK

高精度中空パワーチャック (ショートテーパ) High Precision Thru-Hole Power Chuck (Direct Mount) BS300A series

スピンドルノーズ対応バックプレート付き
Equipped with Chuck Adaptor to suit Spindle Nose
高剛性ボディで安定加工
Stable machining with highly rigid body

*CE対応品 *CE corresponding

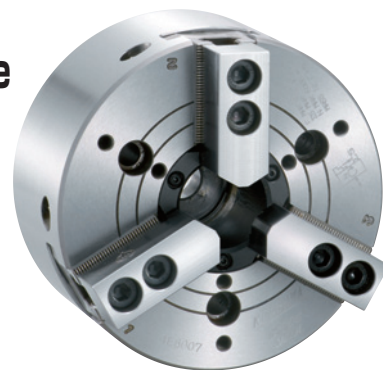

■ 寸法図 Dimensional Drawings

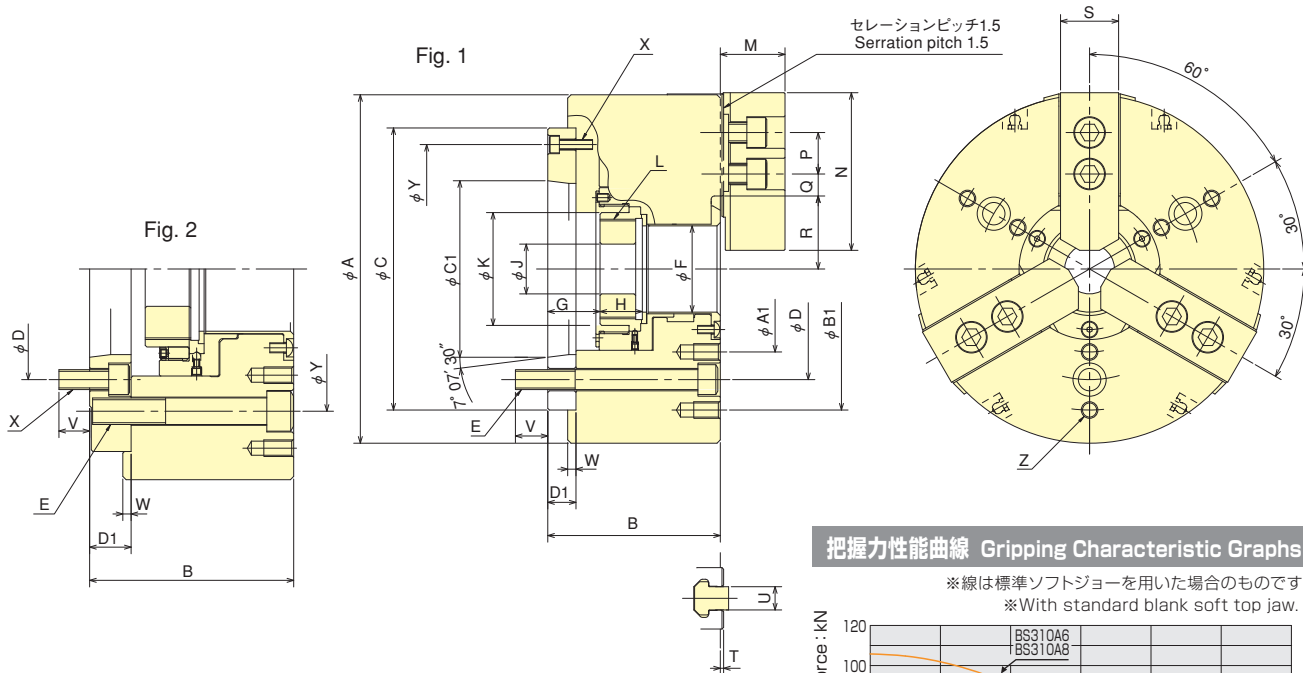

把握力性能曲線 Gripping Characteristic Graphs

※線は標準ソフトジョーを用いた場合のものです。
※With standard blank soft jaw.

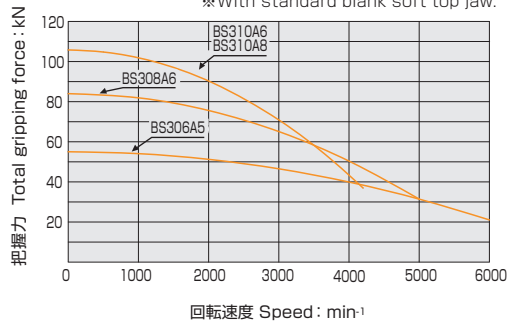

■ 寸法表 Dimensions

※BS310A6はFig.2参照。 ※ドローナットのねじは未加工です。
※BS310A6 is referred to in Fig.2. ※Blank draw nut equipped.

型式 Model	A	B	C	D	E	F	G max.	G min.	H	J	K	L max.	M	N	P	Q max.	Q min.	R max.	R min.	S	T	U	V	W	X	Y	Z	A1	B1	C1	D1
BS306A5	169	95	140	104.8	3M10	45	26	14	20	20	61	M55×2	29	66	20	21.25	9.25	35	32.25	26	2	12	16.5	5	3-M 6	116	3×2-M8	77.5	140	82.563	15
BS308A6	210	104	170	133.4	3M12	52	31.5	17.5	25.5	30	68	M60×2	39	95	25	23.75	11.75	44	40.25	35	2	14	19.5	5	3-M 6	150	3×2-M10	100	170	106.375	17
BS310A6	254	123	220	133.4	3M16	75	33.5	16.5	32.5	45	94	M85×2	43	110	30	30.75	11.25	55	50.45	40	2	16	18.5	5	6-M12	171.4	3×2-M10	128	216	106.375	25
BS310A8	254	116	220	171.4	3M16	75	26.5	9.5	32.5	45	94	M85×2	43	110	30	30.75	11.25	55	50.45	40	2	16	25.2	5	3-M 8	190	3×2-M10	128	216	139.719	18

■ 仕様表 Specifications

※把握径/把握範囲は標準のソフトジョーを使用した場合。 ※Gripping dia./gripping range is with standard soft jaws.

型式 Model	貫通孔径 Thru-Hole mm	把握径 Gripping range mm	ジョーストローク Jaw Stroke(diameter) mm	プランジャストローク Plunger Stroke mm	許容最大入力 Max. Draw Bar Pull Force kN	最大静的把握力 Max. Gripping Force kN	許容最高回転速度 Max. Speed min ⁻¹	質量(標準ソフトジョー付) Net Weight with Soft top jaws kg	慣性モーメント Moment of Inertia kg·m ²	適合シリンダ Matching Cylinder	許容最大油圧 Max. pressure MPa	適合ハードジョー Matching Hard top jaw	標準ソフトジョー Matching Soft top jaw	主軸端呼び Spindle nose size
BS306A5	45	169 26	5.5	12	22	55	6000	12.7	0.063	S1246	2.8	HB06B1	SJ06L1A	A2-5
BS308A6	52	210 19	7.5	14	34.8	84	5000	24.4	0.135	S1552	2.65	HB08A1	SJ08B1	A2-6
BS310A6	75	254 34	9.1	17	43	105.8	4200	40.3	0.368	S1875	2.7	HB10A1	SJ10B1	A2-6
BS310A8	75	254 34	9.1	17	43	105.8	4200	37.8	0.353	S1875	2.7	HB10A1	SJ10B1	A2-8

スタンダードチャック



CHUCK

中空ロングストロークパワーチャック Long Stroke Power Chuck BL-200 series

**3倍のジョーストローク
Extra Long Jaw Stroke
突起物ワークも確実把握
Flange work-pieces securely gripped**

*CE対応品 *CE corresponding



スタンダードチャック
Standard Chuck

■ 寸法図 Dimensional Drawings

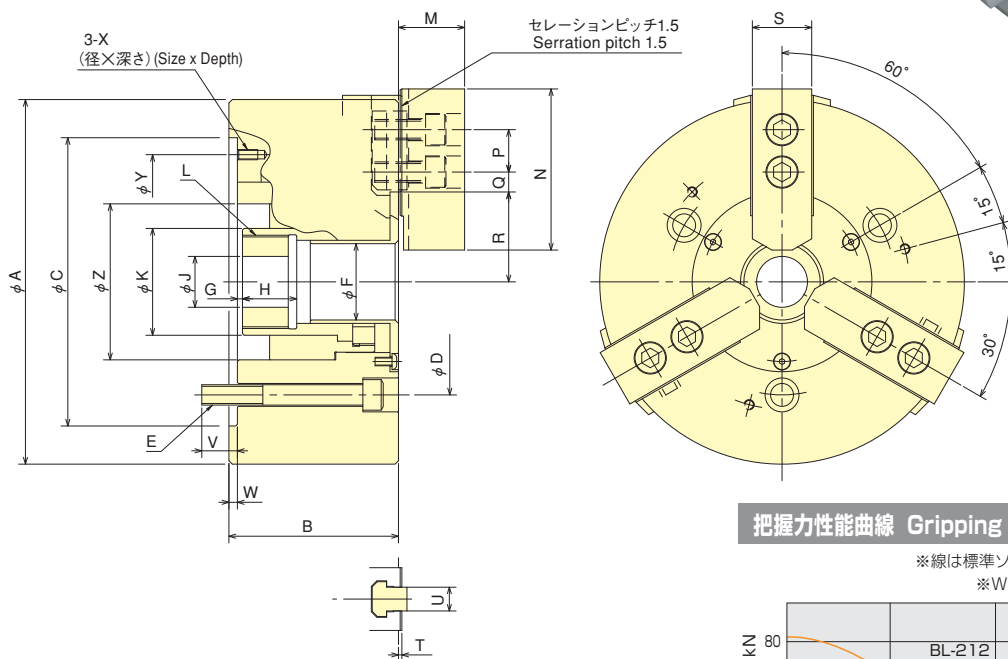

把握性能曲線 Gripping Characteristic Graphs

※線は標準ソフトジョーを用いた場合のものです。
※With standard blank soft top jaw.

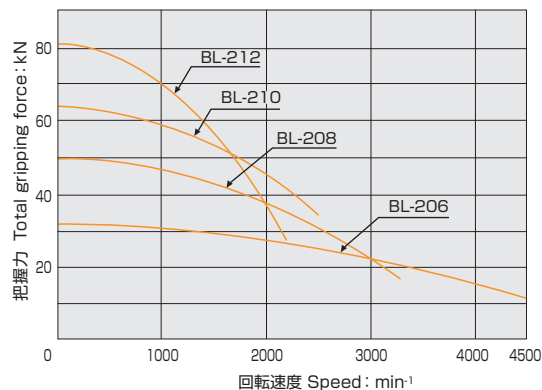

■ 寸法表 Dimensions ※ドローナットのねじは未加工です。 ※Blank draw nut equipped.

型式 Model	A	B	C (H6)	D	E	F	G max.	G min.	H	J	K	L max.	M	N	P	Q max.	Q min.	R max.	R min.	S	T	U	V	W	X (3-)	Y	Z
BL-206	165	87	140	104.8	3-M10	28	10	-5	24	20	45	M38×1.5	29	66	20	16.75	9.25	39.25	29.25	26	2	12	16	5	M6×12	116	70
BL-208	215	100	170	133.4	3-M12	45	3	-16	32	30	63	M55×2	39	95	25	20.75	11.75	53	40.5	35	2	14	21	5	M6×12	150	92
BL-210	254	117	220	171.4	3-M16	53	-6	-28	40	45	73	M65×2	43	110	30	26.25	11.25	62.5	47.5	40	2	16	27	5	M8×16	190	102
BL-212	304	138	220	171.4	3-M16	63	8.2	-16.8	38	50	83	M75×2	52	111	30	38.25	12.75	74.5	57	50	3	21	23	5	M8×16	190	120

■ 仕様表 Specifications ※把握径/把握範囲は標準のソフトジョーを使用した場合。 ※Gripping dia./gripping range is with standard soft jaws.

型式 Model	実通穴径 Thru-Hole mm	把握径 Gripping range mm	ジョーストローク(直径) Jaw Stroke(diameter) mm	プランジャストローク Plunger Stroke mm	許容最大入力 Max. Draw Bar Pull Force kN	最大静的把握力 Max. Gripping Force kN	許容最高回転速度 Max. Speed min⁻¹	質量(標準ソフトジョー付) Net Weight with Soft top jaws kg	慣性モーメント Moment of inertia kg·m²	適合シリンダ Matching Cylinder	許容最大油圧 Max. pressure MPa	適合ハードジョー Matching Hard top jaw	標準ソフトジョー Matching Soft top jaw
BL-206	28	165 24	20	15	27.9	31.2	4500	14	0.043	S1246	3.40	HB06B1	SJ06L1A
BL-208	45	215 26	25	19	41.1	49.0	3300	25	0.198	S1552	2.99	HB08A1	SJ08B1
BL-210	53	254 33	30	22	53.8	63	3000	45	0.306	S1875	3.20	HB10A1	SJ10B1
BL-212	63	304 36	35	25	69.3	80.4	2200	78	0.918	S2091	3.22	HB12N1	SJ12N1



CHUCK

高速中空パワーチャック Counter Balanced Power Chuck HOH series

**カウンターバランス構造
Counter Balance Design
超高速回転でも確実把握
Secure gripping at high speeds**

*CE対応品 *CE corresponding



■ 寸法図 Dimensional Drawings

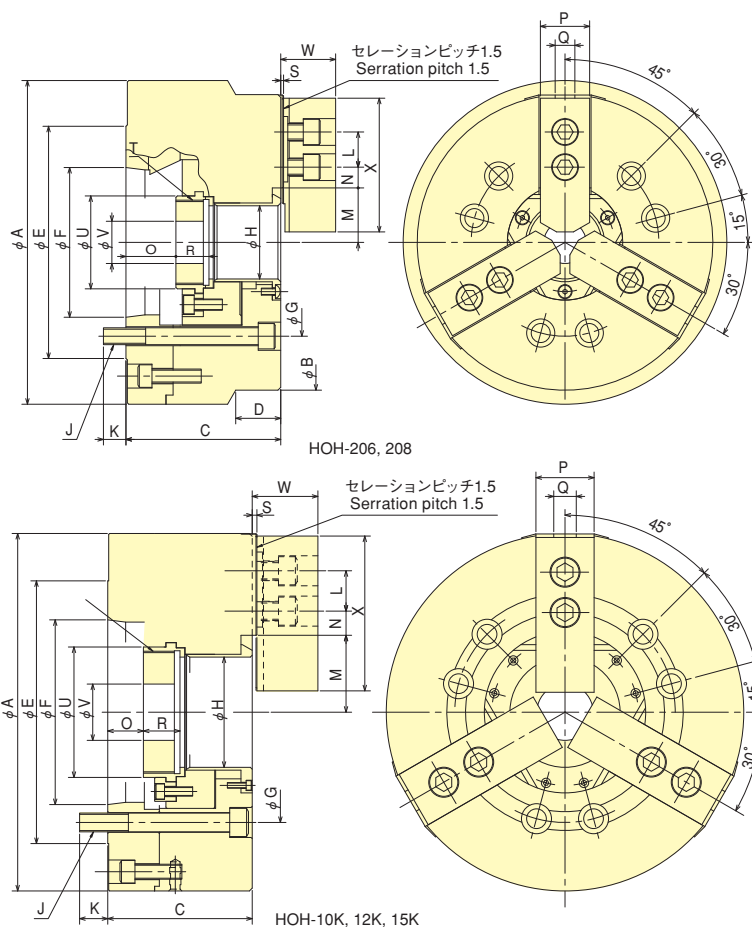

把握力性能曲線 Gripping Characteristic Graphs

※線は標準ソフトジョーを用いた場合のものです。
※With standard blank soft top jaw.

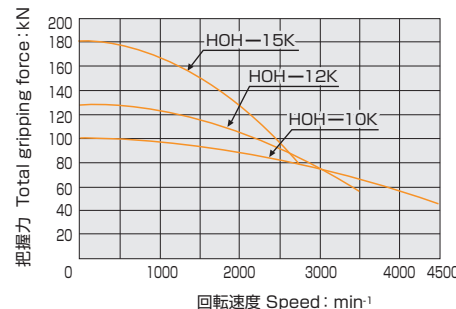
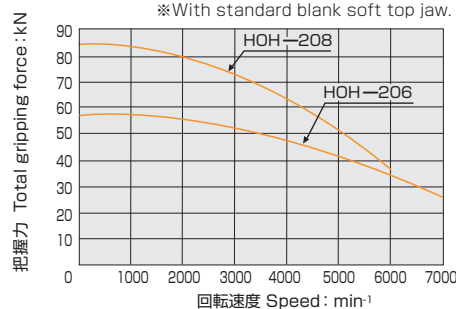

■ 寸法表 Dimensions ※ドローナットのねじは未加工です。 ※Blank draw nut equipped.

型式 Model	A	B	C	D	E	F	G	H	J	K	L	M max.	M min.	N max.	N min.	O max.	O min.	P	Q	R	S	T max.	U	V	W	X
HOH-206	175	169	95	322	135	82.563	104.8	45	6-M10	17	20	32	29.25	22.75	9.25	30	18	26	12	19	2	M55×2	60	20	29	66
HOH-208	230	210	110	32	165	106.375	133.4	52	6-M12	16	25	38.7	35	29.75	14.75	35.5	19.5	35	14	23.5	2	M60×2	66	30	39	95
HOH-10K	254	-	114	-	210	139.719	171.4	65	6-M16	24	30	50	45.6	32.25	12.75	14	-5	40	16	35	5	M75×2	84.5	45	46	110
HOH-12K	304	-	125	-	210	139.719	171.4	78	6-M16	23	30	58	52.7	48.75	14.25	29	6	50	18	38	5	M88×2	96	50	54	129
HOH-15K	381	-	154	-	280	196.869	235	117.5	6-M20	30	43	82	76.7	43.75	18.25	38	15	62	22	39	5	M130×2	139	60	70	165

■ 仕様表 Specifications ※許容最高回転速度は、実測値によります。 ※Max. speed is shown using actual test data.

仕様 Specifications Model	貫通穴径 Thru-Hole mm	把握径 Gripping range mm Max. Min.	ジョーストローク(直径) Jaw Stroke(diameter) mm	プランジャストローク Plunger Stroke mm	許容最大入力 Max. Draw Bar Pull Force kN	最大静的把握力 Max. Gripping Force kN	許容最高回転速度 Max. Speed min ⁻¹	質量(標準ソフトジョー付) Net Weight with Soft top jaws kg	慣性モーメント Moment of inertia kg·m ²	適合シリンダ Matching Cylinder	許容最大油圧 Max. pressure MPa	適合ハードジョー Matching Hard top jaw	標準ソフトジョー Matching Soft top jaw	主軸端呼び Spindle nose size
HOH-206	45	169 16	5.5	12	22	57	7000	15.7	0.068	S1246	2.8	HB06B1	SJ06L1A	A2- 5
HOH-208	52	210 13	7.4	16	34	84	6000	29	0.193	S1552	2.6	HB08A1	SJ08B1	A2- 6
HOH-10K	65	254 25	8.8	19	38	99	4500	40	0.350	S1875	2.3	HB10A1	SJ10B1	A2- 8
HOH-12K	78	304 23	10.6	23	49	129	3500	67	0.875	S2091	2.3	HB12B1	SJ12A1	A2- 8
HOH-15K	117.5	381 30	10.6	23	71	180	2800	124	2.550	F2511H	2.3	HB15A1	SJ15C1	A2-11



CHUCK

2爪高精度大貫通穴径中空パワーチャック

2-Jaw High-Precision, Ultra-large Through-hole Power Chuck

BRT series

特許第6411619号 Pat. No. 6411619
特許第6345321号 Pat. No. 6345321

2爪も次世代の高精度に
Higher precision 2-jaw gripping
把握精度は3爪のBRシリーズと同等の高精度
Gripping accuracy is as good as BR series

*CE対応品 *CE corresponding

2021年度日本機械学会賞(技術)受賞
Received the 2021 JSME Award (Technology)

Next Generation
Standard Chuck **BR**
SERIES



スタンダードチャック

■ 寸法図 Dimensional Drawings

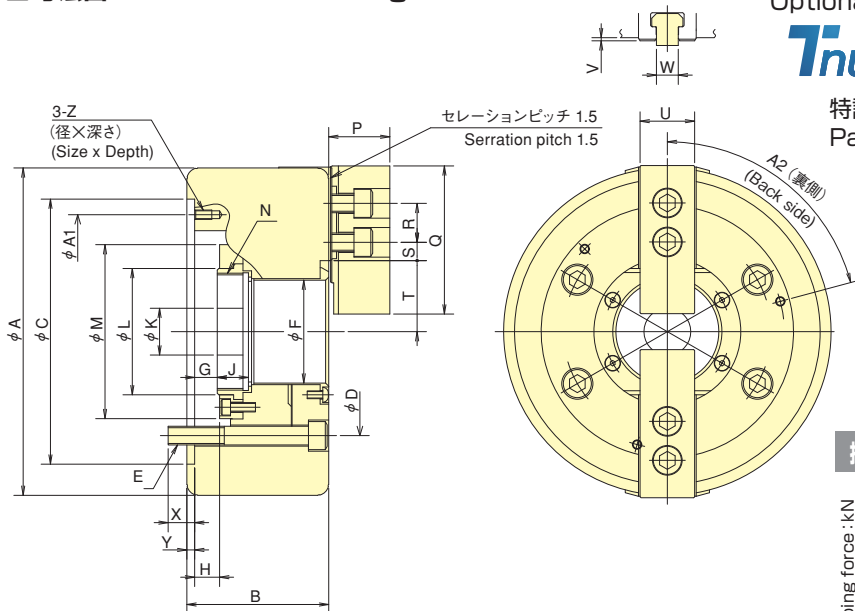

オプションの特殊Tナット
Optional special Nut

Tnut-Plus

特許第6345375号
Pat. No. 6345375



把握力性能曲線 Gripping Characteristic Graphs

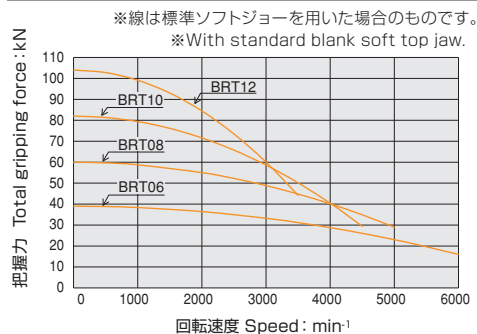

■ 寸法表 Dimensions ※ドローナットのねじは未加工です。 ※Blank draw nut equipped.

型式 Model	A	B	C (H6)	D	E	F	G max.	G min.	H max.	H min.	J	K	L	M	N max.	P	Q	R	S max.	S min.	T max.	T min.	U	V	W	X	Y	Z	A1	A2
BRT06	170	81	140	104.8	4-M10	53	11	-1	12	0	17.5	20	66	89.7	M60×2	33.2	72	20	21.25	9.25	36.05	33.3	31	2	12	16	5	M6×11	116	90°
BRT08	210	91	170	133.4	4-M12	66	14.5	-1.5	16	0	20	30	81	111.6	M75×2	39.2	95	25	24	12	45.5	41.8	35	2	14	17	5	M6×11	150	75°
BRT10	254	100	220	171.4	4-M16	81	8.5	-10.5	19	0	25	45	97	138.7	M90×2	43.2	110	30	32.5	11.5	54	49.6	40	2	16	22	5	M8×15	190	75°
BRT12	315	108	300	235	4-M20	106	8	-15	23	0	28	50	124	166.7	M115×2	52	111	30	45.75	12.75	68.8	63.5	50	2.8	21	29	6	M10×16	260	75°

■ 仕様表 Specifications ※把握径/把握範囲は標準のソフトジョーを使用した場合。 ※Gripping dia./ Gripping range is with standard jaws.

型式 Model	真通穴径 Thru-Hole mm	把握径 Gripping range mm	ジョーストローク(直径) Jaw Stroke(diameter) mm	プラグストローク Plunger Stroke mm	許容最高回転速度 Max. Speed min ⁻¹	許容最大入力 Max. Draw Bar Pull Force kN	最大静的把握力 Max. Gripping Force kN	最高回転時の動的把握力 Dynamic gripping force at max. speed kN	質量 Net Weight kg	慣性モーメント Moment of Inertia kg·m ²	適合シリンダ Matching Cylinder	許容最大油圧力 Max. pressure MPa	標準ソフトジョー Matching Soft top jaw
BRT06	53	170 20	5.5	12	6000	15.3	39	16	12.5	0.05	SR1453 SS1453K	1.6 1.5	SJ06A1T
BRT08	66	210 28	7.4	16	5000	23.3	60	29	21.7	0.13	SR1566 SS1666K	2.2 1.8	SJ08A1
BRT10	81	254 38	8.8	19	4500	32.7	82	29.4	34.9	0.32	SR1781 SS1881K	2.3 2.2	SJ10A1
BRT12	106	315 54	10.6	23	3500	40	104	44.2	56.2	0.78	SS2110K	2.1	SJ12N1

※質量・慣性モーメントは取付ボルト、ソフトジョーを含んだもので、マスタージョー位置はストローク中央、ソフトジョー位置は外形図に記載の取り付け位置として計算しています。
※The weight and the moment of inertia include mounting bolts and soft jaws.
The calculation is assuming that the master jaws are at the centre of stroke and soft jaws are at as of the outline drawing.



CHUCK

2爪中空パワーチャック 2 Jaw Thru-Hole Power Chuck BT200 series

異形加工物の把握に最適 For gripping Irregular shaped components

*CE対応品 *CE corresponding



把握状態例 Gripping Examples

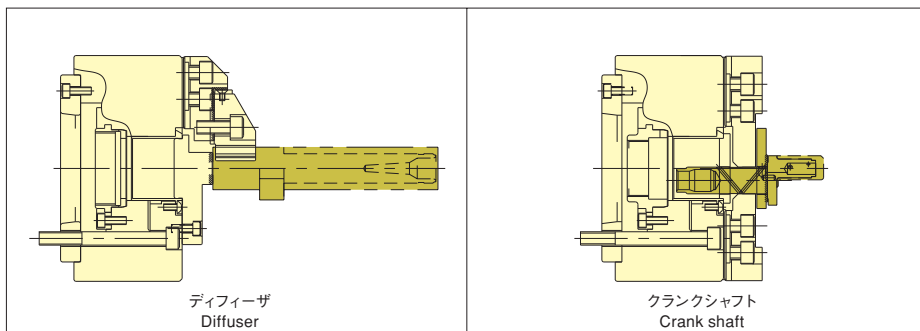

■ 寸法図 Dimensional Drawings

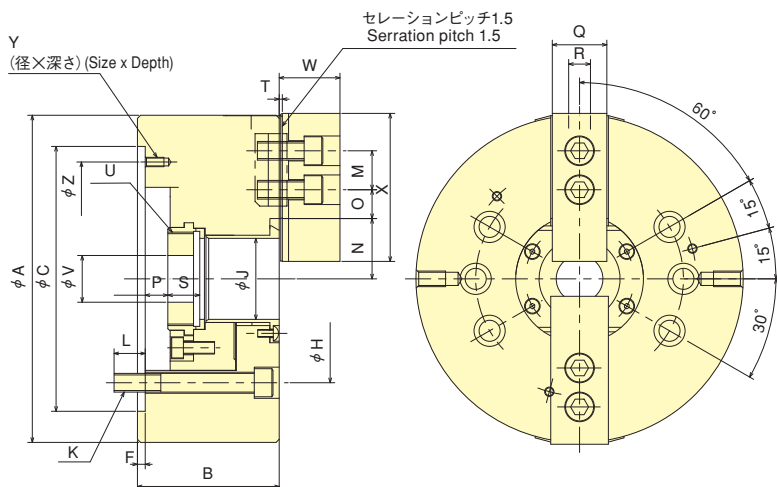

把握力性能曲線 Gripping Characteristic Graphs

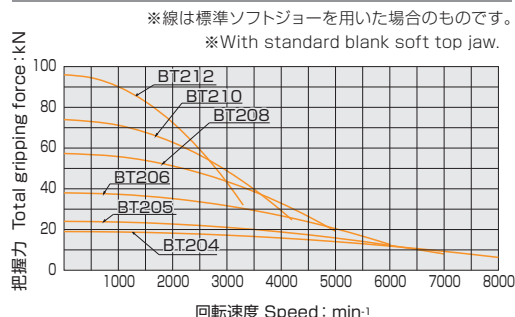

■ 寸法表 Dimensions

*BT204, 205の取付、ジョーセンターより左右60° - 4本 *ドローナットのねじは未加工です。
*Mounting bolt P. C. D. for BT204 & BT205 : each 60° from jaw centre : 4 pcs. *Blank draw nut equipped.

寸法 Model	A	B	C (H6)	F	H	J	K	L	M	N max.	N min.	O max.	O min.	P max.	P min.	Q	R	S	T	U max.	V	W	X	Y	Z
BT204	110	59	85	4	706	26	4-M10	15.5	14	23	20.3	11.25	6.75	3.5	- 65	23	10	17.5	2	M32x1.5	12	24	49.5	-	-
BT205	135	60	110	4	825.5	33	4-M10	15	14	26.5	23.8	19.75	7.75	1	- 9	23	10	20	2	M40x1.5	12	26	54	-	-
BT206	169	81	140	5	1048	45	6-M10	16	20	32	29.25	22.75	9.25	11	- 1	26	12	19	2	M55x2	20	29	66	4-M6x10	116
BT208	210	91	170	5	1334	52	6-M12	20	25	38.7	35	30	15	14.5	- 1.5	35	14	20.5	2	M60x2	30	39	95	3-M6x12	150
BT210	254	100	220	5	1714	75	6-M16	22	30	51	46.6	34	14.5	8.5	- 10.5	40	16	25	2	M85x2	45	43	110	3-M8x15	190
BT212	304	110	220	6	1714	91	6-M16	23	30	61.3	56	45.75	15.75	8	- 15	50	21	28	2	M100x2	50	51	111	3-M8x15	190

■ 仕様表 Specifications

*許容最高回転速度は、実測値によります。 *Max. speed is shown using actual test data.
*把握径/把握範囲は標準のソフトジョーを使用した場合。 *Gripping dia./gripping range is with standard soft jaws.

仕様 Model	貫通穴径 Thru-Hole mm	把握径 Gripping range mm	ジョーストローク (直径) Jaw Stroke (diameter) mm	プランジャストローク Plunger Stroke mm	許容最大入力 Max. Draw Bar Pull Force kN	最大静的把握力 Max. Gripping Force kN	許容最高回転速度 Max. Speed min ⁻¹	質量 (標準ソフトジョー付) Net Weight with Soft top jaws kg	慣性モーメント Moment of inertia kg·m ²	適合シリンダ Matching Cylinder	許容最大油圧 Max. pressure MPa	標準ソフトジョー Matching Soft top jaw
BT204	26	110 9	5.4	10	9.3	19	8000	3.8	0.006	F0933H	1.94	SJ04N1T
BT205	33	135 14	5.4	10	11.7	24	7000	6.5	0.017	F0933H	2.38	SJ05N1T
BT206	45	169 17	5.5	12	14.5	38	6000	11.5	0.056	S1246	1.85	SJ06L1T
BT208	52	210 17	7.4	16	23.2	57.3	5000	21.3	0.165	S1552	1.80	SJ08A1
BT210	75	254 38	8.8	19	28.5	74	4200	33.5	0.308	S1875	1.80	SJ10A1
BT212	91	304 41	10.6	23	36.7	96	3300	52	0.700	S2091	1.81	SJ12N1

*3爪から2爪への変更は、バックプレートを交換する事で取付可能です。
*Altering Back Plate enables to change over 3-Jaw Chuck into 2-Jaw Chuck.



CHUCK

2爪中空ロングストロークパワーチャック 2-Jaw Long Stroke Power Chuck BLT200 series

異形加工物の把握に最適

Extra Long Jaw Stroke for gripping Irregular shaped components

突起物ワークも確実把握

Flange work-pieces securely gripped

*CE対応品 *CE corresponding



スタンダードチャック
Standard Chuck

把握状態例 Gripping Examples

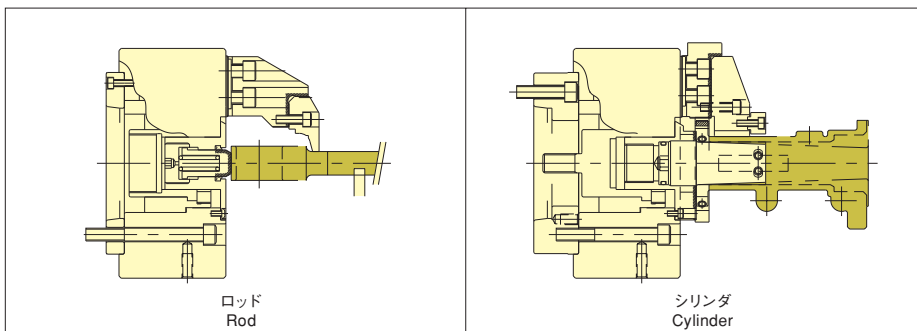

■ 寸法図 Dimensional Drawings

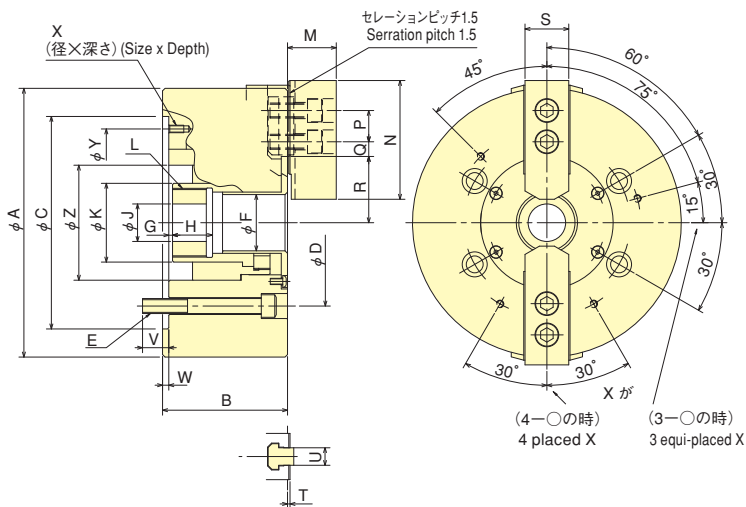

把握力性能曲線 Gripping Characteristic Graphs

※線は標準ソフトジョーを用いた場合のもので、
※With standard blank soft top jaw.

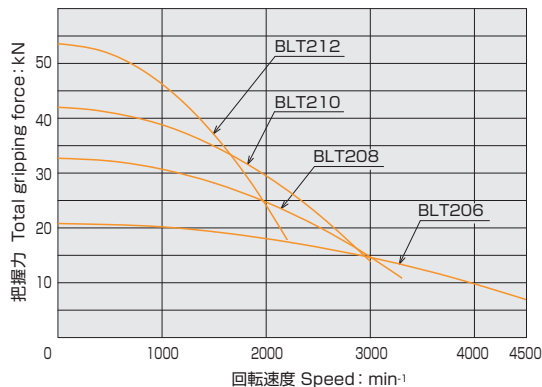

■ 寸法表 Dimensions ※ドローナットのねじは未加工です。 ※Blank draw nut equipped.

寸法 型式 Model	A	B	C (H6)	D	E	F	G max.	G min.	H	J	K	L max.	M	N	P	Q max.	Q min.	R max.	R min.	S	T	U	V	W	X	Y	Z
BLT206	165	87	140	104.8	4-M10	28	10	-5	24	20	45	M38×1.5	29	66	20	16.75	9.25	39.25	29.25	26	2	12	16	5	4-M6×12	116	70
BLT208	215	100	170	133.4	4-M12	45	3	-16	32	30	63	M55×2	39	95	25	21	12	53	40.5	35	2	14	21	5	3-M6×12	150	92
BLT210	254	117	220	171.4	4-M16	53	-6	-28	40	45	73	M65×2	43	110	30	26.5	11.5	62.5	47.5	40	2	16	27	5	3-M8×16	190	102
BLT212	304	138	220	171.4	4-M16	63	8.2	-16.8	38	50	83	M75×2	52	111	30	38.25	12.75	74.5	57	50	3	21	23	5	3-M8×16	190	120

■ 仕様表 Specifications ※把握径/把握範囲は標準のソフトジョーを使用した場合。 ※Gripping dia./gripping range is with standard soft jaws.

仕様 型式 Model	貫通穴径 Thru-Hole mm	把握径 Gripping range mm Max. Min.	ジョーストローク (値) Jaw Stroke (diameter) mm	プランジャストローク Plunger Stroke mm	許容最大入力 Max. Draw Bar Pull Force kN	最大静的把握力 Max. Gripping Force kN	許容最高回転速度 Max. Speed min ⁻¹	質量 (標準ソフトジョー付) Net Weight with soft top jaws kg	慣性モーメント Moment of Inertia kg·m ²	適合シリンダ Matching Cylinder	許容最大油圧力 Max. pressure MPa	標準ソフトジョー Matching Soft top jaw
BLT206	28	165 24	20	15	18.6	20.8	4500	13.5	0.042	S1246	2.36	SJ06L1T
BLT208	45	215 32	25	19	27.4	32.7	3300	24	0.193	S1552	2.08	SJ08A1
BLT210	53	254 40	30	22	35.9	42	3000	43.5	0.290	S1875	2.20	SJ10A1
BLT212	63	304 44	35	25	46.2	53.6	2200	75.5	0.903	S2091	2.22	SJ12N1

※3爪から2爪への変更は、バックプレートを交換する事で取付可能です。

※Altering Back Plate enables to change over 3-Jaw Chuck into 2-Jaw Chuck.



CHUCK

クイックジョーチェンジチャック Quick Jaw-Change Chuck QB300 series

ジョー一段取りが容易 Quick Jaw Replacement

多品種少量の加工に最適

Suitable for small and large batch production of Top Jaw



*CE対応品 *CE corresponding

QB300NがCE対応品になります。

ジョー交換用ハンドル以外はQB300と同じになります。

CE Correspondence (QB300N)

The specification is the same as that of QB300 chuck except jaw release handle.

■ 寸法図 Dimensional Drawings

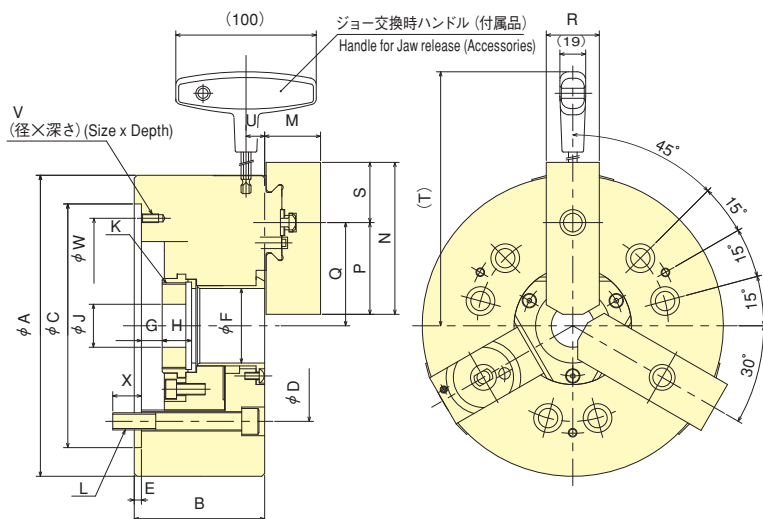

把握力性能曲線 Gripping Characteristic Graphs

※線は標準ソフトジョーを用いた場合のものです。
※With standard blank soft top jaw.

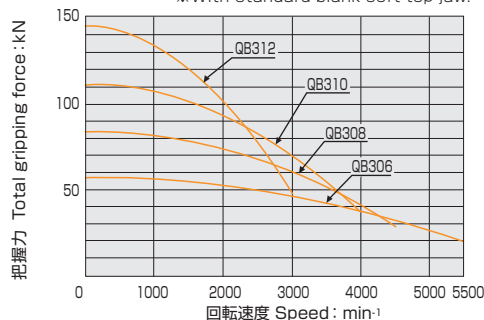

注) 鋳・鍛造品の素材加工については御相談下さい。
Note) Please contact our engineering regarding casting and forgin material machining.

■ 寸法表 Dimensions ※ドローナットのねじは未加工です。 ※Blank draw nut equipped.

寸法 Dimensions Model	A	B	C (H _B)	D	E	F	G max.	G min.	H	J	K max.	L	M	N	P	Q max.	Q min.	R	S	T	U	V	W	X
QB306	169	81	140	104.8	5	45	11	-1	19	20	M55×2	6-M10	31	90	54	58.5	55.75	32	36	192.5	13	M6×10	116	16
QB308	210	91	170	133.4	5	52	14.5	-1.5	20.5	30	M60×2	6-M12	39	106	64	72	68.3	37	42	220.7	13	M6×12	150	20
QB310	254	100	220	171.4	5	75	8.5	-10.5	25	45	M85×2	6-M16	43	125	76	88	83.6	42	49	242	15.5	M8×15	190	22
QB312	304	110	220	171.4	6	91	8	-15	28	50	M100×2	6-M16	51	139	90	106.3	101	42	49	267	15.5	M8×15	190	23

■ 仕様表 Specifications

※許容最高回転速度は、実測値によります。 ※Max. speed is shown using actual test data.

※把握径/把握範囲は標準のソフトジョーを使用した場合。 ※Gripping dia./gripping range is with standard soft jaws.

仕様 Specifications Model	貫通穴径 Thru-Hole mm	把握径 Gripping range mm Max. Min.	ジョーストローク (直径) Jaw Stroke (diameter) mm	プランジャストローク Plunger Stroke mm	許容最大入力 Max. Draw Bar Pull Force kN	最大静的把握力 Max. Gripping Force kN	許容最高回転速度 Max. Speed min ⁻¹	質量 (標準ソフトジョー付) Net Weight with Soft top jaws kg	慣性モーメント Moment of inertia kg·m ²	適合シリンダ Matching Cylinder	許容最大油圧 Max. pressure MPa	標準ソフトジョー Matching Soft top jaw
QB306	45	140 8	5.5	12	22	57	5500	12.6	0.058	S1246	2.8	SB06BB
QB308	52	180 15	7.4	16	34	84	4500	23.2	0.173	S1552	2.6	SB08BB
QB310	75	210 23	8.8	19	43	111	4000	35	0.318	S1875	2.7	SB10BB
QB312	91	250 32	10.6	23	55	144	3000	56	0.745	S2091	2.7	SB12BB

■ ソフトジョー寸法図 Soft Top Jaw Dimensional Drawings

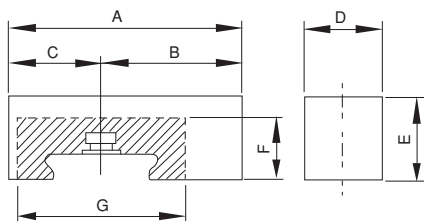

注)ハッチング部分は成形禁止域を示します。
Note)No modification is allowed in shaded area.

■ ソフトジョー寸法表 Dimensions for Soft Top Jaw

ソフトジョー型式寸法 Soft Jaw Model Dimensions	6"		8"		10"		12"	
	SB06BB	SB06BB-040	SB08BB	SB08BB-056	SB10BB	SB10BB-060	SB12BB	SB12BB-070
A	90	90	106	106	125	125	139	139
B	54	54	64	64	76	76	90	90
C	36	36	42	42	49	49	49	49
D	32	32	37	37	42	42	42	42
E	30	40	38	56	42	60	50	70
F	24	24	28	28	31	31	34	34
G	68	68	76	76	88	88	92	92
最小把握径 Min. gripper range	10	10	18	18	22	22	30	30



CHUCK

クイックジョーチェンジチャック Quick Jaw Replacement Chuck QJR series

変種変量生産対応

Suitable for small and large batch production

クイック&スムーズに簡単ジョー交換

Quick & smooth Jaw Replacement

●スピーディーなジョー交換 Quick Jaw Replacement

ハンドルーつで素早くそしてスムーズにジョー交換が出来ます。
ジョーを交換しても高精度を保つ、高性能なチャックです。

Jaw can be replaced quickly and easily by handle supplied.

●変種変量生産に最適 Suitable for small and large batch production

ジョー交換が簡単なため、変種変量生産の段取り替えが短時間で出来ます。

Resuced set up time by Quick and Easy Jaw Replacement.

●今お使いのチャックと取付互換性あり Interchangeable mounting dimensions

今お使いのKITAGAWA B-200/BB200シリーズと取付互換性がありチャックの交換、取付も簡単です。クラス最大の貫通穴径で、使い勝手の良いチャックです。

Kitagawa's B-200 and BB200 series can be easily replaced with QJR large thru-hole power chucks.

●ベースジョーおよびソフトジョーは、オプションとなります。

Base jaws and Soft jaws are available as option.

*CE対応品 *CE corresponding



スタンダードチャック

■寸法図 Dimensional Drawings

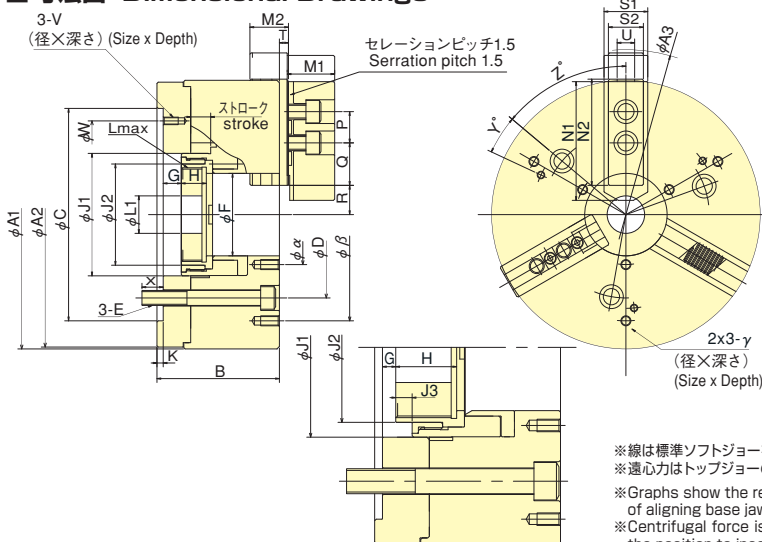

把握力性能曲線 Gripping Characteristic Graphs

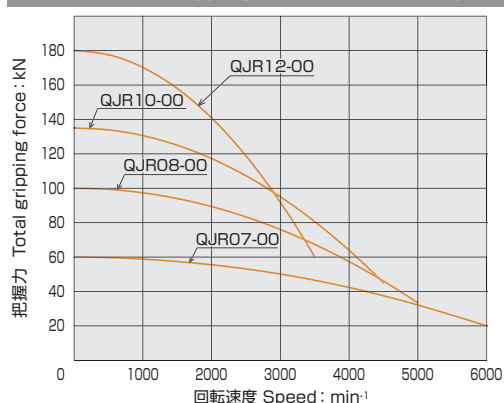

※線は標準ソフトジョーを用い、ベースジョーとチャック外周がほぼ揃った位置での回転速度と把握力の関係です。
※遠心力はトップジョーの大きさや形状や取り付けの向き、ベースジョーの挿入位置により大きく異なります。

※Graphs show the relationship between the rotation speed and the gripping force at the position of aligning base jaws with chuck OD when using standard soft jaws.

※Centrifugal force is different vastly depending on the size, shape or orientation of top jaws, or the position to insert base jaws.

■寸法表 Dimensions

※ドローナットのねじは未加工です。 ※Blank draw nut equipped.

型式 Model	A1	A2	A3	B	C (H6)	D	E	F	G max.	G min.	H	J1	J2	J3	K	L max.	L1	M1	M2
QJR07-00	178	178	212	92	140	104.8	M10	53	11	-4	24	81	66	9.5	5	M60x2	20	32	25.5
QJR08-00	215	212	264	98	170	133.4	M12	66	14.5	-1.5	20	98	81	-	5	M75x2	30	38	30.8
QJR10-00	254	251	312	119	220	171.4	M16	81	8.5	-10.5	39	115	96	10.5	5	M90x2	45	42	39
QJR12-00	315	312	360	133	220(300)	171.4(235)	M16(M20)	106	8	-15	42	140	121	15	6	M115x2	50	50	45.2

型式 Model	N1	N2	P	Q	R max.	R min.	S1	S2	T	U	V	W	X	Y	Z	α	β	γ
QJR07-00	72	73	20	28.5	14-32	10.3-28.3	31	25.5	5.45	12	M6x12	116	17	-30	50	75	155	M8x13
QJR08-00	95	85	25	34	20.4-44.4	16.7-40.7	35	28	7.25	14	M6x12	150	17	15	50	80	170	M8x15
QJR10-00	110	100.5	30	40.5	21.2-52.7	16.8-48.3	40	35	11.3	16	M8x15	190	23	-15	50	100	220	M8x15
QJR12-00	111	108	30	57	33.9-69.9	28.6-64.6	50	50	12	21	M8x15(M10x16)	190(260)	22(27)	-15	45(50)	130	280	M10x17

BB212互換タイプのQJR12-00は、()寸法となります。詳細はお問い合わせ下さい。
The numbers in () are the dimension of QJR12-00 for interchangeable BB212. Please contact us for more details.

■仕様表 Specifications

※把握径/把握範囲は標準のソフトジョーを使用した場合。 ※Gripping dia./gripping range is with standard soft jaws.

型式 Model	貫通穴径 Thru-Hole mm	把握径 Gripping range mm	ジョーストローク(直径) Jaw Stroke(diameter) mm	プランジャストローク Plunger Stroke mm	許容最大入力 Max. Draw Bar Pull Force kN	最大静的把握力 Max. Gripping Force kN	許容最高回転速度 Max. Speed min ⁻¹	質量(標準ソフトジョー付) Net Weight with Soft top jaws kg	慣性モーメント Moment of inertia kg·m ²	※オプション Option	
		Max. Min.								標準ベースジョー Matching Base jaw	標準ソフトジョー Matching Soft top jaw
QJR07-00	53	178 9	7.4	15	25	60	6000	14	0.06	QJR07-BJ00	SJ06B1
QJR08-00	66	210 16	7.4	16	45	100	5000	25	0.18	QJR08-BJ00	SJ08B1
QJR10-00	81	254 22	8.8	19	60	135	4500	45	0.41	QJR10-BJ00	SJ10B1
QJR12-00	106	315 18	10.6	23	81	180	3500	75	1.15	QJR12-BJ00	SJ12N1

※上記型式はベースジョーおよびソフトジョーを含みません。ベースジョーおよびソフトジョーは上記の該当型式で必要数をご注文下さい。
The models above are not included Base jaws or Soft jaws. Please refer above list when ordering Base jaws and soft jaws.



CHUCK

中実パワーチャック Closed Centre Power Chuck

N series

中実のスタンダードチャック The standard Closed Centre chuck

*CE対応品 *CE corresponding



■ 寸法図 Dimensional Drawings

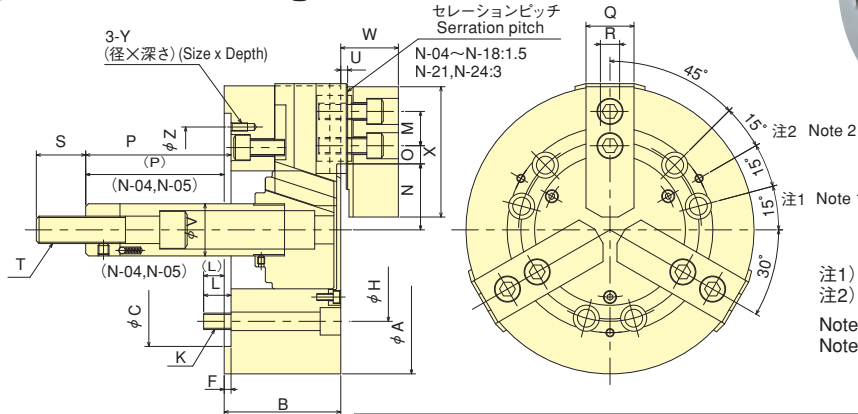

注1) N-21, 24の場合: 0°
注2) N-21, 24の場合: 60°
Note 1) N-21, 24 : 0°
Note 2) N-21, 24 : 60°

把握力性能曲線 Gripping Characteristic Graphs

※線は標準ソフトジョーを用いた場合のものです。 ※With standard blank soft top jaw.

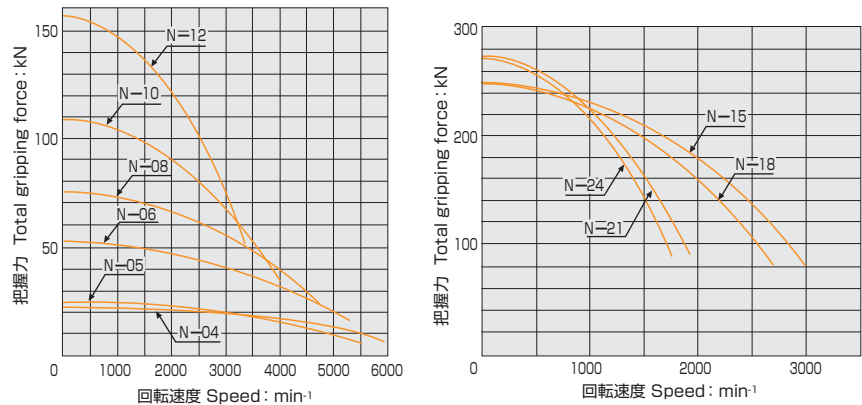

■ 寸法表 Dimensions

※N-04, 05の取付 120.ピッチー3本 ※N-21, 24の取付 60.ピッチー6本
※Mounting bolt P. C. D. for N-04 & N-05 : 120° pitch : 3 pcs. ※Mounting bolt P. C. D. for N-21 & N-24 : 60° pitch : 6 pcs.

型式 Model	A	B	C (H6)	F	H	K	L	M	N max.	N min.	O max.	O min.	P max.	P min.	Q	R	S	T	U	V	W	X	Y	Z
N-04	110	52	60	6	80	3-M8	12	14	233	20.1	11.25	8.25	18	3	23	10	25	M10	3	26	27	55	-	-
N-05	135	55	80	7	100	3-M8	14	19	30.4	27.2	11.25	6.75	9	-6	23	10	35	M12	3	28	29	62	-	-
N-06	165	74	140	5	104.8	6-M10	14	20	37.8	33.55	13.75	7.75	101.5	81.5	31	12	36	M16	4	34	35	72	M6×10	116
N-08	210	85	170	5	133.4	6-M12	20	25	46.3	41.9	22.25	11.75	127	106	35	14	36	M20	5	38	42	95	M6×12	150
N-10	254	89	220	5	171.4	6-M16	18	30	51.1	46.7	30.75	11.25	158	133	40	16	36	M20	5	45	46	110	M8×15	190
N-12	304	106	220	6	171.4	6-M16	18	30	61	55.75	48.75	12.75	163	133	50	18	36	M20	5	50	54	129	M8×15	190
N-15	381	114	300	6	235	6-M20	30	43	77.5	69.5	48.75	23.25	104	69	50	25.5	55	M30	2	60	61	135	M10×20	260
N-18	450	114	300	6	235	6-M20	30	43	108	100	48.75	23.25	92	57	50	25.5	55	M30	2	60	61	135	M10×20	260
N-21	530	125	380	6	330.2	6-M22	31	60	86	78	93.5	27.5	97	62	65	25	55	M30	3	60	71	180	M12×30	330.2
N-24	610	125	380	6	330.2	6-M22	31	60	125	117	93.5	27.5	97	62	65	25	55	M30	3	60	71	180	M12×30	330.2

※許容最高回転速度は、実測値によります ※N-24より大型については問い合わせ下さい。

※Max. speed is shown using actual test data. ※For large type more than N-24, confer with KITAGAWA.

■ 仕様表 Specifications

※把握径/把握範囲は標準のソフトジョーを使用した場合。 ※Gripping dia./gripping range is with standard soft jaws.

仕様 Model	把握径 Gripping range mm		ジョーストローク(直径) Jaw Stroke(diameter) mm	プランジャストローク Plunger Stroke mm	許容最大入力 Max. Draw Bar Pull Force kN	最大静的把握力 Max. Gripping Force kN	許容最高回転速度 Max. Speed min⁻¹	質量(標準ソフトジョー付) Net Weight with Soft top jaw kg	慣性モーメント Moment of inertia kg·m²	適合シリンダ Matching Cylinder		許容最大油圧 Max. pressure MPa	適合ハードジョー Matching Hard top jaw		標準ソフトジョー Matching Soft top jaw
	Max.	Min.								油圧 pressure	エア air		Matching Hard top jaw	Matching Soft top jaw	
N-04	110	6	6.4	15	8.2	22.8	6000	4.1	0.008	Y0715R/PE01C	AY1315R	2.4	HB04N1	SJ04B1	
N-05	135	16	6.4	15	8.2	25.2	5500	6.2	0.015	Y0715R/PE01C	AY1315R	2.4	HB05C1	SJ05B1	
N-06	165	15	8.5	20	18	52.5	5270	13	0.045	Y1020R/PE47	AY1720R	2.6	HB06B1	SJ06B1	
N-08	210	23	8.8	21	25	75	4760	25	0.138	Y1225R/PE47	AY2225R	2.5	HB08A1	SJ08B1	
N-10	254	24	8.8	25	29	108	4010	37	0.300	Y1225R/PE47	AY2225R	2.8	HB10A1	SJ10B1	
N-12	304	26	10.5	30	41	156	3380	57.3	0.725	Y1530R/PE47	-	2.7	HB12B1	SJ12A1	
N-15	381	72	16	35	82	249	3040	101	1.9	Y2035R/PE47	-	3.2	HB15N1	SJ15N1	
N-18	450	133	16	35	82	249	2710	126	3.3	Y2035R/PE47	-	3.2	HB15N1	SJ15N1	
N-21	530	69	16	35	82	273	1940	198	7.1	Y2035R/PE47	-	3.2	HB18B2	SJ18A2	
N-24	610	152	16	35	82	273	1760	252	12.0	Y2035R/PE47	-	3.2	HB18B2	SJ18A2	



CHUCK

中実パワーチャック (ショートテーパ) Closed Centre Power Chuck (Direct Mount) N-A series

スピンドルノーズ対応バックプレート付き Chuck Adaptor is equipped to suit Spindle Nose 中実のスタンダードチャック Closed Centre standard chuck

*CE対応品 *CE corresponding

■ 寸法図 Dimensional Drawings

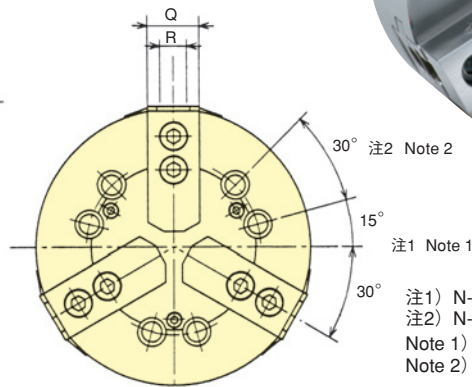
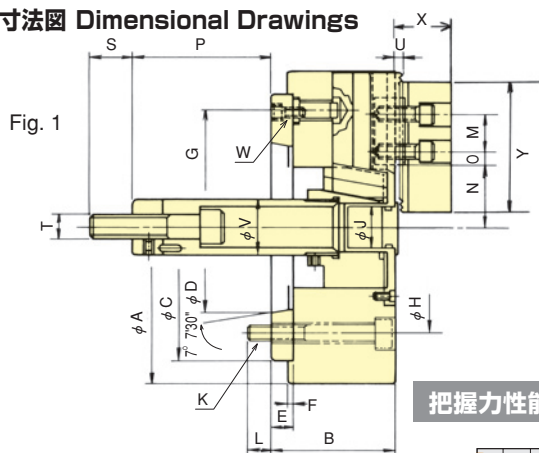

スタンダードチャック Standard Chuck

Fig. 2

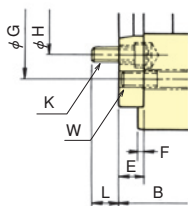

把握力性能曲線 Gripping Characteristic Graphs

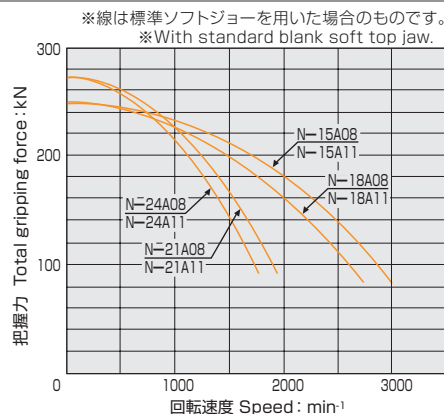
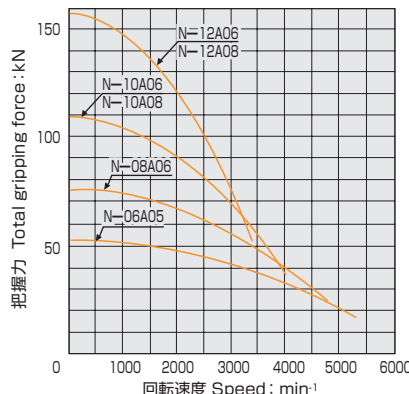

*線は標準ソフトジョーを用いた場合のもので、
*With standard blank soft top jaw.

■ 寸法表 Dimensions

*N-10A06, N-12A06, N-15A08, N-18A08, N-21A08, N-21A11, N-24A11はFig-2による *N-21A08~N-24A15の取付 60°ピッチ=6本
*N-10A06, N-12A06, N-15A08, N-18A08, N-21A08, N-21A11, N-24A11 are referred to in Fig-2 *Mounting Bolt P.C.D for N-21A08~N-24A15: 60° Pitch: 6pcs..

寸法 Model	A	B	C	D	E	F	G	H	J	K	L	M	N max.	N min.	O max.	O min.	P max.	P min.	Q	R	S	T	U	V	W	X	Y
N-06A05	165	84	140	82.563	15	5	116	104.8	21	6M10	14	20	37.8	33.55	13.75	7.75	86.5	66.5	31	12	36	M16	4	34	3-M6	35	72
N-08A06	210	97	170	106.375	17	5	150	133.4	25	6M12	18	25	46.3	41.9	22.25	11.75	110	89	35	14	36	M20	5	38	3-M6	42	96
N-10A06	254	104	220	139.719	20	5	171.4	133.4	34	6M12	18	30	51.1	46.7	30.75	11.25	114	89	40	16	36	M20	5	45	6-M16	46	110
N-10A08	254	102	220	139.719	18	5	190	171.4	34	6M16	25	30	51.1	46.7	30.75	11.25	140	115	40	16	36	M20	5	45	3-M8	46	110
N-12A06	304	120	220	139.719	20	6	171.4	133.4	34	6M12	18	30	61	55.75	48.75	12.75	119	89	50	18	36	M20	5	50	6-M16	54	129
N-12A08	304	118	220	139.719	18	6	190	171.4	34	6M16	25	30	61	55.75	48.75	12.75	145	115	50	18	36	M20	5	50	3-M8	54	129
N-15A08	381	130	300	196.869	22	6	235	171.4	-	6M16	23	43	77.5	69.5	48.75	23.25	82	47	50	25.5	55	M30	2	60	6-M20	61	135
N-15A11	381	130	300	196.869	22	6	260	235	-	6M20	33	43	77.5	69.5	48.75	23.25	82	47	50	25.5	55	M30	2	60	3-M10	61	135
N-18A08	450	130	300	196.869	22	6	235	171.4	-	6M16	23	43	108	100	48.75	23.25	70	35	50	25.5	55	M30	2	60	6-M20	61	135
N-18A11	450	130	300	196.869	22	6	260	235	-	6M20	33	43	108	100	48.75	23.25	70	35	50	25.5	55	M30	2	60	3-M10	61	135
N-21A08	530	146	380	196.869	27	6	330.2	171.4	-	6M16	23	60	86	78	93.5	27.5	70	35	65	25	55	M30	3	60	6-M22	71	180
N-21A11	530	146	380	196.869	27	6	330.2	235	-	6M20	28	60	86	78	93.5	27.5	70	35	65	25	55	M30	3	60	6-M22	71	180
N-21A15	530	146	380	285.775	27	6	330.2	330.2	-	6M22	34	60	86	78	93.5	27.5	70	35	65	25	55	M30	3	60	3-M12	71	180
N-24A11	610	146	380	196.869	27	6	330.2	235	-	6M20	28	60	125	117	93.5	27.5	70	35	65	25	55	M30	3	60	6-M22	71	180
N-24A15	610	146	380	285.775	27	6	330.2	330.2	-	6M22	34	60	125	117	93.5	27.5	70	35	65	25	55	M30	3	60	3-M12	71	180

■ 仕様表 Specifications

*許容最高回転速度は、実測値によります。 *Max. speed is shown using actual test data.
*把握径/把握範囲は標準のソフトジョーを使用した場合。 *Gripping dia./gripping range is with standard soft jaws.

仕様 Model	把握径 Gripping range		スロークロウ Jaw Stroke (mm)	プランジャーストローク Plunger Stroke (mm)	許容最大入力 Max. Input Force (kN)	最大静的把握力 Max. Static Gripping Force (kN)	許容最高回転速度 Max. Speed (min⁻¹)	重量 (kg)	慣性モーメント Moment of inertia (kg·m²)	適合シリンダ Matching Cylinder		許容最大油圧 Max. pressure (MPa)	適合ハードジョー Matching Hard top jaw		標準ソフトジョー Matching Soft top jaw	主軸端呼び Spindle nose size
	Max.	Min.								油圧 pressure	エア air		Matching Hard top jaw	Matching Soft top jaw		
N-06A05	165	15	8.5	20	18	52.5	14	0.050	Y1020R/RE47	AY1720R	2.6	HB06B1	SJ06B1	A2-5		
N-08A06	210	23	8.8	21	25	75	47.60	27	0.148	Y1225R/RE47	AY2225R	2.5	HB08A1	SJ08B1	A2-6	
N-10A06	254	24	8.8	25	29	108	40.10	40	0.335	Y1225R/RE47	AY2225R	2.8	HB10A1	SJ10B1	A2-6	
N-10A08	254	24	8.8	25	29	108	40.10	40	0.328	Y1225R/RE47	AY2225R	2.8	HB10A1	SJ10B1	A2-8	
N-12A06	304	26	10.5	30	41	156	33.80	67	0.760	Y1530R/RE47	-	2.7	HB12B1	SJ12A1	A2-6	
N-12A08	304	26	10.5	30	41	156	33.80	66	0.753	Y1530R/RE47	-	2.7	HB12B1	SJ12A1	A2-8	
N-15A08	381	72	16	35	82	249	30.40	111	2.0	Y2035R/RE47	-	3.2	HB15N1	SJ15N1	A2-8	
N-15A11	381	72	16	35	82	249	30.40	108	2.0	Y2035R/RE47	-	3.2	HB15N1	SJ15N1	A2-11	
N-18A08	450	133	16	35	82	249	27.10	136	3.4	Y2035R/RE47	-	3.2	HB15N1	SJ15N1	A2-8	
N-18A11	450	133	16	35	82	249	27.10	133	3.4	Y2035R/RE47	-	3.2	HB15N1	SJ15N1	A2-11	
N-21A08	530	69	16	35	82	273	19.40	219	7.5	Y2035R/RE47	-	3.2	HB18B2	SJ18A2	A2-8	
N-21A11	530	69	16	35	82	273	19.40	216	7.5	Y2035R/RE47	-	3.2	HB18B2	SJ18A2	A2-11	
N-21A15	530	69	16	35	82	273	19.40	225	7.7	Y2035R/RE47	-	3.2	HB18B2	SJ18A2	A2-15	
N-24A11	610	152	16	35	82	273	17.60	270	12.4	Y2035R/RE47	-	3.2	HB18B2	SJ18A2	A2-11	
N-24A15	610	152	16	35	82	273	17.60	263	12.3	Y2035R/RE47	-	3.2	HB18B2	SJ18A2	A2-15	



CHUCK

立形旋盤用大型チャック Large Power Chuck for Vertical Lathes NV series

立形旋盤でも安心なシールタイプ Low maintenance Power Chuck for Vertical Lathes Sealed 切粉、切削水をダブルシャットアウト Base Jaw to prevent Chips and Coolant ingress



●切粉、切削水侵入防止
Protection against Swarf and Coolant
プロテクタとスクレーパが、チャック内への切粉、切削水侵入を防ぎます。もし侵入しても、バックプレートの水抜き溝が主軸内への切削水封入を防ぎます。
Protector and Scraper at Base Jaw prevent Swarf and Coolant ingress.

●標準ジョー使用 Standard Jaw
スクレーパがボデー装着のため、標準ジョーの使用が可能になりました。特殊ジョーの使用が不要で、設備コストを低減します。
NV series is compatible with standard Hard and Soft Jaws as sealing is at the Base Jaw.

*CE対応品 *CE corresponding

■寸法図 Dimensional Drawings

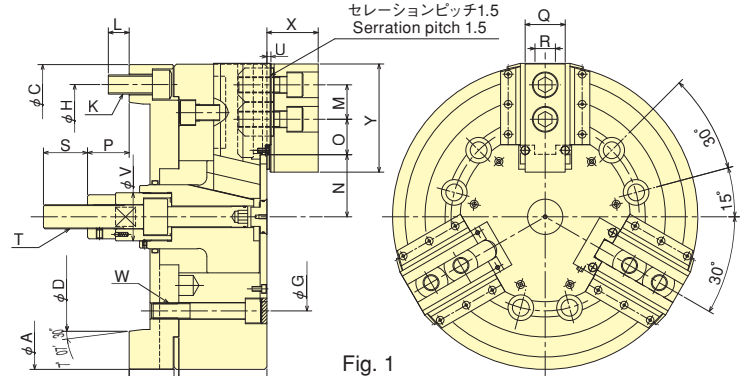

Fig. 1

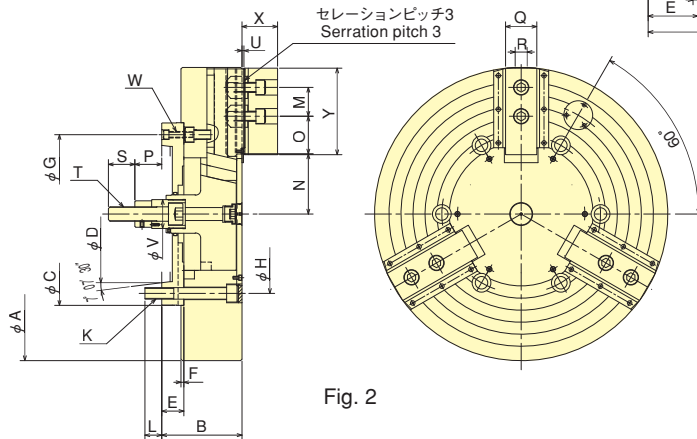
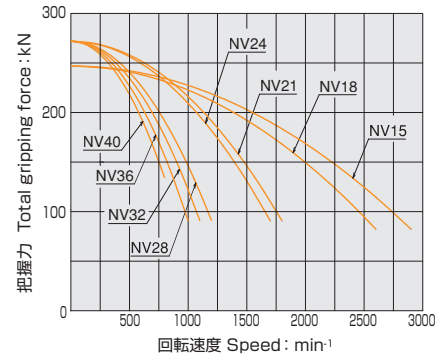

Fig. 2

把握力性能曲線 Gripping Characteristic Graphs

※線は標準ソフトジョーを用いた場合のもので、
※With standard blank soft top jaw.



■寸法表 Dimensions ※NV15、NV18はFig.1による。NV21、NV24、NV28、NV32、NV36、NV40はFig.2による。※NV15&18 are based on Fig.1. NV21~40 are based on Fig.2.

型式 Model	A	B	C	D	E	F	G	H	K	L	M	N max.	N min.	O max.	O min.	P max.	P min.	Q	R	S	T	U	V	W	X	Y
NV15C15	381	172	380	285.775	62	6	235.0	330.2	6-M24	26	43	77.5	69.5	48.75	23.25	91	56	50	25.5	55	M30	5	60	6-M20	64	135
NV18C15	450	172	380	285.775	62	6	235.0	330.2	6-M24	26	43	108	100	48.75	23.25	91	56	50	25.5	55	M30	5	60	6-M20	64	135
NV21C15	530	167	380	285.775	46	6	330.2	330.2	6-M24	35	60	86	78	93.5	27.5	91	56	65	25.0	55	M30	6	60	3-M12	74	180
NV24C15	610	167	380	285.775	46	6	330.2	330.2	6-M24	29	60	125	117	93.5	27.5	91	56	65	25.0	55	M30	6	60	3-M12	74	180
NV28C15	700	167	380	285.775	46	6	330.2	330.2	6-M24	29	60	125	117	141.5	27.5	91	56	65	25.0	55	M30	6	60	3-M12	74	180
NV32C15	800	167	380	285.775	46	6	330.2	330.2	6-M24	29	60	125	117	189.5	27.5	91	56	65	25.0	55	M30	6	60	3-M12	74	180
NV36C15	914	167	380	285.775	46	6	330.2	330.2	6-M24	29	60	125	117	249.5	27.5	91	56	65	25.0	55	M30	6	60	3-M12	74	180
NV40C15	1000	167	380	285.775	46	6	330.2	330.2	6-M24	29	60	125	117	282.5	27.5	91	56	65	25.0	55	M30	6	60	3-M12	74	180

※The above dimensions are based on A2-15 Spindle Nose. A2-11 Spindle Nose is available.

※把握径/把握範囲は標準のソフトジョーを使用した場合。※Gripping dia./gripping range is with standard soft jaws.

型式 Model	把握径 Gripping range mm		ジョーストローク (直径) Jaw Stroke (diameter) mm	プランジャストローク Plunger Stroke mm	許容最大入力 Max. Draw Bar Pull Force kN	最大静的把握力 Max. Gripping Force kN	許容最高回転速度 Max. Speed min ⁻¹	質量 (標準ソフトジョー) Net Weight with Soft top jaws kg	慣性モーメント Moment of inertia kg·m ²	適合シリンダ Matching Cylinder	許容最大油圧 Max. pressure MPa	標準ソフトジョー Matching Soft top jaw	主軸端呼び Spindle nose size
	Max.	Min.											
NV15C15	381	72	16	35	82	247	2900	139	2.7	Y2035R/RE47	3.2	SJ15N1	A2-15
NV18C15	450	133	16	35	82	247	2600	166	4.1	Y2035R/RE47	3.2	SJ15N1	A2-15
NV21C15	530	69	16	35	82	272	1800	227	7.6	Y2035R/RE47	3.2	SJ18A2	A2-15
NV24C15	610	152	16	35	82	272	1700	282	12.8	Y2035R/RE47	3.2	SJ18A2	A2-15
NV28C15	700	152	16	35	82	272	1200	360	21.9	Y2035R/RE47	3.2	SJ18A2	A2-15
NV32C15	800	152	16	35	82	272	1100	472	37.2	Y2035R/RE47	3.2	SJ18A2	A2-15
NV36C15	914	152	16	35	82	272	1000	594	62.4	Y2035R/RE47	3.2	SJ18A2	A2-15
NV40C15	1000	152	16	35	82	272	800	738	91.5	Y2035R/RE47	3.2	SJ18A2	A2-15

※上記は主軸端がA2-15の場合の仕様です。A2-11への対応も可能です。
※The above dimensions are based on A2-15 Spindle Nose. A2-11 Spindle Nose is available.



CHUCK

2爪中実パワーチャック 2-Jaw Closed Center Power Chuck (NLT-Long Stroke) NT・NLT series

異形加工物の把握に最適

Best suited for gripping irregular shaped components

*CE対応品 *CE corresponding

■寸法図 Dimensional Drawings

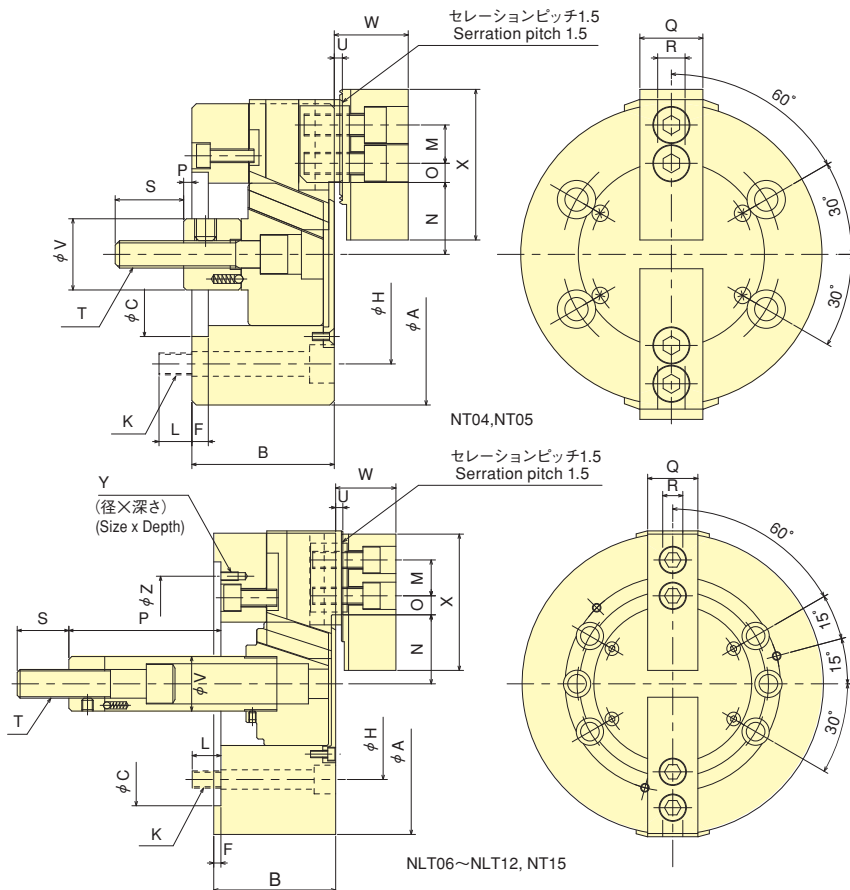

スタンダードチャック
Standard Chuck

把握力性能曲線 Gripping Characteristic Graphs

※線は標準ソフトジョーを用いた場合のもので、
※With standard blank soft top jaw.

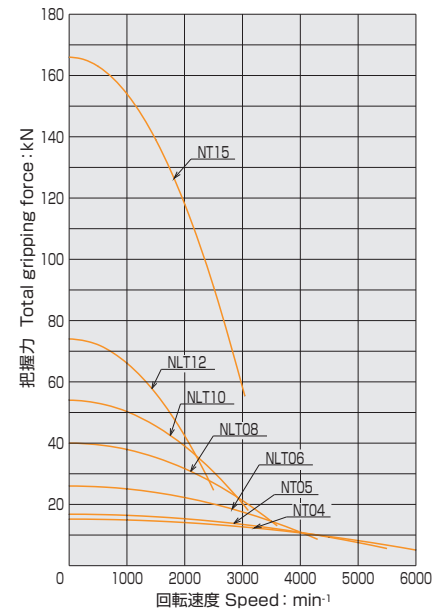

■寸法表 Dimensions

型式 Model	A	B	C (H6)	F	H	K	L	M	N max.	N min.	O max.	O min.	P max.	P min.	Q	R	S	T	U	V	W	X	Y	Z
NT04	110	52	60	6	80	4-M8	12	14	23.3	20.1	10.25	8.75	18	3	23	10	25	M10	3	26	27	55	-	-
NT05	135	55	80	7	100	4-M8	14	19	30.4	27.2	11.5	7	9	-6	23	10	35	M12	3	28	29	62	-	-
NLT06	165	74	140	5	104.8	6-M10	14	20	40.5	34	13.75	9.25	101.5	81.5	31	12	36	M16	4	34	35	72	4M6×10	116
NLT08	210	85	170	5	133.4	6-M12	20	25	48.1	40	21	12	131	106	35	14	36	M20	5	38	42	95	3M6×12	150
NLT10	254	89	220	5	171.4	6-M16	18	30	54.4	45.35	29.5	11.5	161	133	40	16	36	M20	5	45	46	110	3M8×15	190
NLT12	304	106	220	6	171.4	6-M16	18	30	65.7	56	42.75	12.75	163	133	50	18	36	M20	5	50	54	129	3M8×15	190
NT15	381	114	300	6	235	6-M20	30	43	77.5	69.5	48.75	23.25	104	69	50	25.5	55	M30	2	55	61	135	3M10×20	260

■仕様表 Specifications

※許容最高回転速度は、実測値によります。 *Max. speed is shown using actual test data.

※把握径/把握範囲は標準のソフトジョーを使用した場合。 *Gripping dia./gripping range is with standard soft jaws.

型式 Model	把握径 Gripping range		ジョーストローク (直径) Jaw Stroke (diameter)	フランジストローク Plunger Stroke	許容最大入力 Max. Draw Bar Pull Force	最大静的把握力 Max. Gripping Force	許容最高回転速度 Max. Speed	質量 (標準ソフトジョー付) Net Weight with Soft top jaws	慣性モーメント Moment of inertia	適合シリンダ Matching Cylinder	許容最大油圧力 Max. pressure	標準ソフトジョー Matching Soft top jaw
	Max.	Min.										
NT04	110	7	6.4	15	5.3	15.2	6000	3.8	0.007	Y0715R/RE01C	1.68	SJ04A1T
NT05	135	20	6.4	15	5.3	16.8	5500	5.8	0.013	Y0715R/RE01C	1.68	SJ05A1T
NLT06	165	25	13	20	14	26	4300	12.5	0.043	Y1020R/RE47	2.06	SJ06A1T
NLT08	210	26	16.2	25	20	40	3600	24	0.133	Y1225R/RE47	2.03	SJ08A1
NLT10	254	30	18.1	28	27	54	3100	35.5	0.293	Y1530R/RE47	1.93	SJ10A1
NLT12	304	36	19.4	30	36	74	2500	60.5	0.708	Y1530R/RE47	2.50	SJ12A1
NT15	381	80	16	35	54.7	166	3040	93	1.790	Y2035R/RE47	2.1	SJ15N1T

※3爪から2爪への変更は、バックプレートを交換する事で取付可能です。 *Altering Back Plate enables to change over 3-Jaw Chuck into 2-Jaw Chuck.



CHUCK

中実ロングストロークパワーチャック Closed Centre Power Chuck (Long Stroke) NL series

2倍のストローク Extra Long Jaw Stroke

突起物ワークも確実把握

Flange work-pieces securely gripped

*CE対応品 *CE corresponding



■ 寸法図 Dimensional Drawings

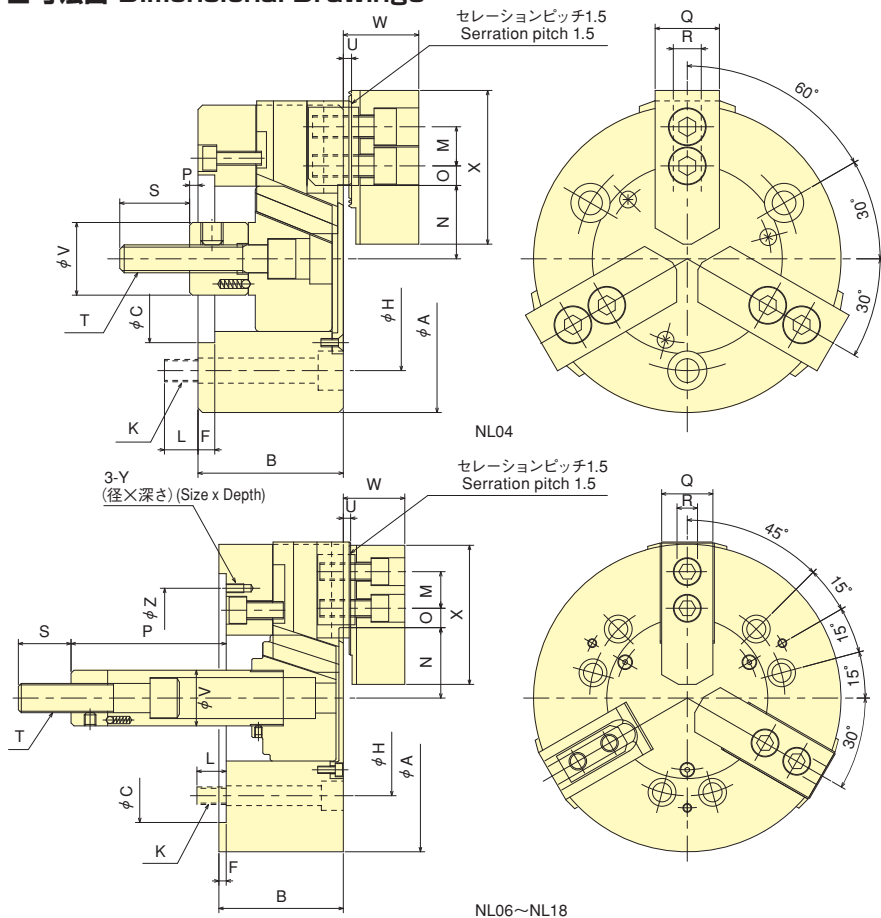

把握力性能曲線 Gripping Characteristic Graphs

※線は標準ソフトジョーを用いた場合のものです。
※With standard blank soft top jaw.

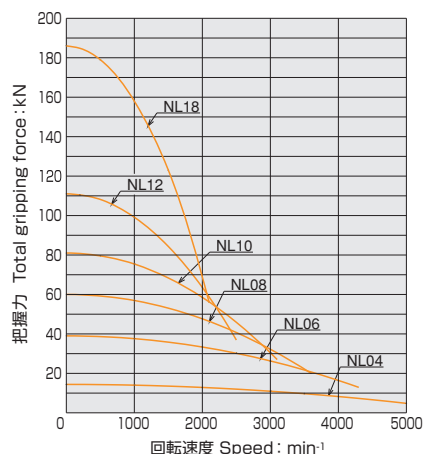

■ 寸法表 Dimensions

寸法 Model	A	B	C (H6)	F	H	K	L	M	N max.	N min.	O max.	O min.	P max.	P min.	Q	R	S	T	U	V	W	X	Y	Z
NL04	110	52	60	6	80	3-M 8	12	14	26.5	20.45	9.75	6.75	18	3	23	10	25	M10	3	26	27	55	-	-
NL06	165	74	140	5	104.8	6-M10	14	20	40.5	34	13.75	9.25	101.5	81.5	31	12	36	M16	4	34	35	72	M6×10	116
NL08	210	85	170	5	133.4	6-M12	20	25	48.1	40	20.75	11.75	131	106	35	14	36	M20	5	38	42	95	M6×12	150
NL10	254	89	220	5	171.4	6-M16	18	30	54.4	45.35	29.5	11.5	161	133	40	16	36	M20	5	45	46	110	M8×15	190
NL12	304	106	220	6	171.4	6-M16	18	30	65.7	56	42.75	12.75	47	17	50	18	46	M24	5	50	54	129	M8×15	190
NL18	450	114	300	6	235	6-M20	30	43	110.5	97.5	47.25	23.25	97	57	50	25.5	55	M30	2	55	61	135	M10×20	260

※NL18はシリンダが特殊となりますので、別途打合せとさせていただきます。
※When using NL18, a special cylinder is required.

■ 仕様表 Specifications

※把握径/把握範囲は標準のソフトジョーを使用した場合。※Gripping dia./gripping range is with standard soft jaws.

仕様 Model	把握径 Gripping range mm	ジョー Stroke (直径) mm	プランジャ Plunger Stroke mm	許容最大入力 Max. Draw Bar Pull Force kN	最大静的把握力 Max. Gripping Force kN	許容最高回転速度 Max. Speed min⁻¹	質量 (標準ソフトジョー付) Net Weight with Soft top jaws kg	慣性モーメント Moment of inertia kg·m²	適合シリンダ Matching Cylinder	許容最大油圧力 Max. pressure MPa	標準ソフトジョー Matching Soft top jaw	適合ハードジョー Matching Hard top jaw
NL04	110	9	12.1	15	10	5000	4.1	0.008	Y0715R/RE01C	2.9	SJ04B1	-
NL06	165	21	13	20	21	39	4300	12	Y1020R/RE47	3.0	SJ06B1	HB06B1
NL08	210	21	16.2	25	30	60	3600	22.9	Y1225R/RE47	2.9	SJ08B1	HB08A1
NL10	254	24	18.1	28	40	81	3100	34.6	Y1530R/RE47	2.8	SJ10A1	HB10A1
NL12	304	29	19.4	30	54	111	2500	60	Y1530R/RE47	3.6	SJ12A1	HB12B1
NL18	450	122	26	40	91	186	2100	124	Y2035RE47**	3.5	SJ15N1	-



CHUCK

中実ロングストロークパワーチャック (ショートテーパ) Closed Centre Power Chuck (Long Stroke, Direct Mount) **NL-A series**

スピンドルノーズ対応バックプレート付き
Chuck Adaptor is equipped to suit Spindle Nose
突起物ワークも確実に把握
Flange work-pieces securely gripped



スタンダードチャック

*CE対応品 *CE corresponding

■ 寸法図 Dimensional Drawings

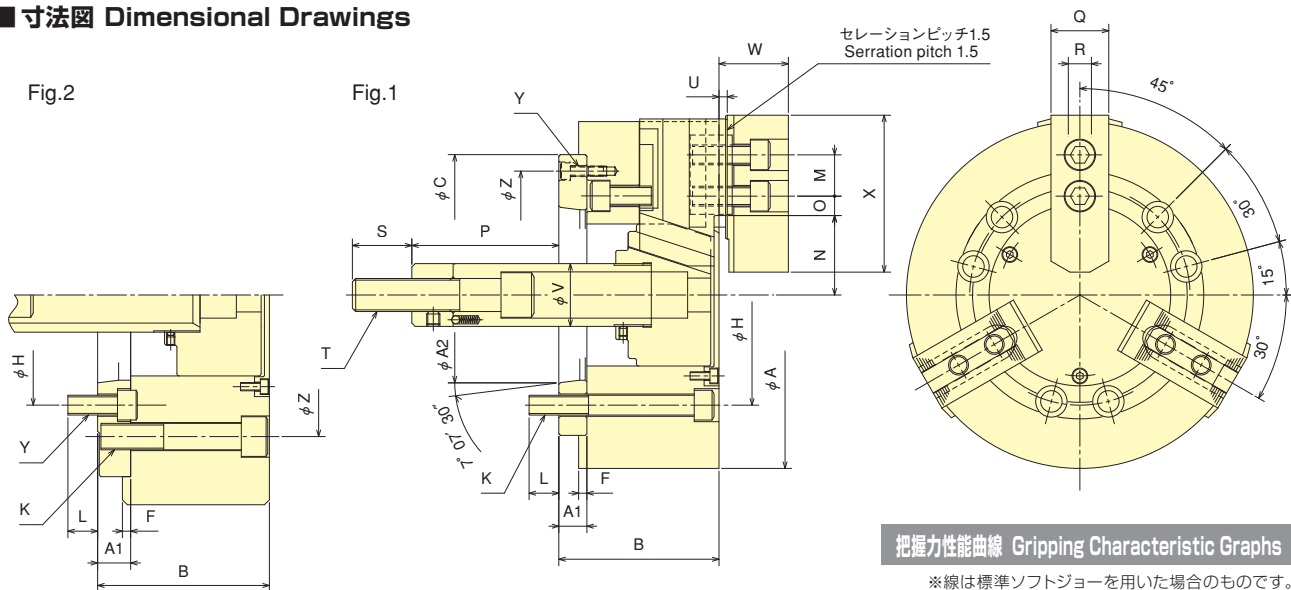

把握力性能曲線 Gripping Characteristic Graphs

*線は標準ソフトジョーを用いた場合のものです。
*With standard blank soft top jaw.

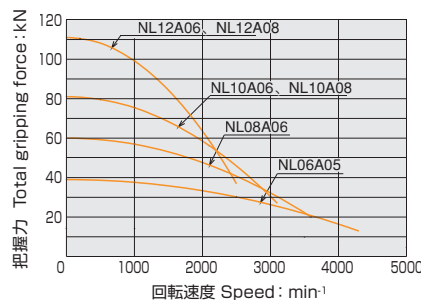

■ 寸法表 Dimensions *NL10A06, NL12A06はFig.2による。*NL10A06 and NL12A06 are based on Fig. 2.

寸法 型式 Model	A	B	C	F	H	K	L	M	N max.	N min.	O max.	O min.	P max.	P min.	Q	R	S	T	U	V	W	X	Y	Z	A1	A2
NL06A05	165	84	140	5	1048	6-M10	14	20	40.5	34	13.75	9.25	86.5	66.5	31	12	36	M16	4	34	35	72	3-M6	116	15	82.563
NL08A06	210	97	170	5	1334	6-M12	18	25	48.1	40	20.75	11.75	114	89	35	14	36	M20	5	38	42	95	3-M6	150	17	106.375
NL10A06	254	104	220	5	1334	6-M16	18	30	54.4	45.35	29.5	11.5	141	113	40	16	36	M20	5	45	46	110	6-M12	171.4	20	106.375
NL10A08	254	102	220	5	171.4	6-M16	25	30	54.4	45.35	29.5	11.5	143	115	40	16	36	M20	5	45	46	110	3-M8	190	18	139.719
NL12A06	304	120	220	6	1334	6-M16	18	30	65.7	56	42.75	12.75	3	-27	50	18	46	M24	5	50	54	129	6-M12	171.4	20	106.375
NL12A08	304	118	220	6	171.4	6-M16	25	30	65.7	56	42.75	12.75	1	-29	50	18	46	M24	5	50	54	129	3-M8	190	18	139.719

■ 仕様表 Specifications *把握径/把握範囲は標準のソフトジョーを使用した場合。*Gripping dia./gripping range is with standard soft jaws.

仕様 型式 Model	把握径 Gripping range mm	ジョー Stroke mm	径 直径 直径 mm	プランジャ ストローク Plunger Stroke mm	許容最大入力 Max. Draw Bar Pull Force kN	最大静的把握力 Max. Gripping Force kN	許容最高回転速度 Max. Speed min ⁻¹	質量 Net Weight with Soft top jaws kg	慣性モーメント Moment of Inertia kg·m ²	適合シリンダ Matching Cylinder	許容最大油圧 Max. pressure MPa	標準ソフトジョー Matching Soft top jaw	適合ハードジョー Matching Hard top jaw	主軸呼び Spindle nose size
NL06A05	165	21	13	20	21	39	4300	12.5	0.048	3.0	SJ06B1	HB06B1	A2-5	
NL08A06	210	21	16.2	25	30	60	3600	24.5	0.148	2.9	SJ08B1	HB08A1	A2-6	
NL10A06	254	24	18.1	28	40	81	3100	40	0.335	2.8	SJ10A1	HB10A1	A2-6	
NL10A08	254	24	18.1	28	40	81	3100	37.6	0.326	2.8	SJ10A1	HB10A1	A2-8	
NL12A06	304	29	19.4	30	54	111	2500	64.6	0.759	3.6	SJ12A1	HB12B1	A2-6	
NL12A08	304	29	19.4	30	54	111	2500	63	0.750	3.6	SJ12A1	HB12B1	A2-8	



CHUCK

中実超ロングストロークパワーチャック Mega-Long Stroke Chuck ML series

常識を超えるロングストローク
Exceptionally long Jaw stroke
飛越し把握に最適
Suitable for Multi-Diameter gripping and flange work-pieces

*CE対応品 *CE corresponding



スタンダードチャック

把握例 Gripping Example

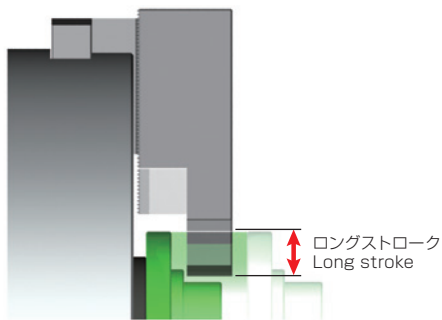

- 飛越しの必要なワーク加工に最適です。
- Suitable for work-pieces with large flange

把握力性能曲線 Gripping Characteristic Graphs

※線は標準ソフトジョーを用いた場合のもので、
※With standard blank soft jaw.

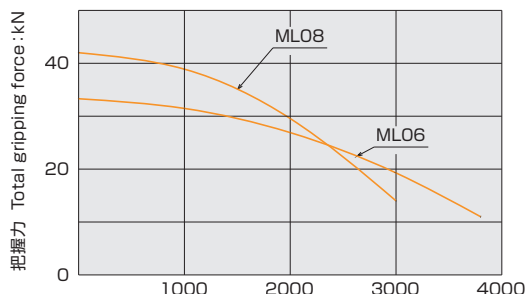

寸法図 Dimensional Drawings

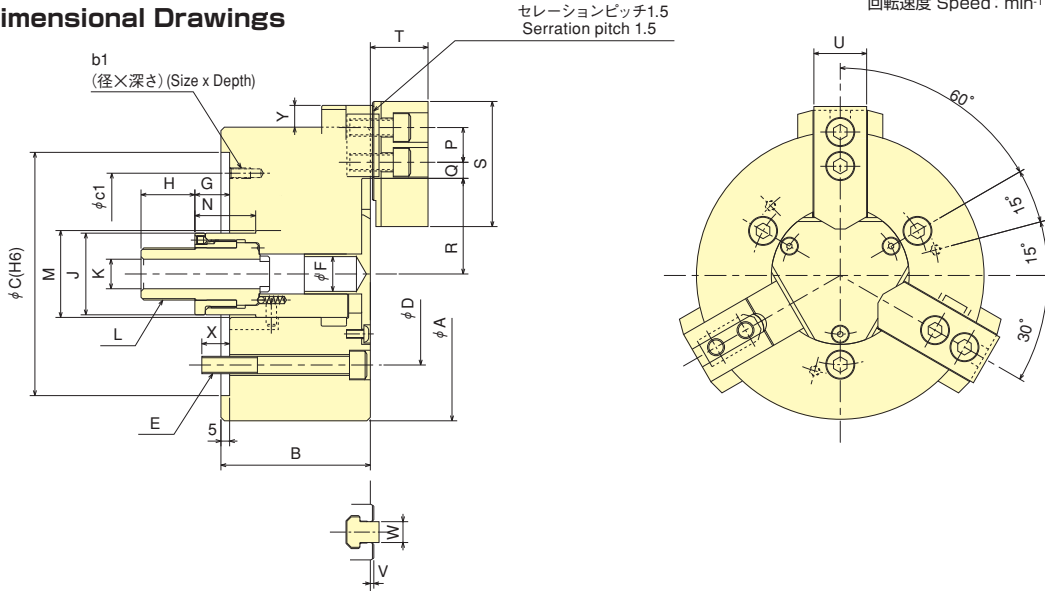

寸法表 Dimensions

寸法 Dimensions 型式 Model	A	B	C	D	E	F	G max.	G min.	H	J	K	L	M	N	P	Q max.	Q min.
ML06	169	86	140	104.8	3-M10	20	40	20	31	47	17	M30×1.5	50	35	20	13.75	9.25
ML08	215	99	170	133.4	3-M12	20	34	9	34	54	17	M33×1.5	70	29	25	17.75	11.75

寸法 Dimensions 型式 Model	R max.	R min.	S	T	U	V	W	X	Y max.	b1	c1
ML06	55	35	72	33.2	31	2	12	16	12.5	3-M6×12	116
ML08	65.6	40.6	95	39.2	35	2	14	21	12.1	3-M6×12	150

仕様表 Specifications ※把握径/把握範囲は標準のソフトジョーを使用した場合。※Gripping dia./gripping range is with standard soft jaws.

仕様 Specifications 型式 Model	把握径 Gripping range mm		ジョーストローク (直径) Jaw Stroke (diameter) mm	プランジャストローク Plunger Stroke mm	許容最大入力 Max. Draw Bar Pull Force kN	最大静的把握力 Max. Gripping Force kN	許容最高回転速度 Max. Speed min ⁻¹	質量 (標準ソフトジョー付) Net Weight with Soft top jaws kg	慣性モーメント Moment of Inertia kg·m ²	適合シリンダ Matching Cylinder	許容最大油圧 Max. pressure MPa	標準ソフトジョー Matching Soft top jaw
ML06	Max.	Min.	40	20	36.0	33.0	3800	13.7	0.048	Y1225R/RE47	3.46	SJ06B1
ML08	Max.	Min.	50	25	45.0	42.0	3000	26.0	0.167	Y1530R/RE47	3.06	SJ08B1



CHUCK

2爪中実超ロングストロークパワーチャック 2-Jaw Mega-Long Stroke Chuck MLT series

常識を超えるロングストローク
Exceptionally long Jaw stroke
異形ワークに最適
Best suited for gripping irregular shaped components

*CE対応品 *CE corresponding



スタンダードチャック
Standard Chuck

把握例 Gripping Example

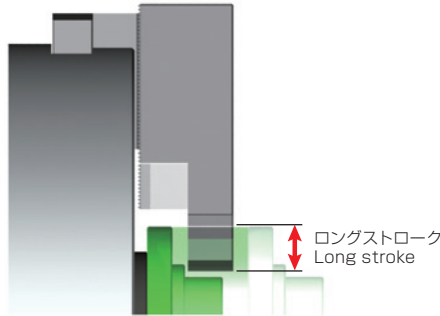

- バルブ等のワーク加工に最適です。
また、ストロークが大きいことでジョーの共通化が図れます。
- Suitable for machining of valves.
Common jaw sets can be used due to long stroke.

把握力性能曲線 Gripping Characteristic Graphs

※線は標準ソフトジョーを用いた場合のもので、
※With standard blank soft top jaw.

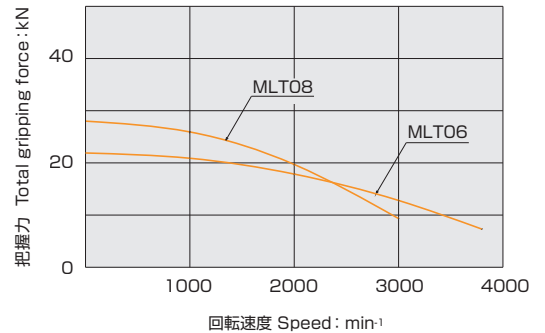

寸法図 Dimensional Drawings

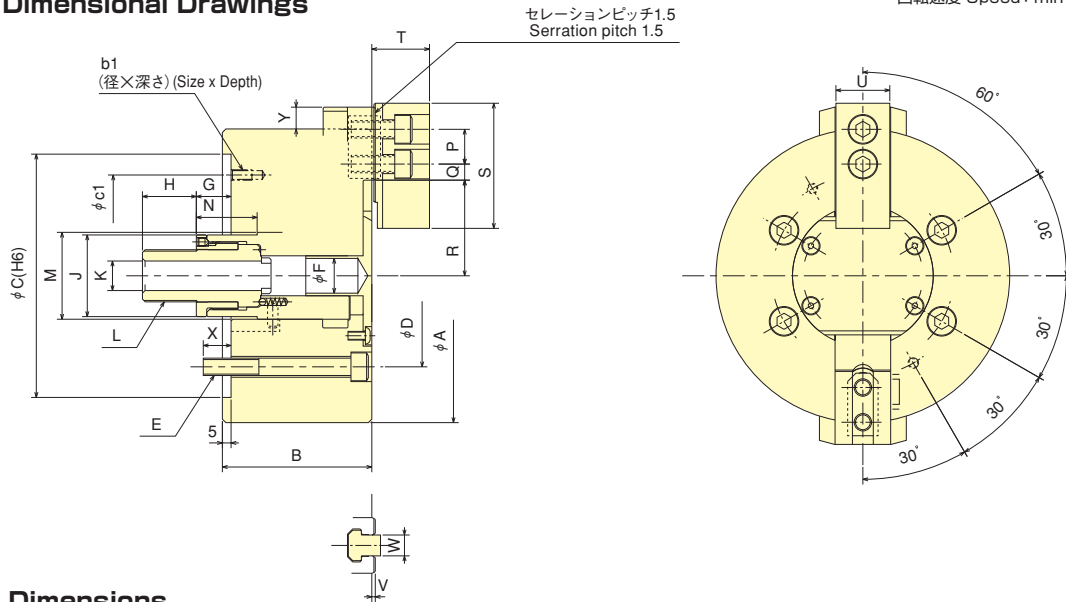

寸法表 Dimensions

寸法 Dimensions Model	A	B	C	D	E	F	G max.	G min.	H	J	K	L	M	N	P	Q max.	Q min.
MLT06	169	86	140	104.8	4-M10	20	40	20	31	47	17	M30×1.5	50	35	20	13.75	9.25
MLT08	215	99	170	133.4	4-M12	20	34	9	34	54	17	M33×1.5	70	29	25	18	12

寸法 Dimensions Model	R max.	R min.	S	T	U	V	W	X	Y max.	b1	c1
MLT06	55	35	72	33.2	31	2	12	16	12.5	2-M6×12	116
MLT08	65.6	40.6	95	39.2	35	2	14	21	12.1	3-M6×12	150

仕様表 Specifications ※把握径/把握範囲は標準のソフトジョーを使用した場合。*Gripping dia./gripping range is with standard soft jaws.

仕様 Specifications Model	把握径 Gripping range mm		ジョーストローク(直径) Jaw Stroke(diameter) mm	プランジャストローク Plunger Stroke mm	許容最大入力 Max. Draw Bar Pull Force kN	最大静的把握力 Max. Gripping Force kN	許容最高回転速度 Max. Speed min ⁻¹	質量(標準ソフトジョー付) Net Weight with Soft top jaws kg	慣性モーメント Moment of inertia kg·m ²	適合シリンダ Matching Cylinder	許容最大油圧力 Max. pressure MPa	標準ソフトジョー Matching Soft top jaw
MLT06	Max.	Min.	40	20	24	21.9	3800	13.7	0.054	Y1225R/RE47	2.39	SJ06A1T
MLT08	Max.	Min.	50	25	30	28	3000	25.7	0.164	Y1530R/RE47	2.13	SJ08A1

※3爪から2爪への変更は、バックプレートを交換する事で取付可能です。*Altering Back Plate enables to change over 3-Jaw Chuck into 2-Jaw Chuck.



CHUCK

1爪中実超ロングストロークパワーチャック 1-Jaw Mega-Long Stroke Chuck MLV series

**常識を超えるロングストローク
Exceptionally long Jaw stroke
ジグチャックに最適
Best suited for jig work-piece fixturing**

*CE対応品 *CE corresponding

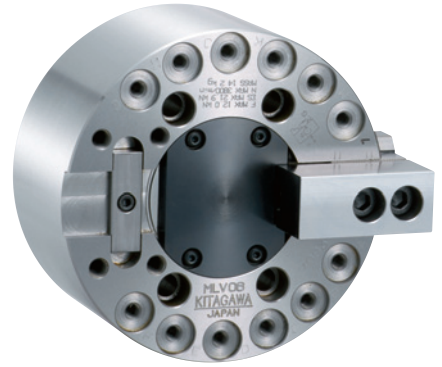

把握例 Gripping Example

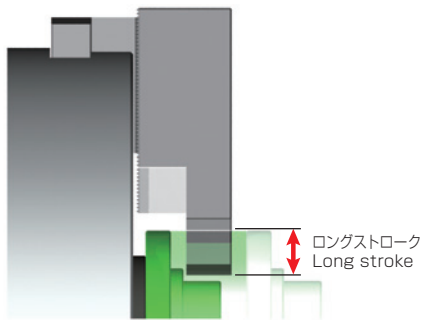

把握状態例 Gripping Examples

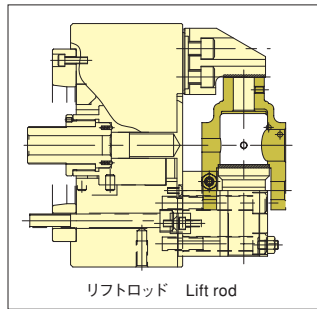

- 固定ジョーのみ交換すれば段取交換、治具代は半分で対応できます。
Halve the set-up time and increase performance.

把握力性能曲線 Gripping Characteristic Graphs

※線は標準ソフトジョーを用いた場合のものです。
※With standard blank soft top jaw.

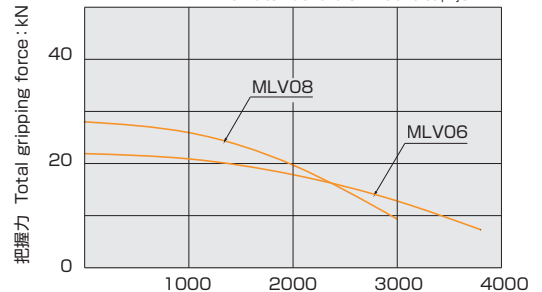

寸法図 Dimensional Drawings

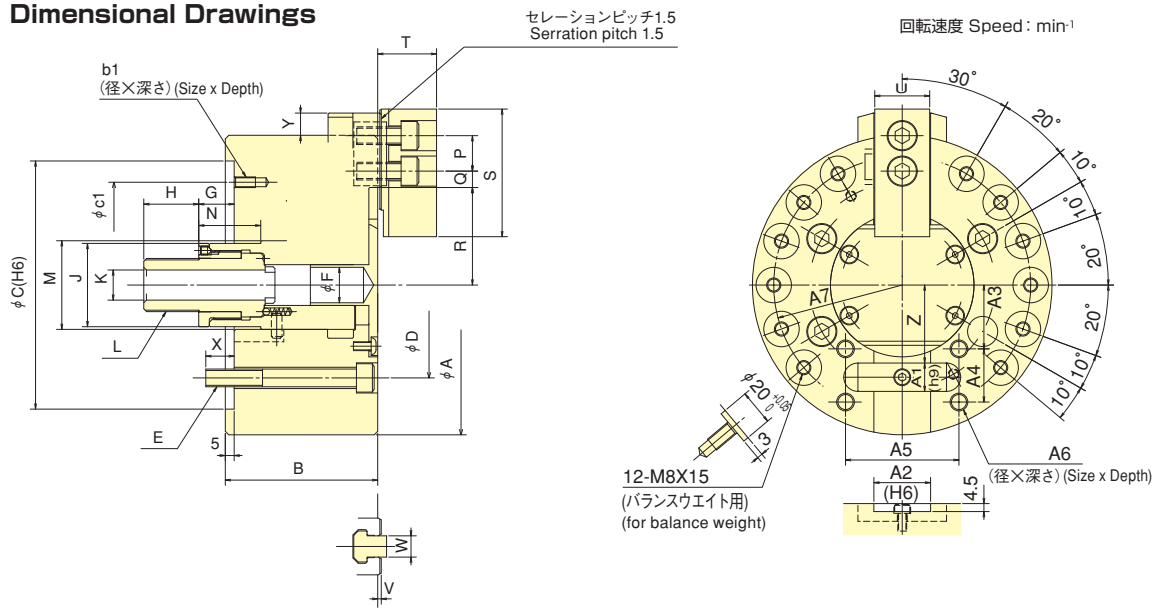

寸法表 Dimensions

寸法 型式 Model	A	B	C	D	E	F	G max.	G min.	H	J	K	L	M	N	P	Q max.	Q min.
MLV06	169	86	140	104.8	4-M10	20	40	20	31	47	17	M30×1.5	50	35	20	13.75	9.25
MLV08	215	99	170	133.4	4-M12	20	34	9	34	54	17	M33×1.5	70	29	25	18	12

寸法 型式 Model	R max.	R min.	S	T	U	V	W	X	Y max.	Z	A1	A2	A3	A4	A5	A6	A7	b1	c1
MLV06	55	35	72	33.2	31	2	12	16	12.5	44	16	32	36	30	64	4-M10×16	72.5	2-M6×12	116
MLV08	65.6	40.6	95	39.2	35	2	14	21	12.1	60	18	37	51	36	70	4-M12×20	95	3-M6×12	150

仕様表 Specifications ※把握径/把握範囲は標準のソフトジョーを使用した場合。※Gripping dia./gripping range is with standard soft jaws.

仕様 型式 Model	把握径 Gripping range mm	ジョーストローク Jaw Stroke mm	プランジャストローク Plunger Stroke mm	許容最大入力 Max. Draw Bar Pull Force kN	最大静的把握力 Max. Gripping Force kN	許容最高回転速度 Max. Speed min ⁻¹	質量(標準ソフトジョー付) Net Weight with Soft top jaws kg	慣性モーメント Moment of inertia kg·m ²	適合シリンダ Matching Cylinder	許容最大油圧力 Max. pressure MPa	標準ソフトジョー Matching Soft top jaw
MLV06	Max. 169 Min. 37	20	20	12.0	21.9	3800	13.2	0.050	Y1225R/RE47	1.32	SB06A1V
MLV08	Max. 215 Min. 38	25	25	15.0	28.0	3000	25.0	0.155	Y1530R/RE47	1.19	SB08A1V



CHUCK

4爪中実パワーチャック

4-Jaw Lever Type Power Operated Chuck with Closed Centre

HW series

角材、楕円形状など異形物も確実に把握

Steadily grips block, oval, or any irregular shaped work-pieces

セルフセンタリング構造

Self Centring Mechanism (2+2 Jaws)



スタンダードチャック

●セルフセンタリング(求心構造) Self Centring Mechanism

対向した2対のジョーがそれぞれ求心作用を行ないます。角形状、ダ円形状等の異形物チャッキングに最適です。
2 independent Jaw sets give Dual Action clamping allowing irregular shapes to be easily gripped. Consequently, it is the best to chuck a deformed work-piece such as a square shape and elliptical shape.

●ロングストローク Long Stroke

ジョーストロークが大きくチャッキング寸法のバラツキが大きい場合でも十分な把握範囲があります。
Long Jaw Stroke ensures components with variation are gripped securely.

*CE対応品 *CE corresponding

■寸法図 Dimensional Drawings

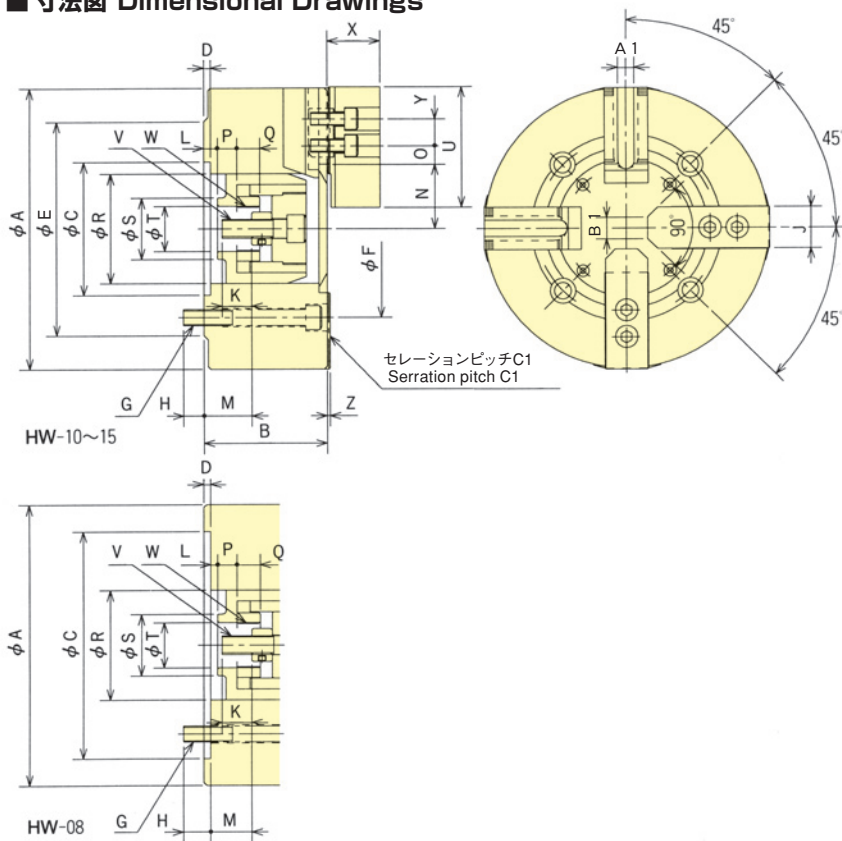

把握状態例 Gripping Examples

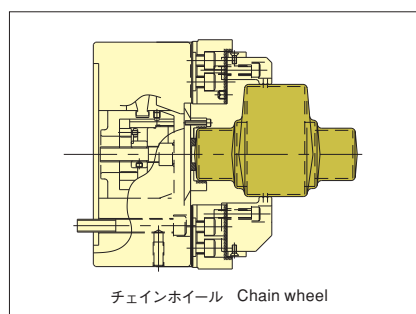

把握力性能曲線 Gripping Characteristic Graphs

※線は標準ソフトジョーを用いた場合のもので、
※With standard blank soft top jaw.

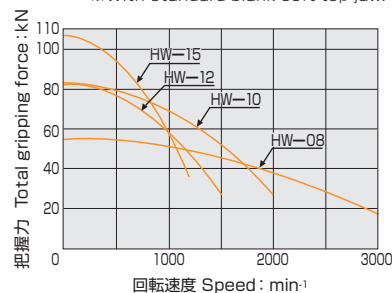

■寸法表 Dimensions

型 式 Model	寸法 Dimensions																															
	A	B	C(H6)	D	E	F	G	H	J	K	L max.	L min.	M max.	M min.	N max.	N min.	O max.	O min.	P	Q	R	S	T	U	V	W	X	Y	Z	A1	B1	C1
HW-08	210	91	170	5	-	133.4	4-M12	20	31	29	10.5	-6.5	39	22	50.3	43.7	28.75	9.25	17.5	17	82	46	34	90	M14x20	M34x1.5	39	20	2	12	16	1.5
HW-10	270	110	120	5.5	200	170	4-M16	24	40	31	18	-4	49	27	64	56	28	13	20	20	103	58	42	110	M16x20	M42x1.5	45	30	5	16	-	3.0
HW-12	304	110	120	5.5	200	170	4-M16	24	40	31	18	-4	49	27	64	56	49	13	20	20	103	58	42	110	M16x20	M42x1.5	45	30	5	16	-	3.0
HW-15	381	135	195	7.5	285	235	4-M20	30	50	55	26	1	59.5	34.5	78	69.5	66.5	12.5	18.5	24	130	78	55	129	M20x25	M55x2	53	38	5	18	-	3.0

■仕様表 Specifications

※把握径/把握範囲は標準のソフトジョーを使用した場合。*Gripping dia./gripping range is with standard soft jaws.

型 式 Model	把握径 Gripping range		ジョーストローク(直径) Jaw Stroke(diameter)	プランジャストローク Plunger Stroke	許容最大入力(プランジャ1体分) Max. Input Force (Per of Plunger)	最大静的把握力(ジョー1個分) Max. Static Gripping Force (Per of Jaw)	許容最高回転速度 Max. Speed	質量(標準ソフトジョー付) Net Weight with Soft top jaws	慣性モーメント Moment of inertia	適合シリンダ Matching Cylinder	許容最大油圧力 Max. pressure	標準ソフトジョー Matching Soft top jaw
	Max.	Min.										
HW-08	210	23	13.2	17	16.5	28	3000	23	0.153	YW1220R/RE	1.71	SJ08B1Q
HW-10	270	50	16	22	23	42	2000	50	0.500	YW1225R/RE	2.29	SJ10A2Q
HW-12	304	50	16	22	23	42	1500	58	0.700	YW1225R/RE	2.29	SJ10A2Q
HW-15	381	59	17	25	28	54	1200	118	2.25	YW1225R/RE	2.73	SJ15A2Q

※チャックトータルでは許容最大入力、最大静的把握力とも上記表の2倍となります。

※YWシリンダとの組合せで爪の移動順位を指定することはできません。(指定必要の場合は問合せください)

※In chuck total, both maximum allowable input value and static gripping force value are double on the above list.

※The movement order of jaw cannot be assigned in combination with YW cylinder. (Contact to Kitagawa when assignment is required.)



CHUCK

フロント中空エアチャック Air-Operated Self Contained Chuck UVE-K series

エアシリンダ内蔵 Built-in Pneumatic Cylinder

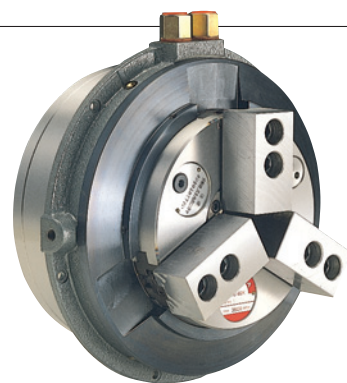

■ 寸法図 Dimensional Drawings

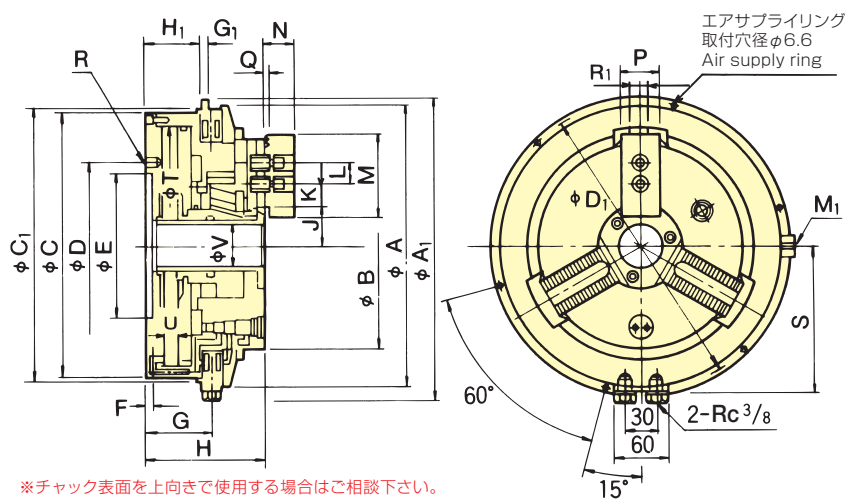

※チャック表面を上向きで使用する場合はご相談下さい。
※Consult us in case of Chuck face is used for upper position.

把握力性能曲線 Gripping Characteristic Graphs

※線はエア圧0.6MPaで標準ソフトジョーを用いた場合のものであります。
※Each curve shows air pressure 0.6MPa. This is a case that standard soft jaws are used.

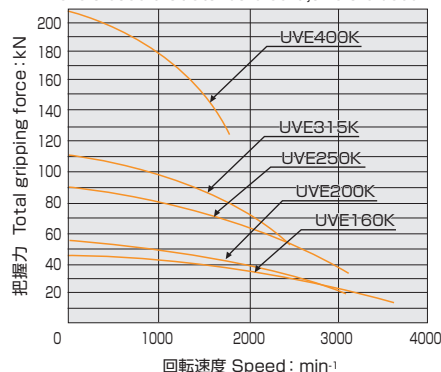

■ 寸法表 Dimensions

寸法 Model	A	B	C	D	E (H7)	F	G	H	J max.	J min.	K max.	K min.	L	M	N	P	Q	R	S	T	U	V	A ₁	C ₁ (h6)	D ₁	G ₁	H ₁ ±0.1	M ₁	R ₁
UVE160K	250	170	230	180	160	6.5	83	137	33.5	29.3	19.25	10.25	25	76.5	38.5	40	2.25	6-M10	138	205	24	38	273	240	260	6	71	M10	14
UVE200K	280	200	260	210	185	8	82.5	141	43	38.8	20.25	11.25	30	110	43	40	2.25	6-M10	150	230	24	50	302	275	288	6	69	M10	16
UVE250K	330	250	310	260	235	8	87.5	151	47.5	42.6	39.75	12.75	30	110	43	40	2.25	6-M10	175	280	28	60	350	320	336	6	74	M12	16
UVE315K	385	315	365	315	290	8	90.5	155	64	59.1	46.25	14.75	38	129	51	50	2.25	6-M10	206	335	28	92	410	380	395	8	77	M12	18
UVE400K	495	400	475	340	300	8	118	200	86	79	37.5	16.5	60	156	71	62	3.3	6-M16	257	440	40	120	518	485	505	8	104	M16	22

■ 仕様表 Specifications ※把握径/把握範囲は標準のソフトジョーを使用した場合。※Gripping dia./gripping range is with standard soft jaws.

仕様 Model	真通穴径 Thru-Hole mm	把握径 Gripping range mm Max. Min.	ジョーストローク Jaw Stroke (直径) mm	プランジャ ストローク Plunger Stroke mm	最大静的把握力 (エア圧0.6MPa) Max. Gripping Force (at air pressure 0.6MPa) kN	許容最高 回転速度 Max. Speed min ⁻¹	質量 Net Weight kg	慣性 モーメント Moment of inertia kg·m ²	標準 ソフトジョー Matching Soft top jaw	許容最大 エア圧力 Max. pressure MPa	空気消費量 10mm当り (エア圧0.6MPa) Air cspsumption per 10mm (at air pressure 0.6MPa) ℓ	セレーション ピッチ Serration pitch
UVE160K	38	170 12	8.4	24	45	3600 (3500)	29.5	0.25	SJ06C1	0.6	2.375	1.5
UVE200K	50	200 8	8.4	24	54	3200 (2800)	38.5	0.35	SJ10B1	0.6	2.990	1.5
UVE250K	60	250 18	9.8	28	90	3000 (2200)	61	0.725	SJ10B1	0.6	4.432	1.5
UVE315K	92	315 40	9.8	28	111	2500 (1800)	81	1.45	SJ12C1	0.6	6.343	1.5
UVE400K	120	400 89	14	40	210	1800 (1200)	145	4.375	SJ15A2	0.6	10.943	3

※最高回転数は空気圧0.6MPa、標準ソフトジョー使用、エアサプライリング固定取付時の数値です。エアサプライリングを固定しない場合の回転速度は、()内数値となります。
※爪1個の締付力は、把握力の1/3となります。 ※標準付属品：ソフトジョー、エアプレッシャージョー。
※Maximum speed is shown with each value under air pressure of 0.6MPa, using standard soft jaw and fixed air supply ring. If the air supply ring is not fixed, max. speed in () is applied.
※Gripping force of a jaw is one third of max. gripping force. ※Standard accessories: Soft jaw, air pressure gauge, tools of a set.

■ ハードジョー(特別付属品) Hard Jaw(Option accessories)

型 Model	把握径 Gripping range mm	標準ハードジョー Hard jaw
UVE160K	φ12~φ170	HB06U1
UVE200K	φ14~φ180	HB08U1
UVE250K	φ21~φ225	HB08U1
UVE315K	φ36~φ310	HB12U1
UVE400K	φ80~φ400	HB16U2

※UVE200K・250Kのハードジョーは兼用です。
※UVE500K以上のサイズは仕様打合せの上、製作致します。
※Hard jaw for UVE200K & 250K is same.
※Hard jaw for UVE500K size or more is manufactured under prearrangement.

■ 推奨エア回路図 Recommended air circuit diagram

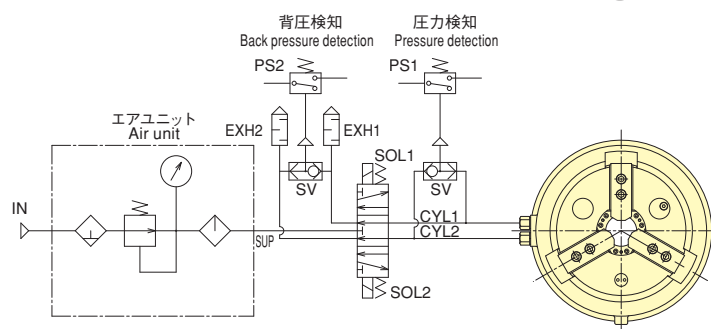



CHUCK

大口徑フロント中空エアチャック Air-Operated Self Contained Chuck UPR series

油井管規格に適合したエアチャック

Air-operated chuck perfect for oil pipe standards

- チャックの着脱が容易な構造 Easy installation
 - 芯出し調整が容易 Easy centering adjustment
 - メンテナンス性の向上。 Service & maintenance improved.
消耗品の部品交換が容易 Easy replacing consumable parts
- *CE対応品 *CE corresponding



スタンダードチャック
Standard Chuck

■ 寸法図 Dimensional Drawings

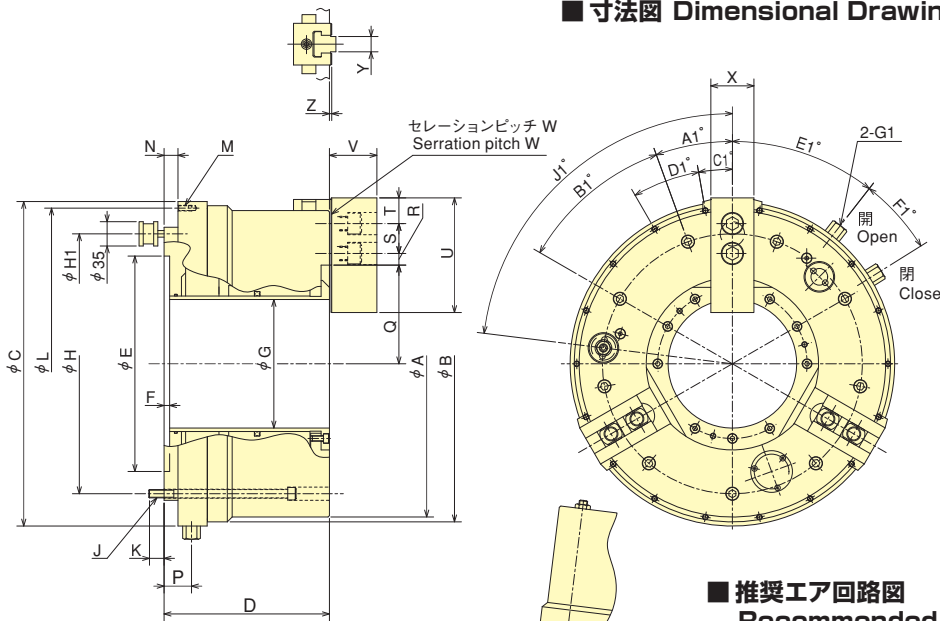

*チャック表面を上向きで使用する場合はご相談下さい。
*Consult us in case of Chuck face is used for upper position.

■ 推奨エア回路図

Recommended air circuit diagram

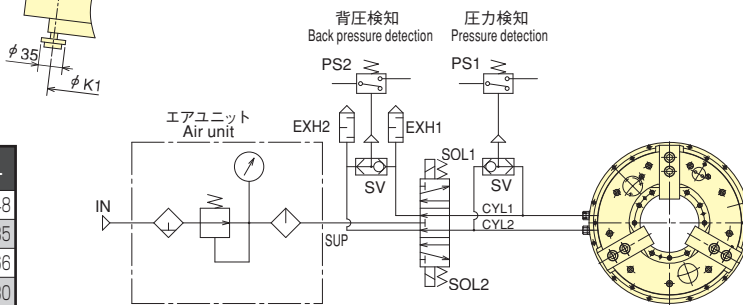

■ 寸法表 Dimensions

型式 Model	A	B	C (0/0.2)	D	E (H7)	F	G	H	J	K	L
UPR450	441	455	467	238	310	8	185	374	9-M12	22	448
UPR600	590	605	605	272	450	8	275	508	12-M12	22	585
UPR650	655	675	685	283	510	8	325	580	12-M16	24	666
UPR710	715	740	750	283	550	8	375	620	9-M16	24	730
UPR910	915	915	925	291	700	10	560	800	12-M16	26	905

型式 Model	M	N	P	Q max.	Q min.	R max.	R min.	S	T	U	V	W	X	Y (h8)	Z	A1	B1	C1	D1	E1	F1	G1	H1	J1	K1
UPR450	18-M8 ねじ深さ Depth 20	20	39.5	142	122	34.75	16.75	43	37	165	68.3	1.5	62	22	3.3	20°	9×40°	10°	18×20°	38°	20°	Rc3/8	374	83°	374
UPR600	18-M8 ねじ深さ Depth 20	20	50	196.5	171.5	32.5	20.5	60	39.5	180	70.5	3	65	25.5	3.3	15°	12×30°	0°	18×20°	25°	20°	Rc3/8	508	60°	508
UPR650	18-M8 ねじ深さ Depth 20	20	50	223	198	38.5	20.5	60	40	209.5	81.3	3	75	30	3.3	15°	12×30°	0°	18×20°	25°	20°	Rc1/2	580	60°	580
UPR710	18-M8 ねじ深さ Depth 20	20	43	248	223	50.5	23.5	60	40	209.5	81.3	3	75	30	3.3	20°	9×40°	0°	18×20°	30°	15°	Rc1/2	620	45°	620
UPR910	18-M8 ねじ深さ Depth 20	33	56	342	317	50.5	23.5	60	40	209.5	81.3	3	75	30	3.3	15°	12×30°	0°	18×20°	30°	15°	Rc1/2	800	60°	800

■ 仕様表 Specifications

*把握径/把握範囲は標準のソフトジョーを使用した場合。*Gripping dia./gripping range is with standard soft jaws.

型式 Model	貫通穴径 Thru-Hole mm	把握径 Gripping range mm		ジョーストローク (直径) Jaw Stroke (diameter) mm		プランジャストローク Plunger Stroke mm	最大静的把握力 Max. Gripping Force kN	許容最高回転速度 Max. Speed min	質量 Net Weight kg	慣性モーメント Moment of inertia kg·m ²	許容最大エア圧力 Max. pressure MPa
		Max.	Min.	早送り Rapid	把握送り Gripping						
UPR450	185	441	131	26	14	53	100	1300	195	5.5	0.6
UPR600	275	590	241	33	17	53.5	120	1100	365	19.7	0.5
UPR650	325	655	239	33	17	53.5	147	1000	476	32.2	0.6
UPR710	375	715	301	33	17	53.5	162	900	532	43.1	0.6
UPR910	560	915	477	33	17	53.5	162	600	735	103	0.5



CHUCK

大口径フロント中空エアチャック

UB series

エアシリンダ内蔵 パイプ加工に最適な大型チャック



- ジョー位置検出が対応可能
- 内圧検知可能
- *CE対応品

■ 寸法図

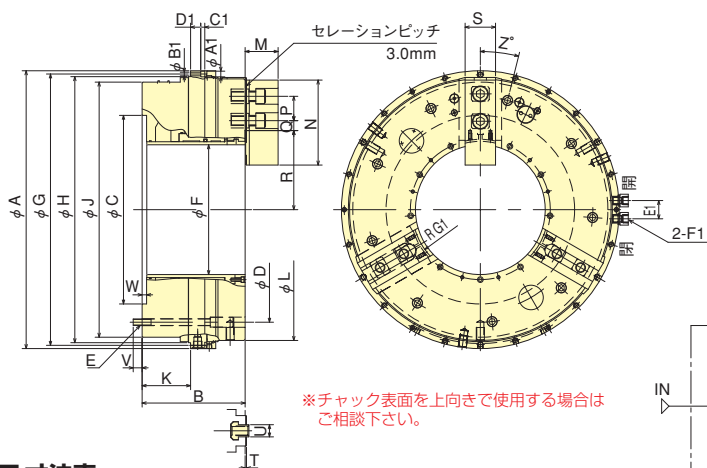

■ 推奨エア回路図

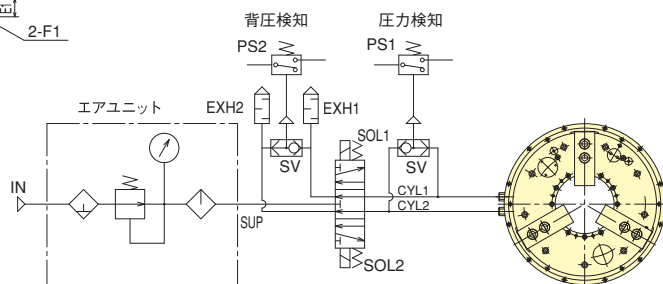

■ 寸法表

型式	A1	B1	C1	D1	E1	F1	G1
UB450K	11	6.6	6.6	25	45	Rc3/8	87.5
UB560K	14	9	9	20	45	Rc1/2	134
UB630K	14	9	10	25	45	Rc1/2	160
UB710K	17	11	11	33	45	Rc1/2	185

型式	A	B	C (H7)	D	E	F	G	H (H7)	J	K	L	M ミレシ	N	P	Q max.	Q min.	R max.	R min.	S	T	U	V	W	Z	
UB450K	494	212	275	373	9-M12	181	481	470	431	98.5	441	67.3	68.7	165	43	41.5	17.5	121.4	114.4	62	3.3	25.5	17	6	20
UB560K	626	230	375	485	6-M16	275	610	595	556	113.5	568	70.5	71.9	180	60	42	18	169	160.5	65	3.3	25.5	24	11	40
UB630K	698	254	465	555	9-M16	320	682	669	629	119.5	645	81.3	82.7	209.5	60	50.5	23.5	195	186.5	75	3.3	30	22	11	14
UB710K	790	252	520	620	9-M16	375	770	745	702	118.5	714	81.3	82.7	209.5	60	62.3	26.3	222.5	211.5	75	3.3	30	24	11	24

■ 仕様表

※把握径/把握範囲は標準のソフトジョーを使用した場合。

型式	貫通穴径 mm	把握径 mm		ジョーストローク (直径) mm	プランジャ ストローク mm	最大静的把握力 kN	許容最高回転速度 min ⁻¹	質量 (標準ソフトジョー付) kg	慣性モーメント kg·m ²	許容最大エア圧力 MPa	空気消費量 10mm当り (エア圧0.6MPa) ℓ
		Max.	Min.								
UB450K	181	441	117	14	40	100	1300	204	5.55	0.6	4.83
UB560K	275	568	215	17	37	120	1100	320	15.8	0.6	7.17
UB630K	320	645	223	17	37	162	1000	480	28.1	0.6	9.27
UB710K	375	714	278	22	36	144	900	550	38.9	0.6	11.10

※最高回転数は空気圧0.6MPa、標準ソフトジョー使用時の数値です。エアサプライリングは必ず固定して、チャックを回転させて下さい。
 ※爪1個の締付力は、把握力の1/3となります。 ※標準付属品：ソフトジョー、エアプレッシャゲージ。
 ※コレットパッド（オプション）使用で上記最小把握径よりも更に小径の把握が可能です。

■ AVF-3-FL型エア手動切換弁（特別付属品）

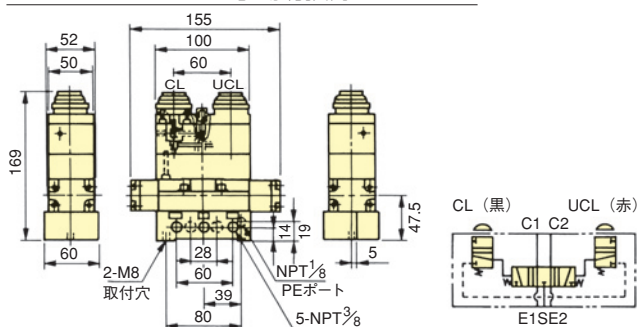

軽量小型でプッシュボタン操作となっており、旋盤に取付けた時、シンプルな配管設計ができるよう考慮しております。本バルブは、エキゾーストセンタタイプでフロント中空エアチャック用に設計されています。

使用圧力	0~1MPa
耐圧力	1.5MPa
押ボタン操作力	4kg
接続口径	Rc3/8



CHUCK

Air-Operated Self Contained Chuck

UB series

Built-in Pneumatic Cylinder

Large chuck best suited for pipe processing



スタンダードチャック

- The jaw position can be detected
- Internal pressure can be detected
- *CE corresponding

Dimensional Drawings

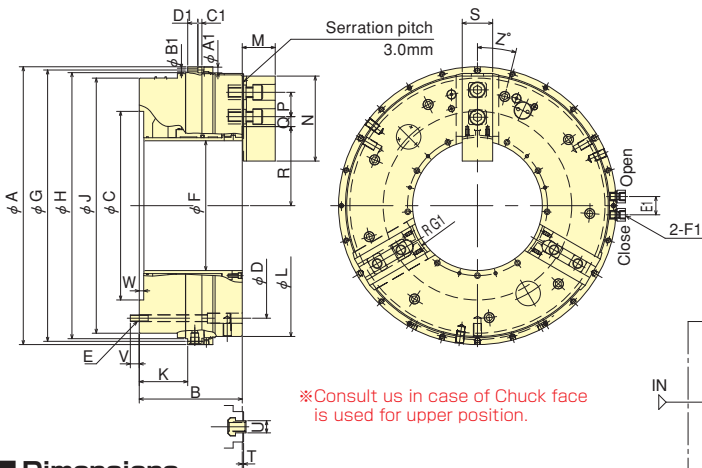

Recommended air circuit diagram

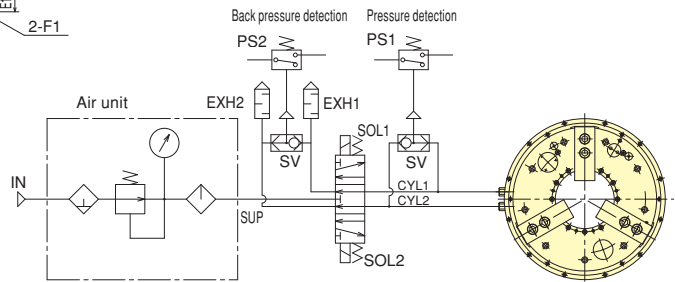

Dimensions

Model	A1	B1	C1	D1	E1	F1	G1
UB450K	11	6.6	6.6	25	45	Rc3/8	87.5
UB560K	14	9	9	20	45	Rc1/2	134
UB630K	14	9	10	25	45	Rc1/2	160
UB710K	17	11	11	33	45	Rc1/2	185

Model	A	B	C (H7)	D	E	F	G	H (H7)	J	K	L	M		N	P	Q max.	Q min.	R max.	R min.	S	T	U	V	W	Z
												mm	inch												
UB450K	494	212	275	373	9-M12	181	481	470	431	98.5	441	67.3	68.7	165	43	41.5	17.5	121.4	114.4	62	3.3	25.5	17	6	20
UB560K	626	230	375	485	6-M16	275	610	595	556	113.5	568	70.5	71.9	180	60	42	18	169	160.5	65	3.3	25.5	24	11	40
UB630K	698	254	465	555	9-M16	320	682	669	629	119.5	645	81.3	82.7	209.5	60	50.5	23.5	195	186.5	75	3.3	30	22	11	14
UB710K	790	252	520	620	9-M16	375	770	745	702	118.5	714	81.3	82.7	209.5	60	62.3	26.3	222.5	211.5	75	3.3	30	24	11	24

Specifications

*Gripping dia./gripping range is with standard soft jaws.

Model	Thru-Hole mm	Gripping range mm		Jaw Stroke (diameter) mm	Plunger Stroke mm	Max. Gripping Force kN	Max. Speed min ⁻¹	Net Weight with Soft top jaws kg	Moment of inertia kg·m ²	Max. pressure MPa	Air consumption per 10mm (at air pressure 0.6MPa) l
		Max.	Min.								
UB450K	181	441	117	14	40	100	1300	204	5.55	0.6	4.83
UB560K	275	568	215	17	37	120	1100	320	15.8	0.6	7.17
UB630K	320	645	223	17	37	162	1000	480	28.1	0.6	9.27
UB710K	375	714	278	22	36	144	900	550	38.9	0.6	11.10

*Maximum speed is shown with each value under air pressure of 0.6MPa, using standard soft jaw and fixed air supply ring.

*Gripping force of a jaw is one third of max. gripping force. *Standard accessories : Soft jaw, air pressure gauge, tools of a set.

*The work-pieces of diameter smaller than the above minimum gripping diameter can be gripped by using a collet pad (option).

AVF-3-FL type manual change valve (Special accessories)

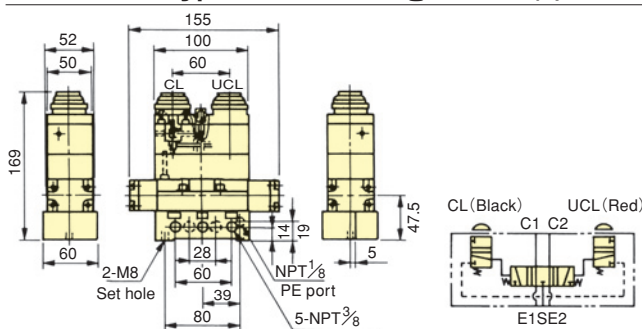

This valve is light-weight, compact and can be operated with the press of a button. The simple piping can be routed when the selector is mounted on the lathe. The valve is the exhaust centre type and designed for exclusive UB types.

Pressure	0~1MPa
Proof pressure	1.5MPa
Push button operation force	4kg
Connection bore	Rc3/8



CHUCK

シリンダ内蔵高速パワーチャック Cylinder built-in high-speed power chuck HRS series

マシニングセンタ系複合加工機に最適 Ideal for multi-tasking machining centres

- 機械側のロータリジョイントにより駆動する内蔵シリンダ
Built in cylinder operated by machine side rotary joint
- 薄型ボディが広い加工エリアを確保
The thin body provides wide machining area
- 3000min⁻¹の高速回転
High speed rotation capacity of 3000m⁻¹
- 把握精度0.01mmT.I.R.以下
High gripping accuracy of 0.01mmT.I.R.
- オプションのTナットプラスが使用可能
Optional Tnut-Plus can be used

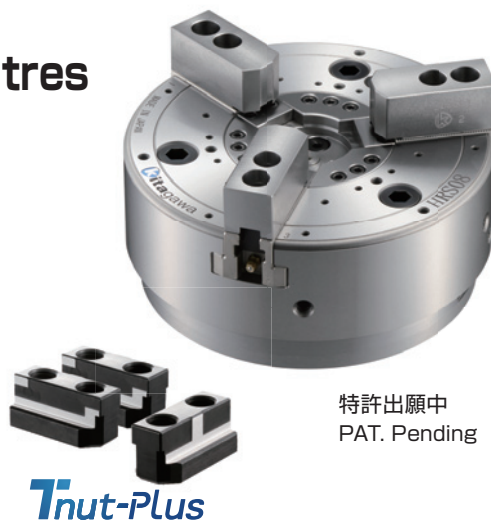

特許出願中
PAT. Pending

Tnut-Plus

■ 寸法図 Dimensional Drawings

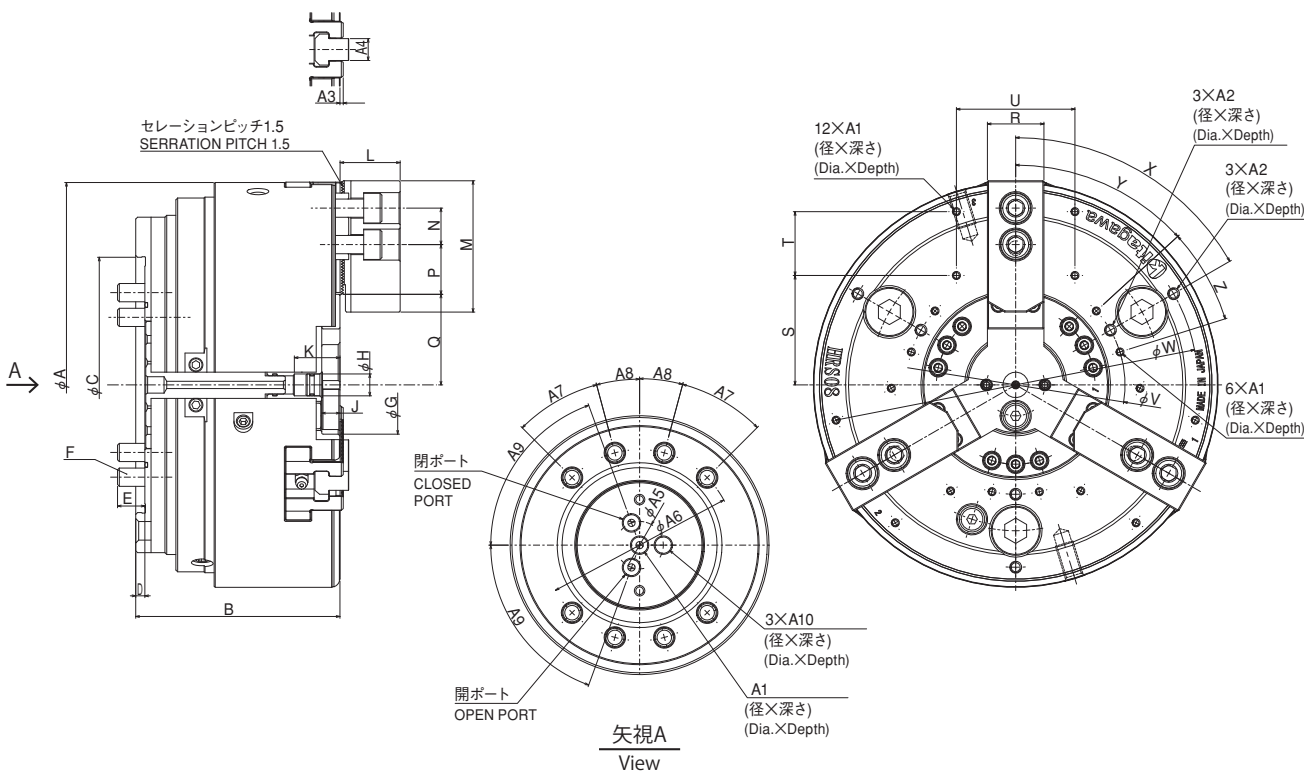

■ 寸法表 Dimensions

型式 Model	A	B	C (H6)	D	E	F	G (H8)	H	J	K	L	M	N	P max.	P min.	Q max.	Q min.
HRS08	222	112	140	5	15	8×M10	54	12	10.2	25.2	33	72	20	27.25	9.25	49.7	46.95

型式 Model	R	S	T	U	V	W	X	Y	Z	A1	A2	A3	A4	A5	A6	A7	A8	A9	A10
HRS08	31	60	35	65	120	200	60°	47.5°	25°	M4×8	M6×12	1.8	12	26	104.78	30°	15°	70°	φ9×10

■ 仕様表 Specifications

※許容最高回転速度は、実測値によります。※Max. speed is shown using actual test data.
※把握径/把握範囲は標準のソフトジョーを使用した場合。※Gripping dia./gripping range is with standard soft jaws.

型式 Model	把握径 Gripping range mm		ジョーストローク(直径) Jaw Stroke(diameter) mm	許容最高回転速度 Max. Speed min ⁻¹	最大静的把握力 Max. Gripping Force kN	最高回転時の動的把握力 Dynamic gripping force at max. speed kN	質量 Net Weight kg	慣性モーメント Moment of inertia kg·m ²	許容最大油圧 Max. pressure MPa	標準ソフトジョー Matching Soft top jaw
	Max.	Min.								
HRS08	222	45	5.5	3000	38.3	23.4	28.8	0.18	5.0	SJ06B1

把握力性能曲線 Gripping Characteristic Graphs

※トップジョーの質量モーメントごとの把握力と回転速度の関係です。
※Gripping force curves by top jaw's moment of inertia.

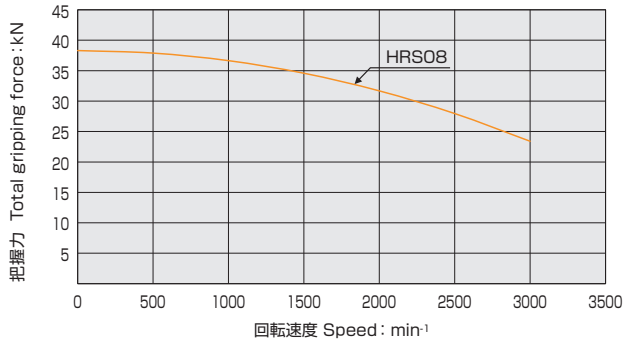

■ オプション Option

切削水や切り粉がチャック本体へ侵入するのを防ぎます。
Prevents cutting water and chips from entering the chuck body.

チャック本体の清掃が容易になります。
Cleaning of the chuck body becomes easier.



HRS08にオプション部品を取り付けた状態
Optional parts installed on HRS08.

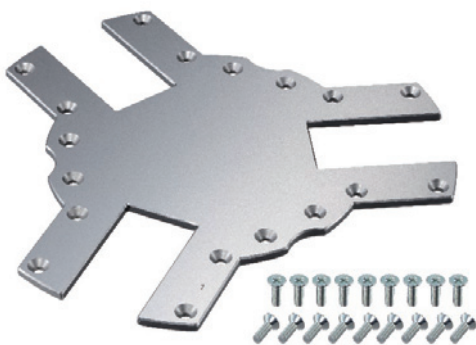

切り粉よけカバー
Chip protection cover



スライドシール付きソフトジョー
Soft jaw with slide seal

3個/1セット
3P/1set

スライドシールと専用ソフトジョーは別売です。
Slide seal and special soft jaw are sold separately.

専用ソフトジョーを使用してください。(標準ソフトジョー-SJ06B1にスライドシールは
取り付けませんのでご注意ください。)

Please use the special soft jaws. (Please note that the slide seal cannot be attached to
the standard soft jaw SJ06B1.)



CHUCK

精密中実エアチャック High Precision Air Chuck KPC series



ミクロン台の繰り返し精度 High Repeatability

仕上げ、精密加工に最適

Optimum KPC chuck for finishing and precision processes

●エアシリンダ内蔵 Built-in Pneumatic Cylinder

■ 寸法表 Dimensions

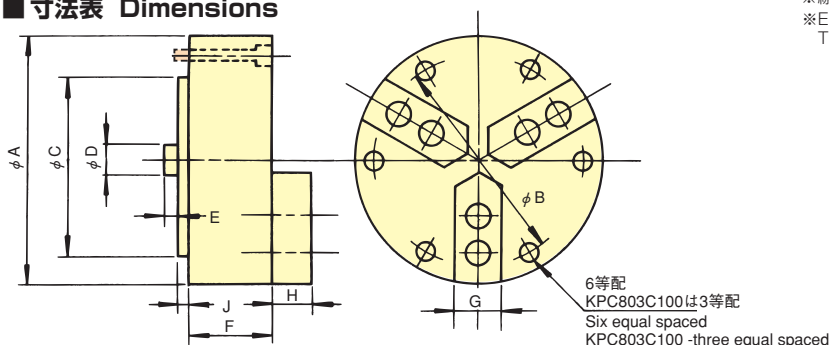

■ 寸法表 Dimensions

型式 Model	A	B	C (h6)	D	E max.	E min.	F	G	H	J	ジョー締付ボルト 本数×サイズ Jaw Mounting bolts	チャック取付ボルト 本数×サイズ Mounting bolts
KPC803C100	80	70	60	20.6	17	9.9	55	20	19	2	3-M5×16	3-M5×60
KPC43C048	100	88.9	82.55	20.6	18.8	15.3	50.5	20	19	2	3×2-M5×16	6-M5×55
KPC43C100	100	88.9	82.55	20.6	18	10.8	55	20	19	2	3×2-M5×16	6-M5×60
KPC63C100	150	135.8	124.97	20.6	17.6	10.4	56	25	19	2	3×4-M5×16	6-M6×65

■ 仕様表 Specifications

型式 Model	仕様 Specifications	繰り返し精度 Repeatability mm	ジョーの数 Number of Jaws	ジョーストローク(直径) Jaw Stroke(diameter) mm	把握範囲 Gripping range		最大静的把握力kN (エア圧0.7MPa) Max. Gripping Force kN (Air pressure 0.7MPa)	許容最高回転速度 Max. Speed min ⁻¹	質量 Net weight kg	慣性モーメント Moment of inertia kg·m ²
					外径 mm external φ	内径 mm Internal φ				
KPC803C100P		0.0025	3	2.5	3~70	6~79	4.3	6000	1.7	0.001
KPC803C100EP		0.0013								
KPC803C100EP1		0.0010								
KPC43C048P		0.0025	3	1.2	4~87	6~99	7.6	6000	2.7	0.003
KPC43C048EP		0.0013								
KPC43C048EP1		0.0010								
KPC43C100P		0.0025	3	2.5	3~87	6~99	7.6	6000	2.7	0.003
KPC43C100EP		0.0013								
KPC43C100EP1		0.0010								
KPC63C100P		0.0025	3	2.5	3~135	6~149	11.6	4000	6.0	0.016
KPC63C100EP		0.0013								
KPC63C100EP1		0.0010								

■ エアフィードチューブ(オプション部品) Ordering length of air feed tube (option)

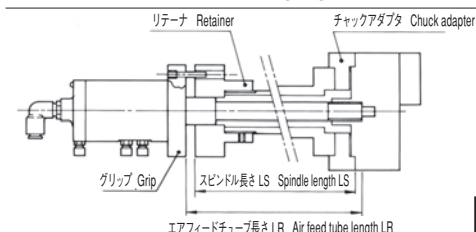

エアフィードチューブ(クーラントタイプ、ノンクーラントタイプ)をご注文頂きます場合は、図示の如くスピンドル長さLS又はエアフィードチューブ長さLRをご指示下さい。LSに対するLRは、LR=LS+15となります。(KPC43C048のみLR=LS+11) チャックアダプタ、リテーナはオプションです。

When ordering the air feed tube (coolant or non-coolant type), specify the spindle length LS as shown in the illustration. Air feed tube length LR is determined by LS E.G. LR = LS + 15 In case of KPC43C048: LR = LS + 11 Chuck Adaptor and Retainer are options

■ 標準型形状 Standard type jaw

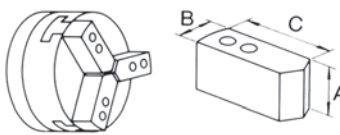

■ パイ型形状 Pie type jaw

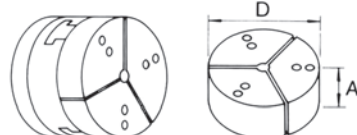

■ 標準型寸法表 Standard type jaw Dimensions

適合チャック Chuck	ジョー型式 Jaw model	材質 Material	寸法 Dimensions mm		
			A	B	C
KPC80 全機種 TYPE	KJ1A3-7	A L	19	20	38.4
	KJ1A3-15	A L	38	20	38.4
	KJ1A3-1	A L	25	20	38.4
	KJ1S3-7	S45C	19	20	38.4
	KJ1S3-15	S45C	38	20	38.4
	KJ1S3-1	S45C	25	20	38.4
KPC4 全機種 TYPE	KJ1A4-1	A L	25	20	48.4
	KJ1A4-2	A L	51	20	48.4
	KJ1A4-7	A L	19	20	48.4
	KJ1A4-15	A L	38	20	48.4
	KJ1S4-1	S45C	25	20	48.4
	KJ1S4-2	S45C	51	20	48.4
KPC6 全機種 TYPE	KJ1A6-1	A L	25	25	73.4
	KJ1A6-7	A L	19	25	73.4
	KJ1A6-15	A L	38	25	73.4
	KJ1S6-1	S45C	25	25	73.4
	KJ1S6-7	S45C	19	25	73.4
	KJ1S6-15	S45C	38	25	73.4

KJ1A※-7とKJ1S※-7は標準付属されています。 KJ1A※-7 and KJ1S※-7 are included as standard.

■ パイ型寸法表 Pie type jaw Dimensions

適合チャック Chuck	ジョー型式 Jaw model	材質 Material	寸法 Dimensions mm	
			A	D
KPC80 全機種 TYPE	KJ3A3-1	A L	25	80
	KJ3A3-15	A L	38	80
	KJ3S3-1	S45C	25	80
	KJ3S3-7	S45C	19	80
	KJ3S3-15	S45C	38	80
	KPC4 全機種 TYPE	KJ3A4-1	A L	25
KJ3A4-2		A L	51	100
KJ3A4-7		A L	19	100
KJ3A4-15		A L	38	100
KJ3S4-1		S45C	25	100
KJ3S4-2		S45C	51	100
KPC6 全機種 TYPE	KJ3S4-7	S45C	19	100
	KJ3S4-15	S45C	38	100
	KJ3A6-1	A L	25	150
	KJ3A6-15	A L	38	150
	KJ3S6-1	S45C	25	150
	KJ3S6-7	S45C	19	150



CHUCK

▶ P.43~P.64

アドバンスチャック
Advanced Chuck

アドバンスチャック Advanced Chuck

**量産加工機ラインでの多くの実績
専用ワーク対応
アドバンスチャックシリーズ**

**Exclusively designed work-pieces
specific chucks
for mass production**

あらゆるワークに対応し、量産加工機械用から特殊専用機械用、引込み把握からフェイスクランプなど、ぴったりの把握方法を選定し、安定性を発揮する技術をご提供します。

Designed with gripping to accommodate a variety of applications.



CHUCK

薄型デュアルロックチャック Thin dual lock chuck DLR series

薄型軽量なジョー平行移動引込チャック Parallel gripping and pull back chuck with low-profile and light-weight body



- ジョー平行移動後引込みの2段階把握
2 step gripping of parallel movement and pull down
- 慣性モーメントが小さいのでスピンドル加減速時間が短縮できる
Spindle acceleration time is reduced due to low moment of inertia
- 高把握精度0.01mm T.I.R.以下
High gripping accuracy of 0.01mm T.I.R. or less
- 歪みやすいワークの加工に最適
Ideal for machining easily distorted workpiece
- オプションのTnut-Plusを使用すると、ジョー脱着しても把握精度0.01mm T.I.R.以下となりジョー再成形不要
With optional Tnut-Plus maintaining a repeatability of 0.01mm T.I.R. or less after changing jaws
- 外径把握専用
Outer diameter gripping only

■ 把握動作 Gripping Sequence

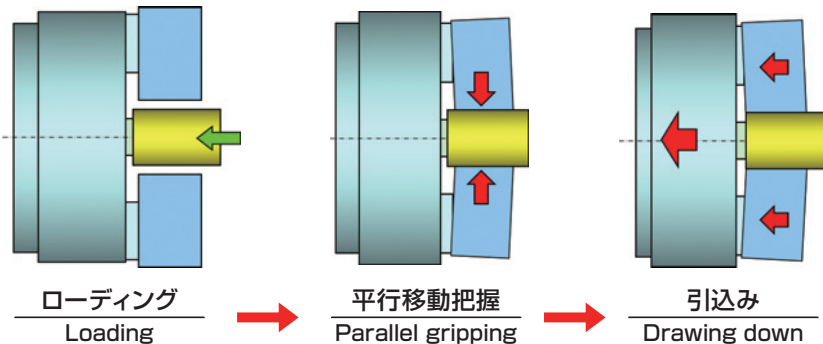

■ 把握例 Gripping example

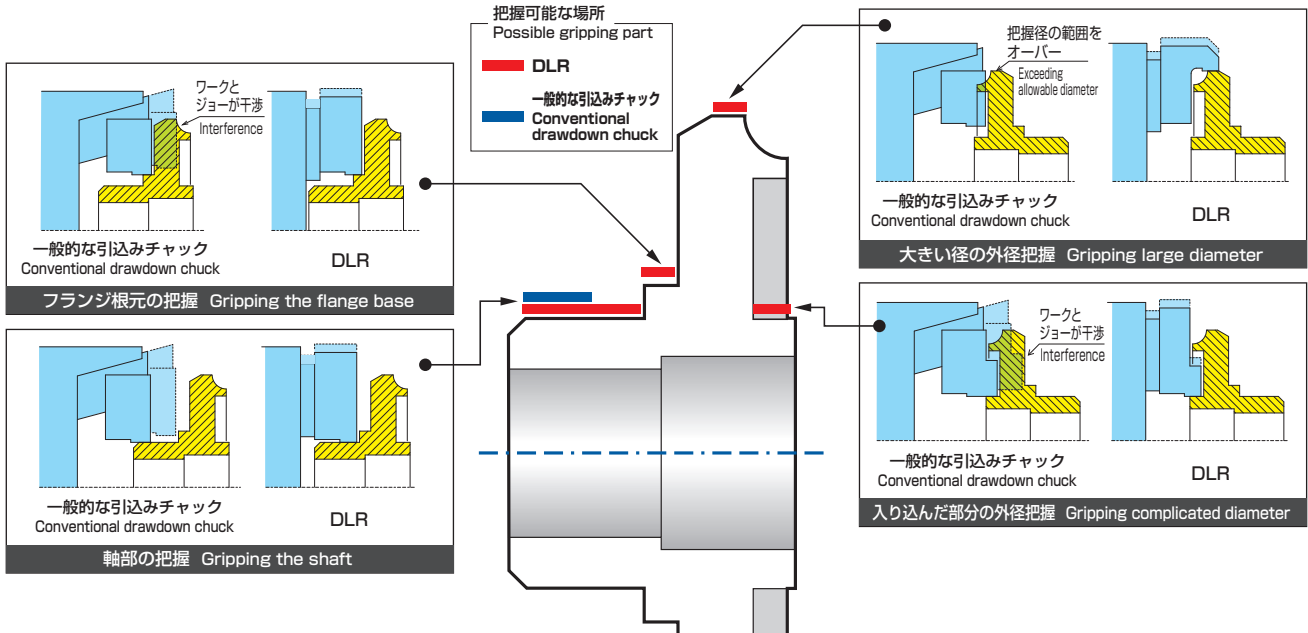

アドバンスチャック
Advanced Chuck

■ 寸法図 Dimensional Drawings

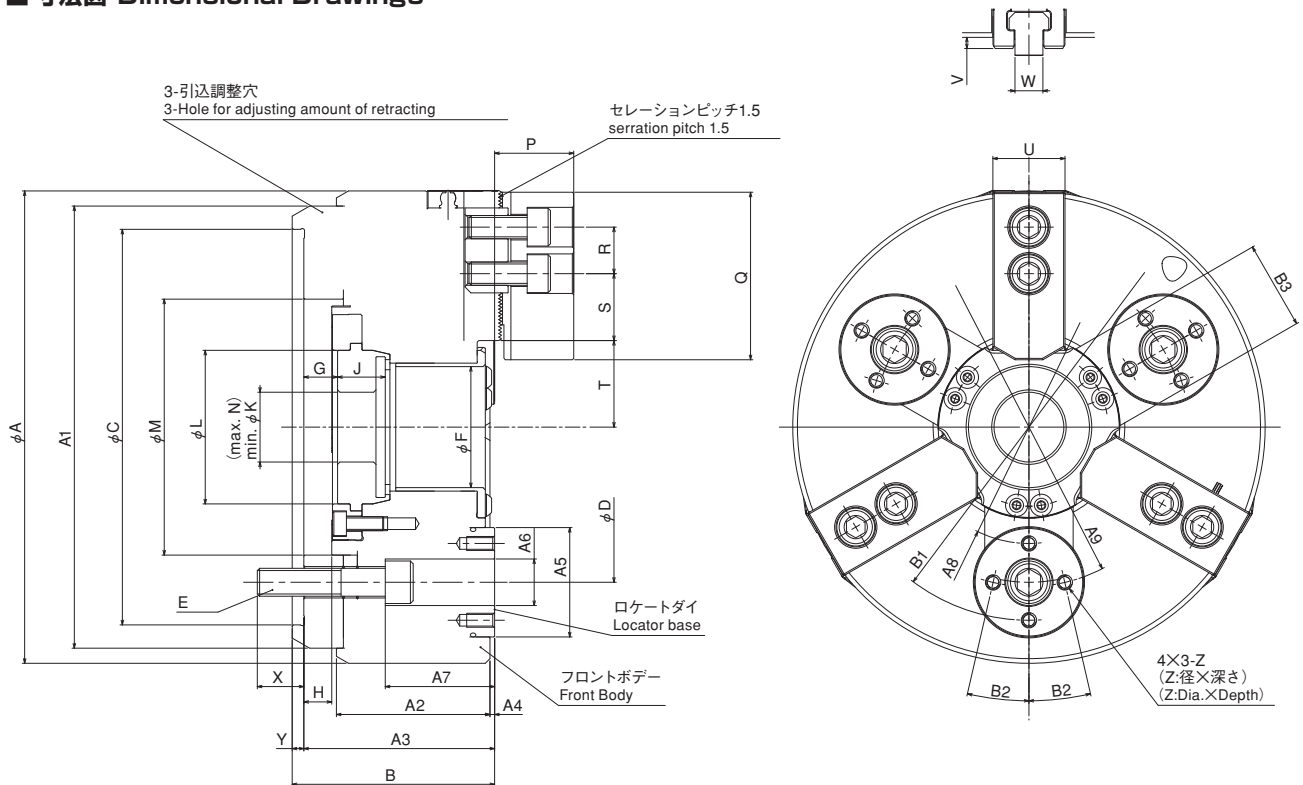

■ 寸法表 Dimensions

型式 Model	A	B	C (H6)	D	E	F	G max.	G min.	H max.	H min.	J	K	L	M	N	P	Q	R	S max.	S min.
DLRO8	203	87	170	133.35	3-M12	52	14.5	2.5	12	0	20.5	30	66	110	M60x2	34	72	20	28.75	9.25

型式 Model	T max.	T min.	U	V	W	X	Y	Z	A1	A2	A3	A4	A5	A6	A7	A8	A9	B1	B2	B3
DLRO8	37.2	34.45	31	4.8	12	20	5	M6x12	190	66	82	2	47	20	47	100	137	166	13°	38

■ 仕様表 Specifications

※許容最高回転速度は、実測値によります。※Max. speed is shown using actual test data.
 ※把握径/把握範囲は標準のソフトジョーを使用した場合。※Gripping dia./gripping range is with standard soft jaws.

型式 Model	貫通穴径 Thru-Hole mm	把握径 Gripping range mm Max. Min.	ジョーストローク(値) Jaw Stroke(diameter) mm	プランジャストローク Plunger Stroke mm	許容最高回転速度 Max. Speed min ⁻¹	許容最大入力 Max. Draw bar Pul Force kN	最大静的把握力 Max. Gripping Force kN	最高回転時の動的把握力 Dynamic gripping force at max. speed kN	質量 Net Weight kg	慣性モーメント Moment of inertia kg·m ²	適合シリンダ Matching Cylinder	許容最大油圧力 Max. pressure MPa	標準ソフトジョー Matching Soft top jaw
DLRO8	52	203 19	5.5	12	5000	24	60	20	17.2	0.095	S1552 SS1452K SR1453C	1.86 1.98 2.41	SJ06B1

■ ご使用上の注意点

1. 外径把握専用です。
2. ワークは必ずロケータの端面に押し当てて把握してください。
3. ロケータはロケータダイの上面に取付けてください。
4. フロントボデーへの追加加工は禁止です。ロケータの取付にはロケータダイ上面のタップ穴を使用してください。
5. DLRチャックはワークに合わせて引き込みを調整して使用するチャックです。ワークが浮上らないように、またワークを引き込み過ぎないように適切な引き込み調整にご使用ください。

■ Precautions for operation

1. The chuck is dedicated for outer diameter gripping.
2. Attach a work-piece to a locator before gripping.
3. Attach the locator to the top of the locator base.
4. Additional machining to the front body is prohibited. Use the tapped holes on the top of the locator base to install the locator.
5. The chuck is designed with adjustable drawing down to accommodate various workpieces. Ensure the drawing down is properly adjusted to prevent the workpiece from lifting and to avoid over drawing down.



CHUCK

デュアルロックチャック

DL200 series

2段階把握

多彩な把握で思い通りの加工を



●多彩な把握で高い生産性を実現!

KITAGAWAが開発した2段階把握。ジョーが平行移動してワークを把握、そして引込んで着座します。従来のジョー引込みチャックのようにジョーがZ方向に飛び出さないためワークとの干渉がなく、狭い部分や入り組んだ部分の把握が可能です。また、把握径はチャック外径まで広く、内径把握仕様でも使用できます。把握場所を選ばない多彩な把握で、様々なワークに対応します。前後工程に合わせた柔軟な加工に対応し、生産性の向上に貢献します。

●量産加工に最適!

防塵、グリス密封構造で、耐久性に優れたチャックです。量産加工、自動化ライン導入に最適です。

●ジョー成形が簡単!

ジョーには、セレーションジョーを採用。お客様自身で簡単にジョー成形が可能です。変種変量生産にも適しています。

*CE対応品

把握状態例

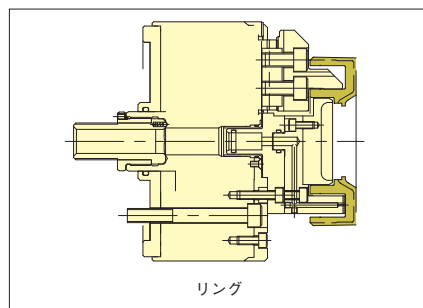

■ 把握例

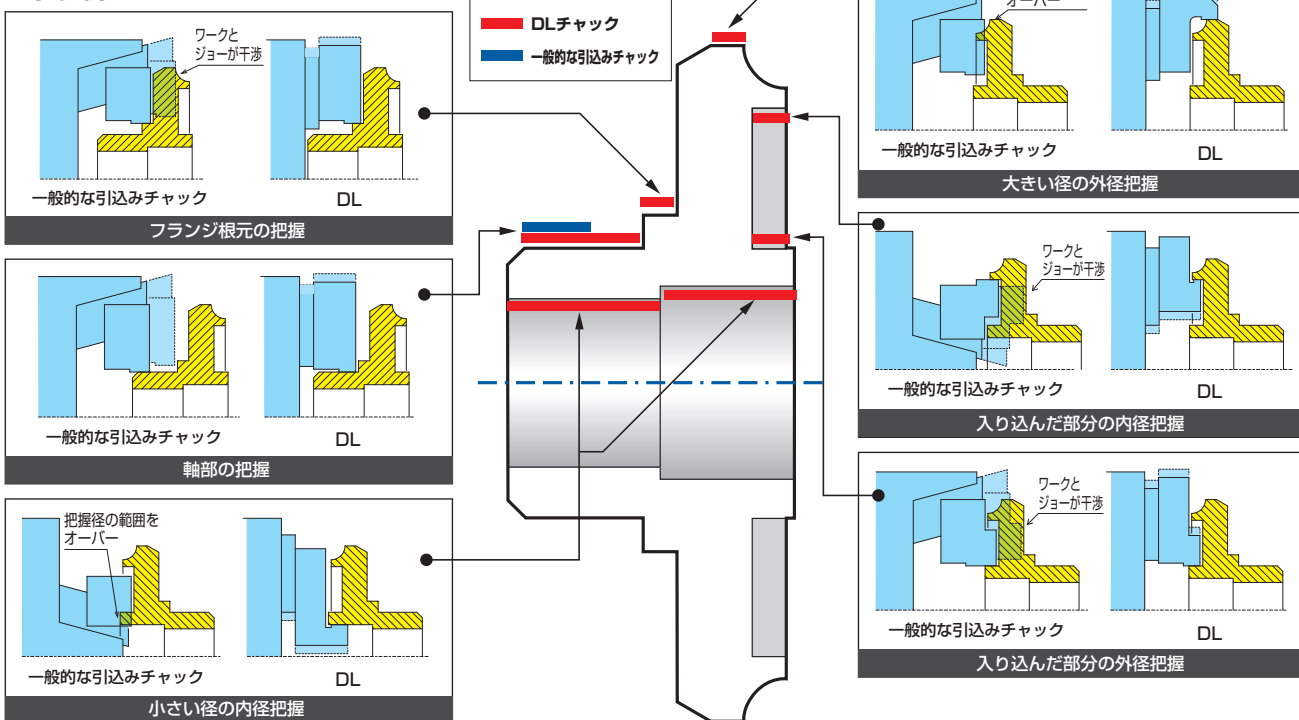

■ご使用上の注意

1. ワークは端面をロケータに当てて把握してください。
2. Tナットがマスタジョー端面から飛出した状態で使用しないでください。
3. 外径把握と内径把握を切替える場合、カバーを取外しマスタジョーを180°回転させる必要があります。
4. ワーク引込み量はワーク把握径、ジョーの剛性、ジョーの把握高さなど、把握する条件によって異なります。
引込みすぎてワークが歪んだり、引き込まなかったりする場合は、内部部品の調整、又は交換が必要になることがあります。その場合は弊社までご相談ください。
5. 安定した把握や、引込みを得るためには、ジョーを低くして使用してください。
6. チャック端面への追加加工はピン穴程度とし、カバーを貫通しないように注意してください。
7. DL206のロケータ取付用ねじはカバー取付用ねじを使用してください。
8. DL206・DL210にオプションジョーを使用する場合には、ジョーの追加加工が必要な場合があります。
9. DL210のオプションジョーは、12inch用のSJ12A1になります。ジョー形式の取違いに注意してください。
10. 把握位置からアングルランプ位置までのジョーストローク量(片側)は次の値以上確保してください。
DL206: 0.7mm, DL208: 0.8mm, DL210: 1mm, DL212: 1mm
11. その他、ご不明な点は弊社までご相談ください。

■ 寸法図

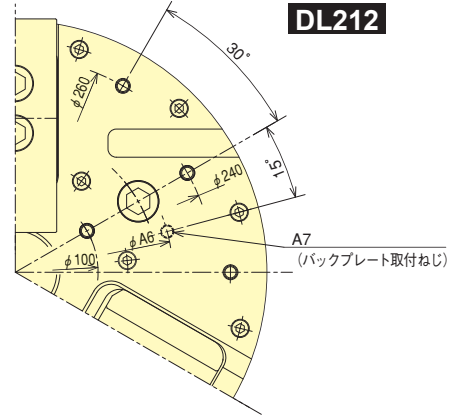
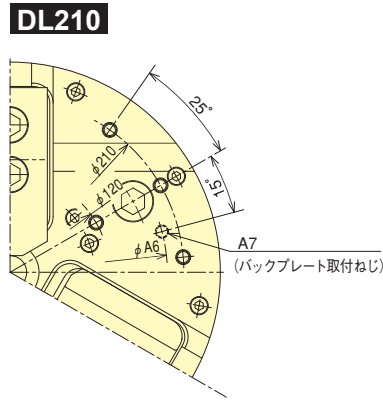
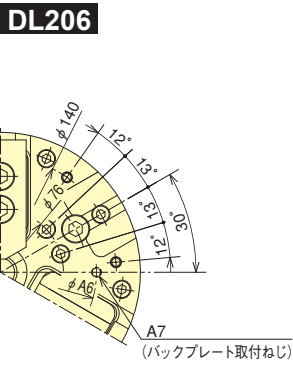
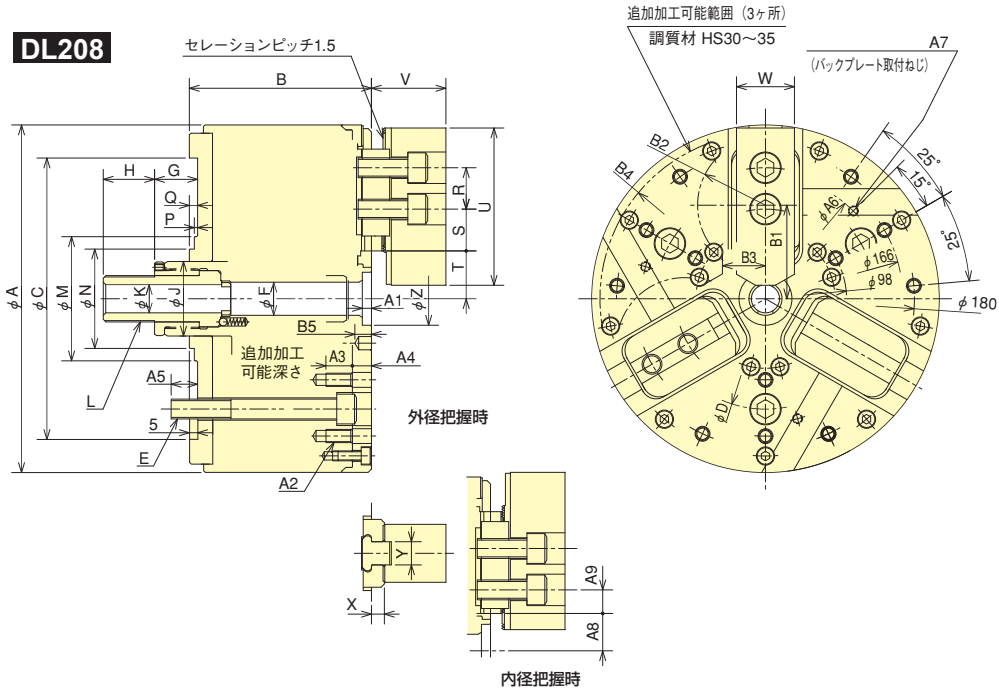

■ 寸法表

型式	A	B	C	D	E	F	G max.	G min.	H	J	K	L	M	N	P	Q	R	S max.	S min.	T max.	T min.
DL206	169	105	140	104.8	3-M10	20	34	22.5	30	42	17	M26×1.5	-	55	-	7	20	14.25	8.25	23.7	20.8
DL208	210	110	170	133.4	3-M12	20	37.5	26	31	45	17	M28×1.5	75	60	2	5	25	25.25	16.25	28.9	25.3
DL210	254	132	220	171.4	3-M16	20	38.5	24.5	39.5	50	17	M30×1.5	-	65	-	5	30	26.25	12.75	32.8	28.3
DL212	304	132	220	171.4	3-M16	50	33.5	19.5	44.5	75	17	M30×1.5	-	-	-	-	30	26.25	12.75	57.8	53.3

型式	U	V	W	X	Y	Z	A1	A2	A3	A4	A5	A6	A7	A8max.	A8min.	A9max.	A9min.	B1	B2	B3	B4	B5
DL206	72	41.5	31	10.3	12	32	4	3×7-M6	12	10.5	15	116	3-M6	23.7	20.8	21.25	15.25	47	R32	24	R79	MAX 9
DL208	95	45	35	7.8	14	32	5.5	3×4-M8	16	11.5	16	150	3-M6	26.2	22.6	20.25	11.25	56.5	R42	27	R100	MAX 10
DL210	101.5	59	45	14.7	18	35	5.5	3×4-M8	16	14	24	190	3-M8	29.7	25.2	35.25	21.75	68	R49	33	R120	MAX 12
DL212	129	64	50	14.7	18	50	14	3×4-M8	16	14	24	190	3-M8	54.7	50.2	35.25	21.75	93	R49	33	R145	MAX 12

■ 仕様表

型式	ジョーストローク (直径) mm	プランジャ ストローク mm	許容最大入力 kN		最大静的把握力 kN		許容最高 回転速度 min ⁻¹	質量 (標準ソフトジョー付) kg	慣性モーメント kg·m ²
			外径把握	内径把握	外径把握	内径把握			
DL206	5.8	11.5	19.0	12.6	54.0	36.0	6000	18.0	0.080
DL208	7.2	11.5	35.0	23.0	84.0	56.0	5000	30.0	0.135
DL210	9.0	14	50.0	33.0	110.0	73.3	4000	52.0	0.410
DL212	9.0	14	50.0	33.0	110.0	73.3	3000	74.0	0.880

型式	適合 シリンダ	許容最大油圧 MPa		標準ジョー 使用時把握範囲 mm	標準ジョー 形式	オプションジョー 使用時把握範囲 mm	オプション ジョー形式	使用最低入力 kN	使用最低油圧力 MPa
		外径把握	内径把握						
DL206	Y1020R/RE47	2.70	1.70	φ25~φ140	SJ06D1	φ25~φ158	SJ06B1	5.0	0.9
DL208	Y1225R/RE47	3.40	2.10	φ30~φ210	SJ08B1	-	-	6.2	0.8
DL210	Y1530R/RE47	3.40	2.30	φ40~φ234	SJ10D1	φ40~φ254	SJ12A1 (注9)	10.0	0.9
DL212	Y1530R/RE47	3.40	2.30	φ90~φ304	SJ12A1	-	-	10.0	0.9

アドバンスチャック
 Advanced Chuck



CHUCK

Dual Lock Chuck

DL200 series

2-step gripping

Unbelievable versatility with the ability to grip anything you want



● Increased gripping options

KITAGAWA introduce the worlds 1st chuck with two stage gripping action. Parallel jaw clamping with secondary pull back action for work-pieces seating. Jaws do not protrude in the Z Axis unlike conventional pull back chucks. This allows for improved gripping on difficult areas. The gripping range is extended up the chuck OD allowing a wider range of work-pieces to be machined. DL series contributes to improve the productivity by applying flexible chucking for various operations.

● Ideal for volume production machining

Dust proof sealed body design for long life. Suitable for automation and volume production.

● Easy jaw forming

Serrated Jaws are used allowing for easy jaw forming by customer.

*CE corresponding

Gripping Examples

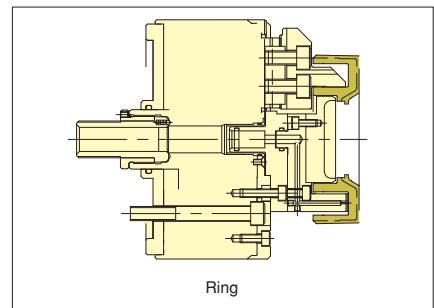

■ Example

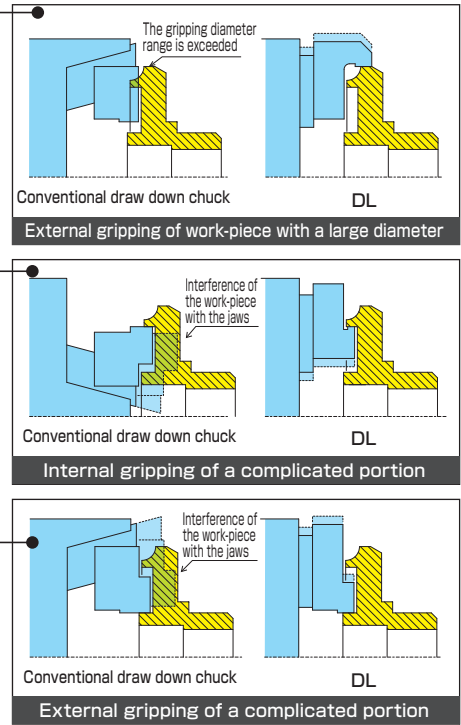
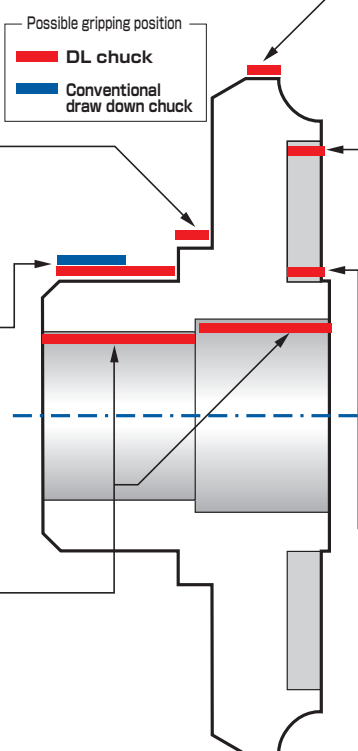
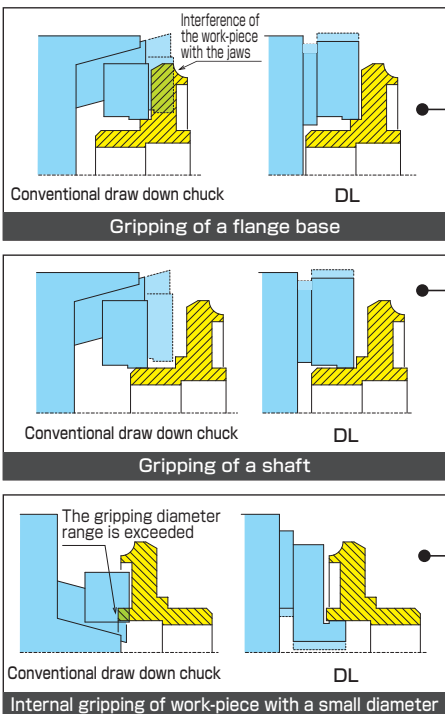

■ Precautions for operation

1. Attach a work-piece to a locator before gripping.
2. Do not use the chuck with a T-nut protruded from a master jaw end face.
3. When changing the method for gripping an inner diameter of the work-piece from an outer diameter of the work-piece, remove a cover in order to rotate the master jaw 180-degree.
4. A work-piece pulling quantity work-piece by gripping conditions such as the gripping diameter of the work-piece, stiffness of each jaw, jaw gripping height, etc. If the work-piece will be deformed due to over-pulling of the work-piece or vice versa, it is necessary to adjust parts or replace them. In this case, confer with our company.

5. To obtain a stable gripping and adequate pulling of the work-piece, set jaws low.
6. For additional machining to the chuck end face, a pin hole level is acceptable. Take care so as not to pass through the cover.
7. For locator mounting tap of DL206, use a cover mounting tap.
8. When using optional jaws for DL206 and DL210, the additional machining of jaws may be required.
9. Optional jaw of DL210 is SJ12A1 of 12-inch. Take care so as not to use a wrong type of the jaw.
10. Refer to the amounts below for Jaw Stroke (one side) from the gripping position to the unclamping position.
DL206 : 0.7mm, DL208 : 0.8mm, DL210 : 1mm, DL212 : 1mm
11. Confer with our company about other unclear points.

アドバンスドチャック
Advanced Chuck

Dimensional Drawings

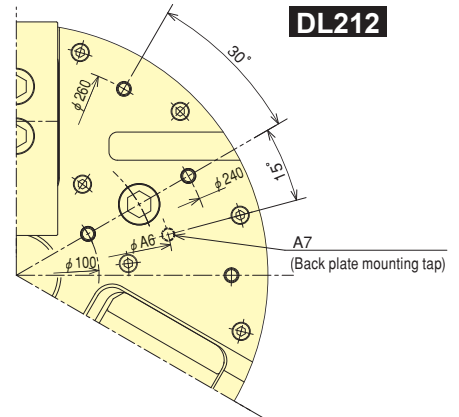
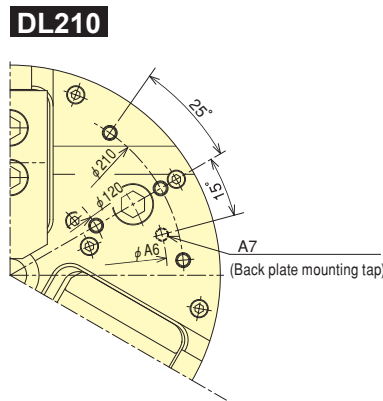
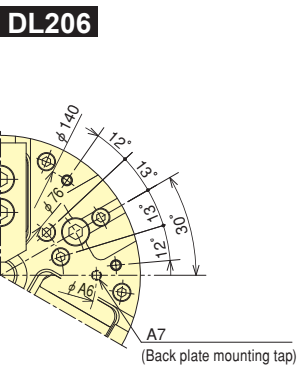
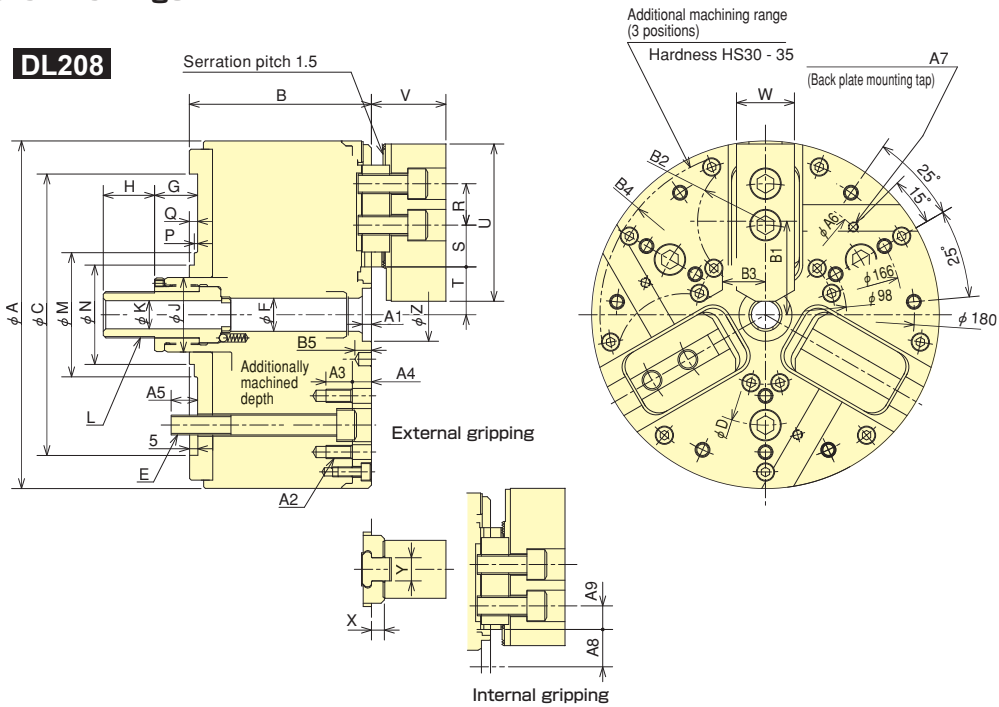

Dimensions

Model	A	B	C	D	E	F	G max.	G min.	H	J	K	L	M	N	P	Q	R	S max.	S min.	T max.	T min.
DL206	169	105	140	104.8	3-M10	20	34	22.5	30	42	17	M26×1.5	-	55	-	7	20	14.25	8.25	23.7	20.8
DL208	210	110	170	133.4	3-M12	20	37.5	26	31	45	17	M28×1.5	75	60	2	5	25	25.25	16.25	28.9	25.3
DL210	254	132	220	171.4	3-M16	20	38.5	24.5	39.5	50	17	M30×1.5	-	65	-	5	30	26.25	12.75	32.8	28.3
DL212	304	132	220	171.4	3-M16	50	33.5	19.5	44.5	75	17	M30×1.5	-	-	-	-	30	26.25	12.75	57.8	53.3

Model	U	V	W	X	Y	Z	A1	A2	A3	A4	A5	A6	A7	A8max.	A8min.	A9max.	A9min.	B1	B2	B3	B4	B5
DL206	72	41.5	31	10.3	12	32	4	3×7-M6	12	10.5	15	116	3-M6	23.7	20.8	21.25	15.25	47	R32	24	R79	MAX 9
DL208	95	45	35	7.8	14	32	5.5	3×4-M8	16	11.5	16	150	3-M6	26.2	22.6	20.25	11.25	56.5	R42	27	R100	MAX 10
DL210	101.5	59	45	14.7	18	35	5.5	3×4-M8	16	14	24	190	3-M8	29.7	25.2	35.25	21.75	68	R49	33	R120	MAX 12
DL212	129	64	50	14.7	18	50	14	3×4-M8	16	14	24	190	3-M8	54.7	50.2	35.25	21.75	93	R49	33	R145	MAX 12

Specifications

Model	Jaw Stroke (diameter) mm	Plunger Stroke mm	Max. Draw Bar Pull Force kN		Max. Gripping Force kN		Max. Speed min ⁻¹	Net Weight with Soft top jaws kg	Moment of inertia kg·m ²
			External gripping	Internal gripping	External gripping	Internal gripping			
DL206	5.8	11.5	19.0	12.6	54.0	36.0	6000	18.0	0.080
DL208	7.2	11.5	35.0	23.0	84.0	56.0	5000	30.0	0.135
DL210	9.0	14	50.0	33.0	110.0	73.3	4000	52.0	0.410
DL212	9.0	14	50.0	33.0	110.0	73.3	3000	74.0	0.880

Model	Matching Cylinder	Max. pressure MPa		Gripping range in standard jaw of use mm	Standard jaw type	Gripping range in optional jaw of use mm	Optional jaw type	Min. input kN	Min. pressure MPa
		External gripping	Internal gripping						
DL206	Y1020R/RE47	2.70	1.70	φ25~φ140	SJ06D1	φ25~φ158	SJ06B1	5.0	0.9
DL208	Y1225R/RE47	3.40	2.10	φ30~φ210	SJ08B1	-	-	6.2	0.8
DL210	Y1530R/RE47	3.40	2.30	φ40~φ234	SJ10D1	φ40~φ254	SJ12A1 (Note 9)	10.0	0.9
DL212	Y1530R/RE47	3.40	2.30	φ90~φ304	SJ12A1	-	-	10.0	0.9



CHUCK

パワーウイングチャック

PW(C) series

PW-C型はコンペイティング（心補償把握）仕様です。センタやピン穴基準で位置決めされたワークに倣って把握します。寸法やその他の仕様はPW型と同一です。

ワーク素材を引込む安定把握 しっかり掴んで荒加工に最適

●把握安定性が高く重切削が可能です

ワークをラジアル方向へ把握し、さらに強力な引きつけ作用でチャック端面に密着させますから把握が確実で安定しており重切削が可能です。

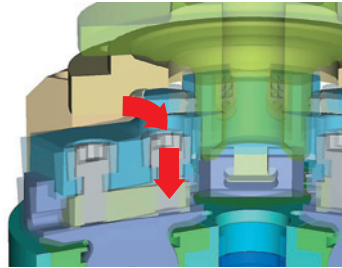

●長期間安定した把握力が得られます

マスタジョーが球体構造となっていますからシール性がよく長期間安定した把握力が得られます。

●左右のイコライズは最大5°まで可能です

ばらつきのあるワークにも左右5°ジョーがイコライズし安定把握します。

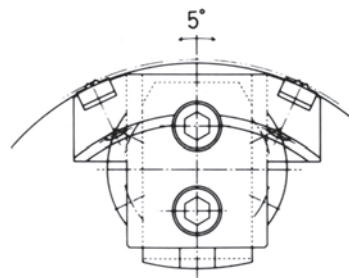

●最大テーパ20°までの把握が可能です

抜勾配のついた鋳造・鍛造品の黒皮面でもグリップピースで確実にテーパ部を把握します。

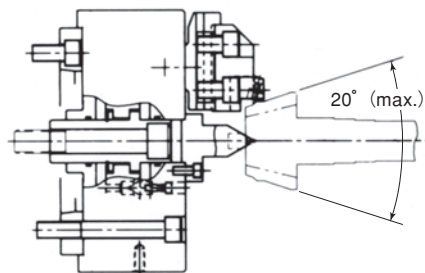

*CE対応品



●グリス密封性が大きく向上しました

シール（1）に加え、ボデーとリアボデーの合わせ面にもシール（2）を挿入することにより封入グリスの密封性を大きく向上させました。

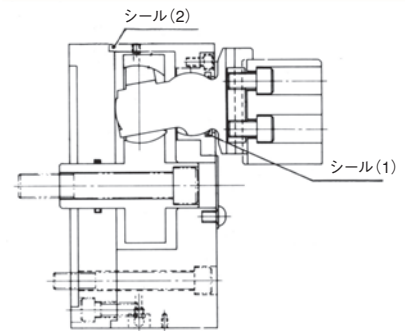

■グリップピースの種類

*グリップピースはワークの条件によってそれぞれ選定されます。

U-Type

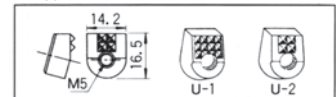

U-2S

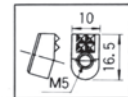

R-Type

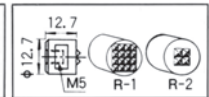

ワーク実績

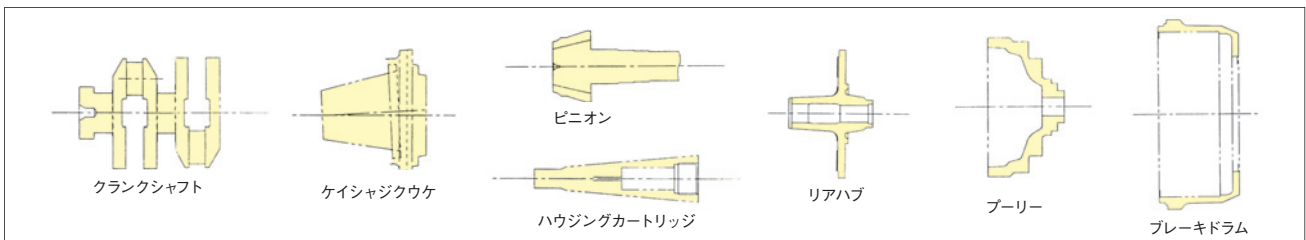

把握状態例

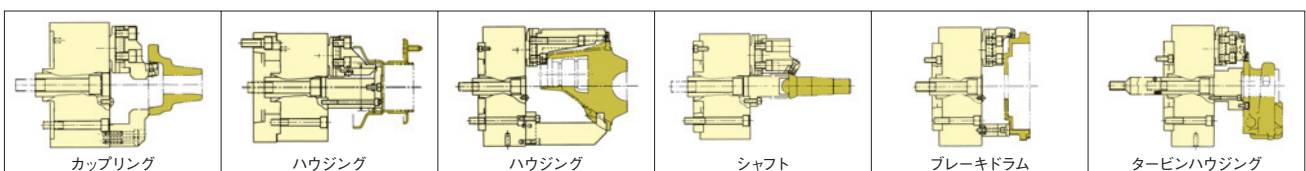

■ 寸法図

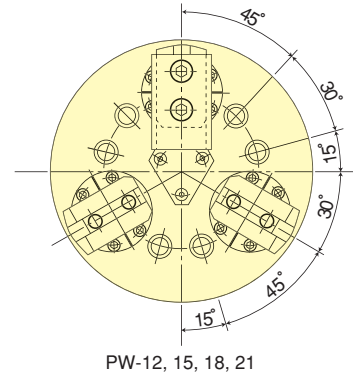
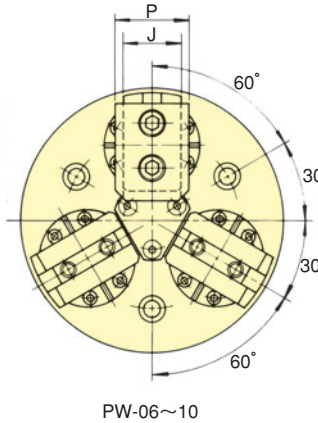
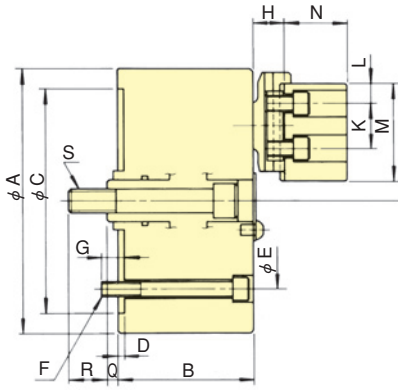

■ 寸法表

寸法	A	B	C(H6)	D	E	F	G	H	J
PW-06	162	77	140	5	104.8	3-M10	14	19.3	38.07
PW-08	200	88	170	5	133.4	3-M12	18	23.33	44.45
PW-10	254	105	220	5	171.4	3-M16	25	29.14	57.1
PW-12	300	105	220	5	171.4	6-M16	25	29.14	57.1
PW-15	381	117	300	5	235	6-M20	30	32.4	66.62
PW-18	450	117	300	5	235	6-M20	30	32.4	66.62
PW-21	533	118	380	6	300.2	6-M22	31	32.4	66.62

寸法	K	L	M	N	P	Q max.	Q min.	R	S
PW-06	29.36	15	67.5	47.7	50.8	24	12.6	25.4	M16
PW-08	34.14	15	74	54.17	57	29.3	15.1	29.2	M18
PW-10	44.45	19	89.5	66.9	70.1	34.9	17.4	34.7	M22
PW-12	44.45	19	108.5	66.9	70.1	34.9	17.4	34.7	M22
PW-15	53.98	23.9	140	73.2	76.2	48.7	26.3	41	M27
PW-18	53.98	23.9	140	73.2	76.2	48.7	26.3	41	M27
PW-21	53.98	23.9	140	73.2	76.2	47.7	25.3	41	M27

把握力性能曲線

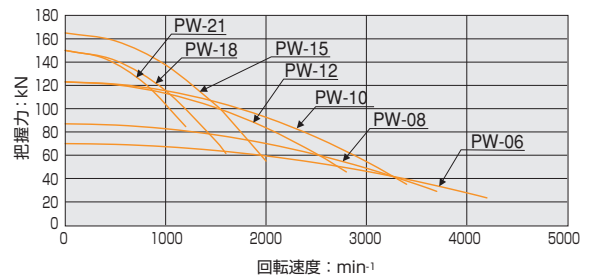

アドバンスドチャック
Advanced Chuck

■ 仕様表 ※把握径/把握範囲は標準のソフトジョーを使用した場合。

仕様	ジョー ストローク (直径) mm	フランジ ストローク mm	許容最大入力 kN	最大静的 把握力 kN	許容最高 回転速度 min ⁻¹	質量 (標準ソフトジョー付) kg	慣性モーメント kg·m ²	適合 シリンダ	許容最大 油圧力 MPa	把握範囲 外径 φmm	把握範囲 内径 φmm	偏心量 PWCのみ mm
PW-06	7.9	11.4	23.3	70.0	4200	14.7	0.050	Y1225R/RE47	2.30	13~120	70~160	1.0
PW-08	9.5	14.2	29.0	87.0	3700	23.5	0.110	Y1225R/RE47	2.84	35~152	76~194	1.5
PW-10	12.7	17.5	41.0	123.0	3400	39.3	0.265	Y1530R/RE47	2.80	54~203	94~235	2.0
PW-12	12.7	17.5	41.0	123.0	2800	58.3	0.523	Y1530R/RE47	2.80	58~241	129~300	2.0
PW-15	15.8	22.4	55.0	165.0	2000	95.0	1.943	Y2035R/RE	2.14	73~317	163~381	3.0
PW-18	15.8	22.4	55.0	150.0	1600	152	3.85	Y2035R/RE	2.14	154~386	225~450	3.0
PW-21	15.8	22.4	55.0	150.0	1200	195	7.06	Y2035R/RE	2.14	229~470	305~533	3.0

■ 作動位置寸法図 (外径把握時)

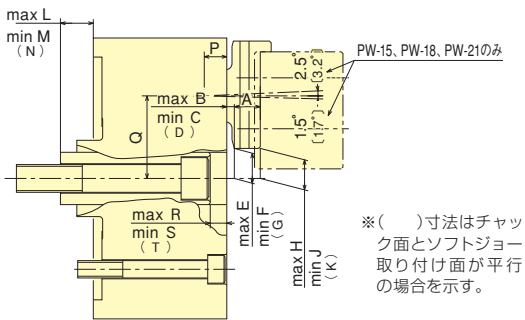

■ 作動位置寸法表 (外径把握時)

寸法	A	B	C	D	E	F	G	H	J	K
PW-06	15.50	5.02	3.05	3.80	20.09	18.89	19.33	20.77	18.48	19.33
PW-08	18.50	5.68	3.24	4.80	22.63	21.18	22.10	23.08	20.36	22.10
PW-10	25.61	5.47	2.44	3.53	31.16	29.44	30.03	32.37	28.77	30.03
PW-12	25.61	5.47	2.44	3.53	51.81	50.09	50.68	53.02	49.42	50.68
PW-15	28.67	6.27	2.35	3.73	75.85	73.76	74.45	77.45	72.91	74.45
PW-18	28.67	6.27	2.35	3.73	110.35	108.26	108.95	111.95	107.41	108.95
PW-21	28.67	6.27	2.35	3.73	152.05	149.96	150.65	153.65	149.11	150.65

■ 作動位置寸法図 (内径把握時)

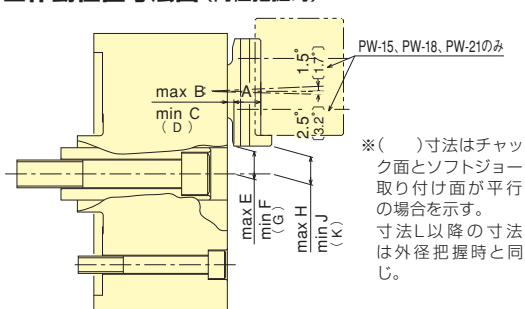

■ 作動位置寸法表 (内径把握時)

寸法	A	B	C	D	E	F	G	H	J	K
PW-06	15.03	5.66	3.43	4.27	16.32	15.08	15.53	17.25	14.52	15.53
PW-08	16.71	8.35	5.56	6.62	18.04	16.41	17.00	18.99	15.84	17.00
PW-10	20.51	10.92	7.23	8.63	19.59	17.61	18.33	20.74	16.92	18.33
PW-12	20.51	10.92	7.23	8.63	40.24	38.26	38.98	41.39	37.57	38.98
PW-15	23.94	12.19	6.44	8.46	54.75	52.23	53.05	56.41	51.35	53.05
PW-18	23.94	12.19	6.44	8.46	89.25	86.73	87.55	90.91	85.85	87.55
PW-21	23.94	12.19	6.44	8.46	130.95	128.43	129.25	132.61	127.55	129.25



CHUCK

Power Wing Chuck

PW(C) series

The specification for PW-C is the compensation chuck. The jaws will follow and grip the component held by Centre and Pin. The dimensions and specification are the same as those for PW.

Pull back of work-pieces for secure gripping of casting or forging

PWC compensating type for rough casting through centre



● Powerful Gripping

After gripping the component in a radial direction, a power PULL-BACK action is applied which significantly increases the Gripping Force, allowing a heavier machine cut to be taken.

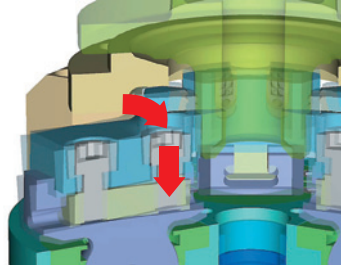

● High Durability

Master jaws are of spherical design and sealed against swarf and coolant. This permits High Gripping Forces to be retained between lubrication periods.

● Complete Sealing

Additional sealing at (1) and (2) reduces grease contamination and increases maintenance period.

● JAW Equalising 5° max equalising angle

Various work-pieces can be firmly gripped by the self-equalising jaws to max. 5°.

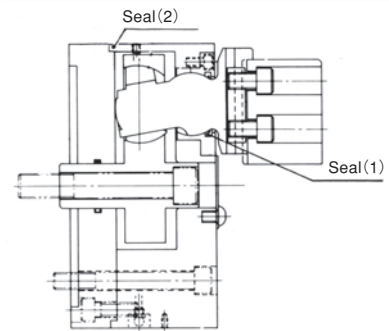
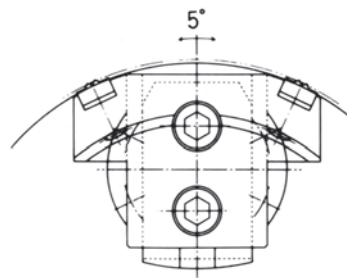

● Gripping on Tapered Parts

The radial and PULL-BACK jaw action allows rough tapered castings and forgings to be securely gripped to maximum 20°.

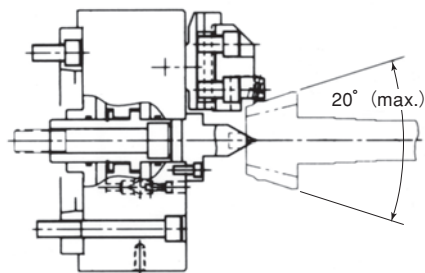

■ Type of the gripping pieces

*The type of the gripping pieces is selected according to the work-piece conditions.

U-Type

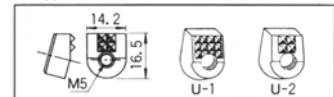

U-2S

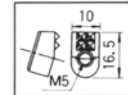

R-Type

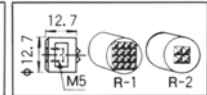

*CE corresponding

Work-piece Examples

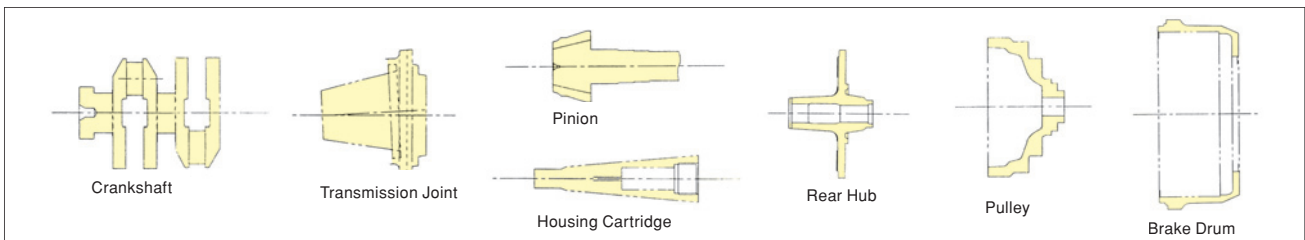

Gripping Examples

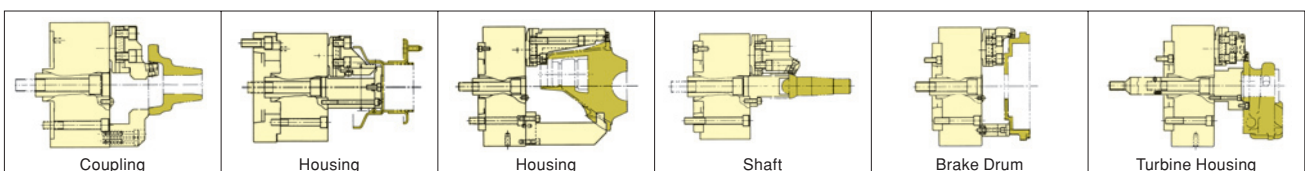

Dimensional Drawings

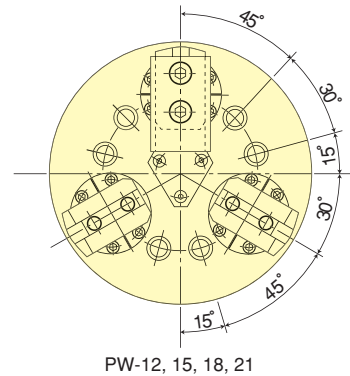
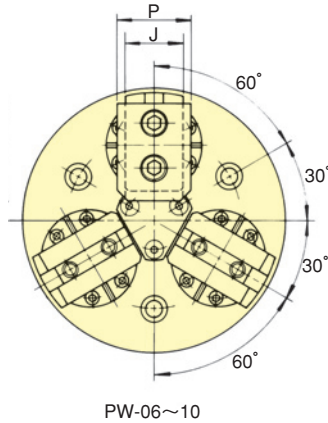
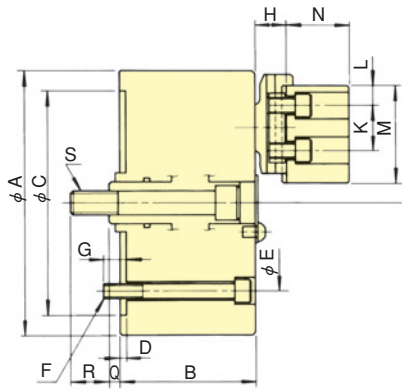

Dimensions

Dimensions	A	B	C (H6)	D	E	F	G	H	J
Model									
PW-06	162	77	140	5	104.8	3-M10	14	19.3	38.07
PW-08	200	88	170	5	133.4	3-M12	18	23.33	44.45
PW-10	254	105	220	5	171.4	3-M16	25	29.14	57.1
PW-12	300	105	220	5	171.4	6-M16	25	29.14	57.1
PW-15	381	117	300	5	235	6-M20	30	32.4	66.62
PW-18	450	117	300	5	235	6-M20	30	32.4	66.62
PW-21	533	118	380	6	300.2	6-M22	31	32.4	66.62

Dimensions	K	L	M	N	P	Q max.	Q min.	R	S
Model									
PW-06	29.36	15	67.5	47.7	50.8	24	12.6	25.4	M16
PW-08	34.14	15	74	54.17	57	29.3	15.1	29.2	M18
PW-10	44.45	19	89.5	66.9	70.1	34.9	17.4	34.7	M22
PW-12	44.45	19	108.5	66.9	70.1	34.9	17.4	34.7	M22
PW-15	53.98	23.9	140	73.2	76.2	48.7	26.3	41	M27
PW-18	53.98	23.9	140	73.2	76.2	48.7	26.3	41	M27
PW-21	53.98	23.9	140	73.2	76.2	47.7	25.3	41	M27

Gripping Performance

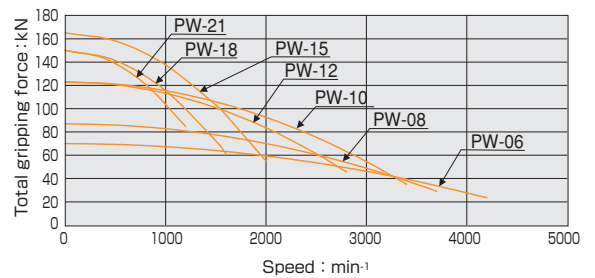

Specifications

Model	Specs	Jaw Stroke (diameter) mm	Plunger Stroke mm	Max. Draw Bar Pull Force kN	Max. Gripping Force kN	Max. Speed min ⁻¹	Net Weight with Soft top jaws kg	Moment of inertia kg·m ²	Matching Cylinder	Max. pressure MPa	Gripping range		Compensation value for PWC only mm
											external ϕ mm	internal ϕ mm	
PW-06		7.9	11.4	23.3	70.0	4200	14.7	0.050	Y1225R/RE47	2.30	13~120	70~160	1.0
PW-08		9.5	14.2	29.0	87.0	3700	23.5	0.110	Y1225R/RE47	2.84	35~152	76~194	1.5
PW-10		12.7	17.5	41.0	123.0	3400	39.3	0.265	Y1530R/RE47	2.80	54~203	94~235	2.0
PW-12		12.7	17.5	41.0	123.0	2800	58.3	0.523	Y1530R/RE47	2.80	58~241	129~300	2.0
PW-15		15.8	22.4	55.0	165.0	2000	95.0	1.943	Y2035R/RE	2.14	73~317	163~381	3.0
PW-18		15.8	22.4	55.0	150.0	1600	152	3.85	Y2035R/RE	2.14	154~386	225~450	3.0
PW-21		15.8	22.4	55.0	150.0	1200	195	7.06	Y2035R/RE	2.14	229~470	305~533	3.0

Dimensional Drawing for actuated position (External Gripping)

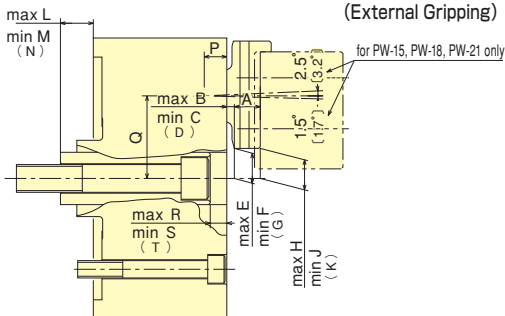

Dimensions for actuated position (External Gripping)

Dimensions	A	B	C	D	E	F	G	H	J	K
Model										
PW-06	15.50	5.02	3.05	3.80	20.09	18.89	19.33	20.77	18.48	19.33
PW-08	18.50	5.68	3.24	4.80	22.63	21.18	22.10	23.08	20.36	22.10
PW-10	25.61	5.47	2.44	3.53	31.16	29.44	30.03	32.37	28.77	30.03
PW-12	25.61	5.47	2.44	3.53	51.81	50.09	50.68	53.02	49.42	50.68
PW-15	28.67	6.27	2.35	3.73	75.85	73.76	74.45	77.45	72.91	74.45
PW-18	28.67	6.27	2.35	3.73	110.35	108.26	108.95	111.95	107.41	108.95
PW-21	28.67	6.27	2.35	3.73	152.05	149.96	150.65	153.65	149.11	150.65

Dimensional Drawing for actuated position (Internal Gripping)

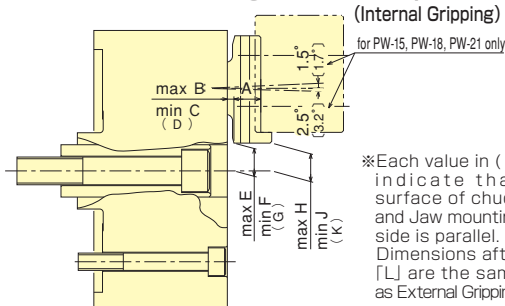

Dimensions for actuated position (Internal Gripping)

Dimensions	A	B	C	D	E	F	G	H	J	K
Model										
PW-06	15.03	5.66	3.43	4.27	16.32	15.08	15.53	17.25	14.52	15.53
PW-08	16.71	8.35	5.56	6.62	18.04	16.41	17.00	18.99	15.84	17.00
PW-10	20.51	10.92	7.23	8.63	19.59	17.61	18.33	20.74	16.92	18.33
PW-12	20.51	10.92	7.23	8.63	40.24	38.26	38.98	41.39	37.57	38.98
PW-15	23.94	12.19	6.44	8.46	54.75	52.23	53.05	56.41	51.35	53.05
PW-18	23.94	12.19	6.44	8.46	89.25	86.73	87.55	90.91	85.85	87.55
PW-21	23.94	12.19	6.44	8.46	130.95	128.43	129.25	132.61	127.55	129.25

※Each value in () indicate that surface of chuck and Jaw mounting side is parallel. Dimensions after [L] are the same as External Gripping.



CHUCK

2爪パワーウイングチャック 2-Jaw Power Wing Chuck PWT(C) series

PWT-C型はコンパセーティング(心補償把握)仕様です。センタやピン穴基準で位置決めされたワークに就って把握します。寸法やその他の仕様はPWT型と同一です。
PWC has the same specification as PW with the exception of the fact that PWC is a compensation type.

異形ワーク素材も引込み安定把握

Draw down irregular shaped materials for steady gripping

しっかり掴んで荒加工に最適

PWT(C) for gripping of square or flange castings or forgings



●異形物把握用の2爪タイプ

Two jaw type for gripping irregular work-pieces

3爪タイプ(PWシリーズ)では把握することの難しい角材・角フランジ等の異形物を安定把握します。

Draw down action ensures secure gripping of work-piece onto a reference surface.

●PWシリーズとソフトジョーの互換性があります

Compatible with PW series and soft jaws

*CE対応品 *CE corresponding

■寸法図 Dimensional Drawings

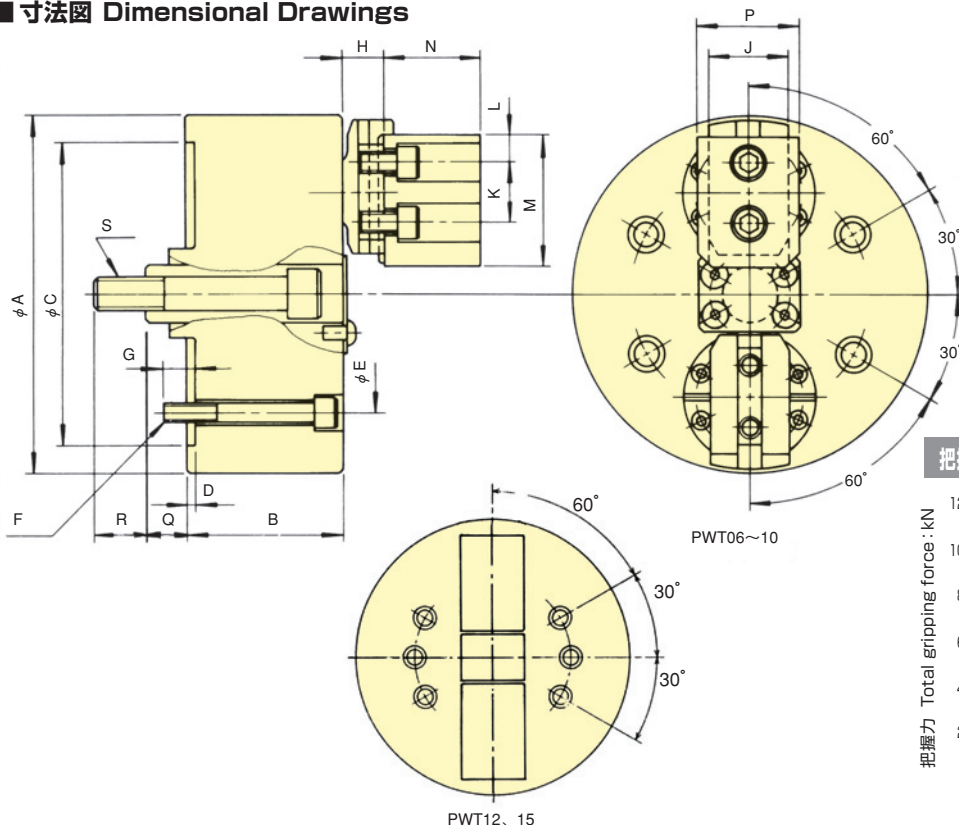

把握力性能曲線 Gripping Performance

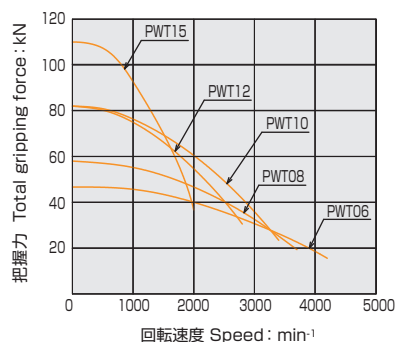

■寸法表 Dimensions

型式 Model	A	B	C(H6)	D	E	F	G	H	J	K	L	M	N	P	Q max.	Q min.	R	S
PWT06	162	77	140	5	104.8	4-M10	14	19.3	38.07	29.36	15	67.5	47.7	50.8	24	12.6	25.4	M16
PWT08	200	88	170	5	133.4	4-M12	18	23.33	44.45	34.14	15	74	54.17	57	29.3	15.1	29.2	M18
PWT10	254	105	220	5	171.4	4-M16	25	29.14	57.1	44.45	19	89.5	66.9	70.1	34.9	17.4	34.7	M22
PWT12	300	105	220	5	171.4	6-M16	25	29.14	57.1	44.45	19	108.5	66.9	70.1	34.9	17.4	34.7	M22
PWT15	381	117	300	5	235	6-M20	30	32.4	66.62	53.98	23.9	140	73.2	76.2	48.7	26.3	41	M27

■仕様表 Specifications ※把握径/把握範囲は標準のソフトジョーを使用した場合。*Gripping dia./gripping range is with standard soft jaws.

型式 Model	仕様 Specs		許容最大入力 Max. Draw Bar Pull Force kN	最大静的把握力 Max. Gripping Force kN	許容最高回転速度 Max. Speed min⁻¹	質量(標準ソフトジョー付) Net Weight with Soft top jaws kg	慣性モーメント Moment of inertia kg·m²	適合シリンダ Matching Cylinder	許容最大油圧力 Max. pressure MPa	把握範囲 Gripping range	
	ジョーストローク(直径) Jaw Stroke(diameter) mm	プランジャストローク Plunger Stroke mm								外径 external φ mm	内径 internal φ mm
PWT06	7.9	11.4	15.5	46.6	4200	14.0	0.047	Y1225R/RE47	1.60	22~120	70~160
PWT08	9.5	14.2	19.3	58.0	3700	24.0	0.120	Y1225R/RE47	1.98	43~152	76~194
PWT10	12.7	17.5	27.3	82.0	3400	46.0	0.378	Y1530R/RE47	1.85	66~203	94~235
PWT12	12.7	17.5	27.3	82.0	2800	63.0	0.720	Y1530R/RE47	1.82	71~241	129~300
PWT15	15.8	22.4	36.7	110.0	2000	112.0	2.130	Y2035R/RE47	1.40	89~317	163~381



CHUCK

中空プルロックチャック Open Centre Pull Lock Chuck PUB series

ワークを引込み高精度加工
Draw down for high-precision processing
シャフト加工にも対応する中空タイプ
Open Centre type accommodates shaft processing

*CE対応品 *CE corresponding

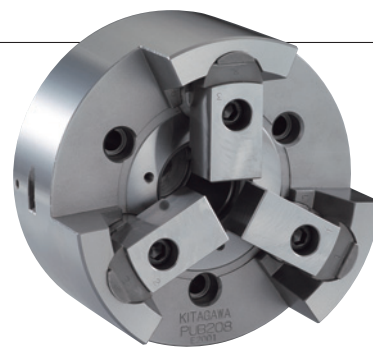

アドバンスチャック
Advanced Chuck

ワーク実績 Work-piece Examples

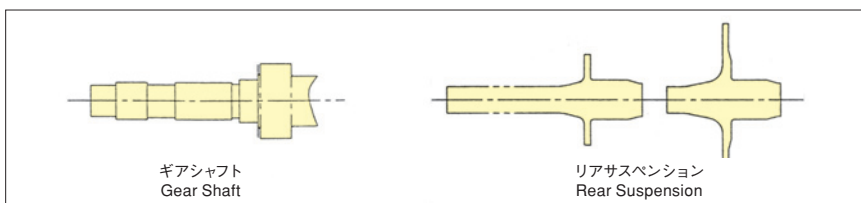

ギアシャフト
Gear Shaft

リアサスペンション
Rear Suspension

把握状態例 Gripping Examples

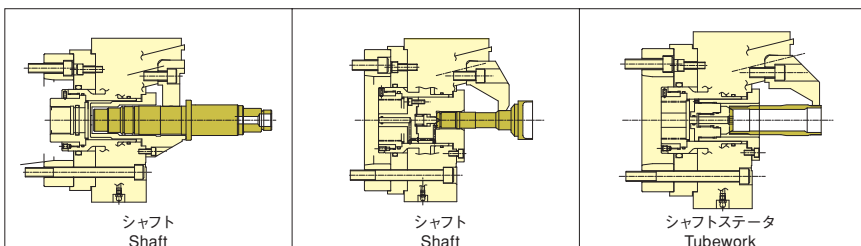

シャフト
Shaft

シャフト
Shaft

シャフトステータ
Tubework

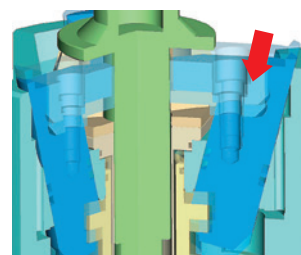
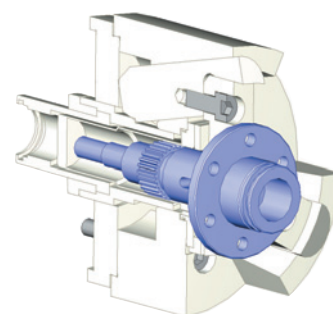

■ 寸法図 Dimensional Drawings

*部はPUB205では4mm
For PUB205, the * part is 4mm.

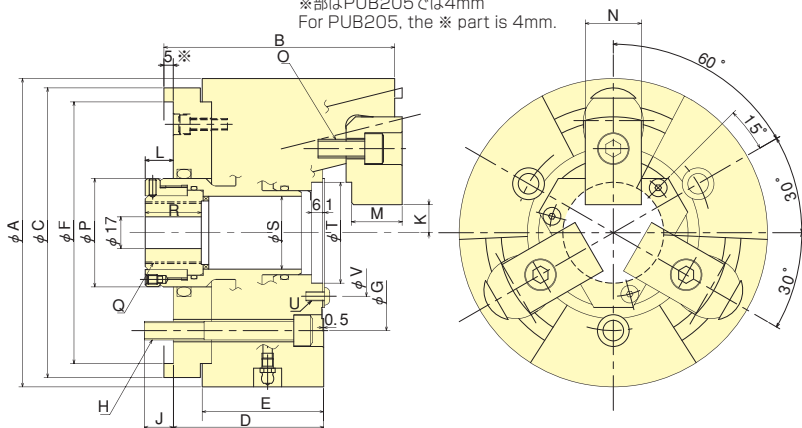

把握力性能曲線 Gripping Performance

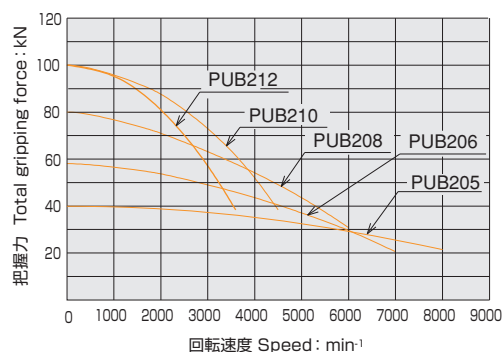

■ 寸法表 Dimensions

寸法 Dimensions 型式 Model	A	B	C	D	E	F (G7)	G	H	J	K max.	K min.	L max.	L min.	M	N	O	P	Q max.	R	S	T (H6)	U	V
PUB205	135	84.5	135	59	51	110	82.6	3-M10	15	13.25	11.75	7	1	17	24	3-M8	45	M36×1.5	25	31	-	3-M5	52
PUB206	165	123.5	155	80.5	65	140	104.8	3-M10	15.5	16.25	13.75	20	10	27	30	3-M10	58	M33×1.5	30	39	54	3-M5	68
PUB208	210	143	180	93	70	170	133.4	3-M12	17	16.25	13.75	20	10	31	35	3-M12	79	M45×2.0	29.5	50	66	3-M6	80
PUB210	254	158	230	103	82	220	171.4	3-M16	23	21.25	18.75	24	14	35	40	3-M14	102	M65×2.0	35.5	72	90	3-M8	104
PUB212	304	163	240	103	82	220	171.4	3-M16	25	46.25	43.75	19	9	40	40	3-M14	135	M92×2.0	35.5	100	114	3-M10	130

■ 仕様表 Specifications *把握径/把握範囲は標準のソフトジョーを使用した場合。*Gripping dia./gripping range is with standard soft jaws.

仕様 Specs 型式 Model	把握径 Gripping range		ジョーstroke(個) Jaw Stroke (diameter) mm	プランジャーストローク Plunger Stroke mm	許容最大入力 Max. Draw Bar Pull Force kN	最大静的把握力 Max. Gripping Force kN	許容最高 回転速度 Max. Speed min ⁻¹	質量(標準ソフトジョー付) Net Weight with Soft top jaws kg	慣性モーメント Moment of inertia kg·m ²	適合シリンダ Matching Cylinder	許容最大油圧力 Max. pressure MPa
	Max. mm	Min. mm									
PUB205	64	29	3	6	14	40	8000	6.5	0.016	F0933H	2.8
PUB206	69	35	5	10	18.0	58.0	7000	14.4	0.053	Y1020R/RE47	2.55
PUB208	89	35	5	10	25.0	80.0	6000	25.3	0.140	Y1225R/RE47	2.50
PUB210	112	47	5	10	35.0	100.0	4500	43.5	0.355	Y1225R/RE47	3.35
PUB212	162	99	5	10	35.0	100.0	3600	60.5	0.675	Y1225R/RE47	3.35



CHUCK

プルロックチャック

PU series

ワークを引込み高精度加工
抜群の安定精度で仕上げ加工に最適
オプションジョーの使用で把握範囲拡大

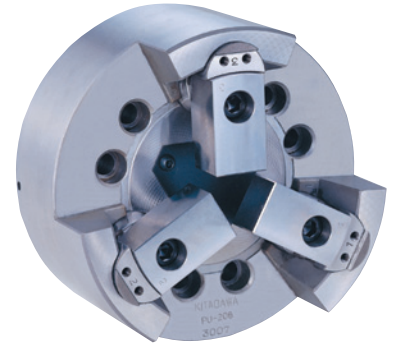

●把握安定性が高く重切削が可能です

ラジアル方向の把握と同時に強力な引きつけ作用でチャック基準面にワークを密着させ浮き上がりなく安定した重切削が可能です。

●繰り返し精度は抜群です

マスタジョーのスライド面をバックアップした構造になっていますから繰り返し使用しても高精度です。

●精度は長期間安定しています

洗練された構造と特殊鋼設計により、長期間安定した把握精度が保てます。

●自動化にも対応でき着座確認も採用可能です

*CE対応品

ワーク実績

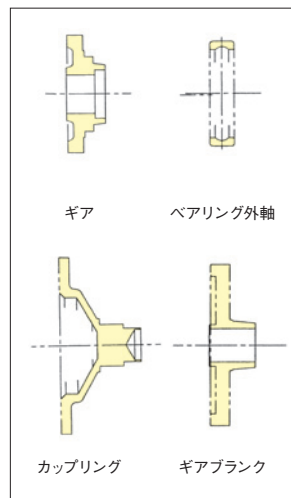

把握状態例

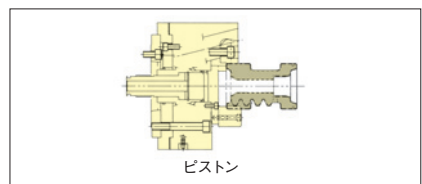

把握力性能曲線

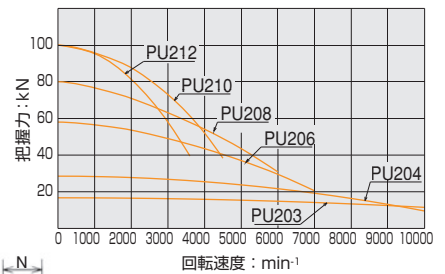

■寸法図

※PU203は3.5mm
PU204は4mm

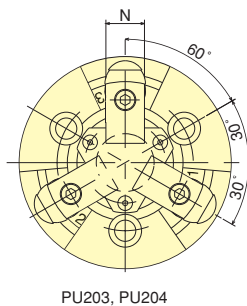
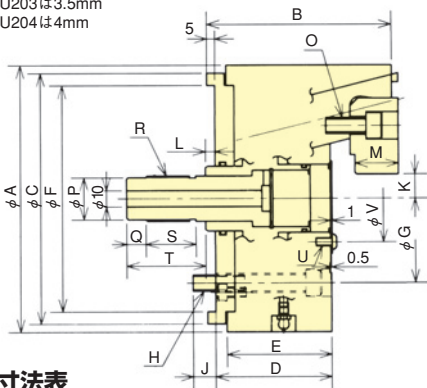

PU203, PU204

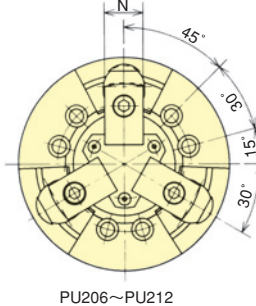

PU206~PU212

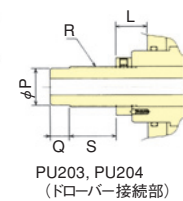

PU203, PU204 (ローバー接続部)

■寸法表

寸法	寸法																						
型式	A	B	C	D	E	F (G7)	G	H	J	K max.	K min.	L max.	L min.	M	N	O	P	Q	R	S	T	U	V
PU203	75	54.5	75	38.5	34	69	54	3-M6	9	2.5	1.5	21.5	17.5	9	15	3-M5	8	10	M10	19	-	3-M3	25.5
PU204	110	72.5	100	51	43	85	70.6	3-M10	12	10.75	9.25	19	13	14	20	3-M6	18	12	M20x1.5	24	-	3-M4	42
PU206	165	115	155	72	65	140	104.8	6-M10	14	16.25	13.75	11	1	27	30	3-M10	26	12	M28x1.5	31	49	3-M5	54
PU208	210	135	180	85	70	170	133.4	6-M12	15	16.25	13.75	11	1	31	35	3-M12	32	15	M35x1.5	30	51	3-M6	65
PU210	254	150	230	95	82	220	171.4	6-M16	23	21.25	18.75	12	2	35	40	3-M14	35	15	M38x1.5	30	51	3-M8	80
PU212	304	155	240	95	82	220	171.4	6-M16	23	46.25	43.75	12	2	40	40	3-M14	42	15	M45x1.5	30	51	3-M10	100

■仕様表

※PU204で8000min⁻¹を超えて使用の際はシリンダが特殊となりますので、別途打合せとさせていただきます。

※把握径/把握範囲は標準のソフトジョーを使用した場合。

仕様	把握径		ジョーストローク (直径) mm	プランジャ ストローク mm	許容最大入力 kN	最大静的把握力 kN	許容最高回転速度 min ⁻¹	質量 (標準ソフトジョー付) kg	慣性モーメント kg·m ²	適合シリンダ	許容最大油圧力 MPa
	Max. mm	Min. mm									
PU203	28	6	2	4	5.8	16.7	10000	1.5	0.0012	YG-329	1.63
PU204	50	24	3	6	10.0	28.5	8000 10000*	3.8	0.006	F0933H*	2.06
PU206	69	35	5	10	18.0	58.0	7000	14.1	0.050	Y1020R/RE47	2.55
PU208	89	35	5	10	25.0	80.0	6000	24.0	0.133	Y1225R/RE47	2.50
PU210	112	47	5	10	35.0	100.0	4500	42.0	0.338	Y1225R/RE47	3.35
PU212	162	99	5	10	35.0	100.0	3600	60.5	0.655	Y1225R/RE47	3.35



CHUCK

Pull Lock Chuck

PU series

Draw down for high-precision processing
Suitable gripping accuracy for finishing processes
Wide gripping range with the use of optional jaws

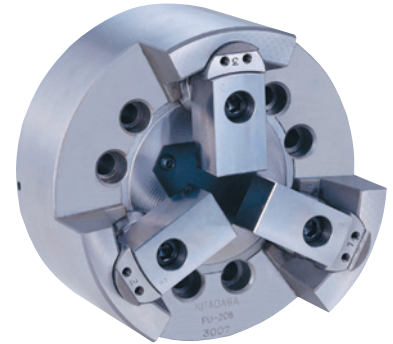

- High gripping stability means heavy cutting is possible

Radial gripping forces and strong pull back action allow stable heavy cutting.

- Excellent repeatability!

Side and rear support provided by the base jaws reduces the centrifugal gripping force loss thus resulting in high repeatability.

- Long-term stable accuracy!

The sophisticated mechanism and special steel design ensure longevity and gripping accuracy.

- Compatible with automation by use of seating confirmation

*CE corresponding

Work-piece Examples

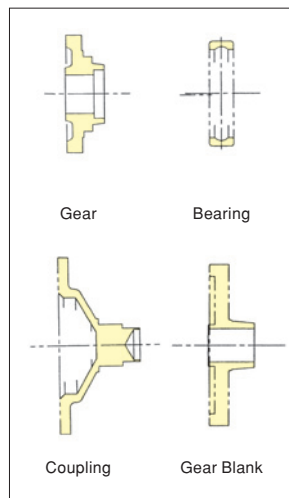

Gripping Examples

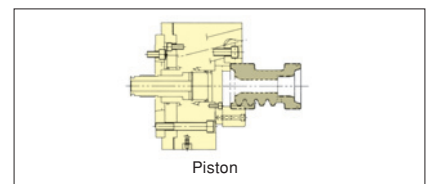

Gripping Performance

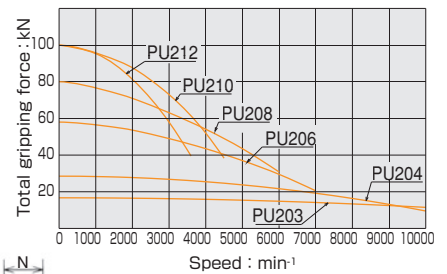

Dimensional Drawings

※PU203:3.5
PU204:4

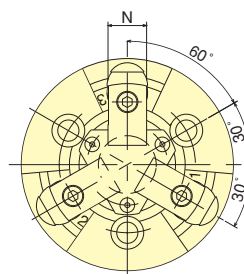
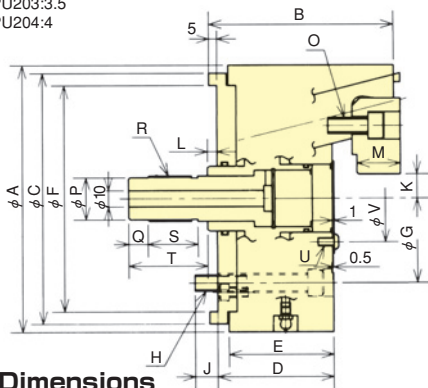

PU203, PU204

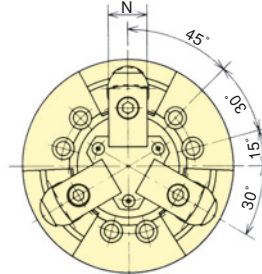

PU206~PU212

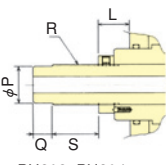

PU203, PU204 (Drawbar connection)

Dimensions

Model	A	B	C	D	E	F (G7)	G	H	J	K max.	K min.	L max.	L min.	M	N	O	P	Q	R	S	T	U	V
PU203	75	54.5	75	38.5	34	69	54	3-M6	9	2.5	1.5	21.5	17.5	9	15	3-M5	8	10	M10	19	-	3-M3	25.5
PU204	110	72.5	100	51	43	85	70.6	3-M10	12	10.75	9.25	19	13	14	20	3-M6	18	12	M20x1.5	24	-	3-M4	42
PU206	165	115	155	72	65	140	104.8	6-M10	14	16.25	13.75	11	1	27	30	3-M10	26	12	M28x1.5	31	49	3-M5	54
PU208	210	135	180	85	70	170	133.4	6-M12	15	16.25	13.75	11	1	31	35	3-M12	32	15	M35x1.5	30	51	3-M6	65
PU210	254	150	230	95	82	220	171.4	6-M16	23	21.25	18.75	12	2	35	40	3-M14	35	15	M38x1.5	30	51	3-M8	80
PU212	304	155	240	95	82	220	171.4	6-M16	23	46.25	43.75	12	2	40	40	3-M14	42	15	M45x1.5	30	51	3-M10	100

Specifications

※When using PU204 AT MORE THAN 8000min⁻¹, a special cylinder is required.

※Gripping dia./gripping range is with standard soft jaws.

Model	Gripping range		Jaw Stroke (diameter) mm	Plunger Stroke mm	Max. Draw Bar Pull Force kN	Max. Gripping Force kN	Max. Speed min ⁻¹	Net Weight with Soft top jaws kg	Moment of inertia kg·m ²	Matching Cylinder	Max. pressure MPa
Model	Max. mm	Min. mm									
PU203	28	6	2	4	5.8	16.7	10000	1.5	0.0012	YG-329	1.63
PU204	50	24	3	6	10.0	28.5	8000 10000*	3.8	0.006	F0933H*	2.06
PU206	69	35	5	10	18.0	58.0	7000	14.1	0.050	Y1020R/RE47	2.55
PU208	89	35	5	10	25.0	80.0	6000	24.0	0.133	Y1225R/RE47	2.50
PU210	112	47	5	10	35.0	100.0	4500	42.0	0.338	Y1225R/RE47	3.35
PU212	162	99	5	10	35.0	100.0	3600	60.5	0.655	Y1225R/RE47	3.35

アドバンスドチャック
Advanced Chuck



CHUCK

内径プルロックチャック Internal Pull Lock Chuck PUE series

ワーク内径を引込み把握

Pull back chuck for internal gripping

抜群の安定精度で仕上げ加工に最適

Draw down for high-precision processing

*CE対応品 *CE corresponding



オプションジョーの使用で把握範囲拡大

Wide gripping range with the use of optional jaw

ワーク実績 Work-piece Examples

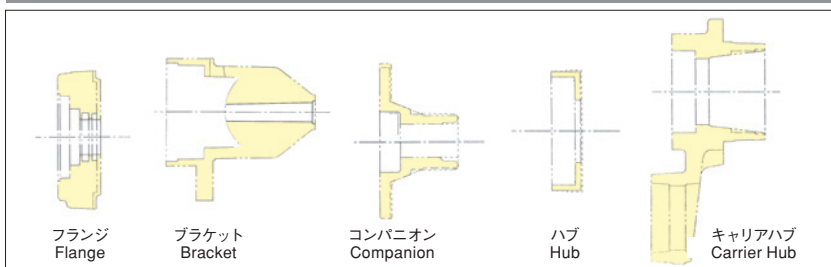

把握力性能曲線 Gripping Performance

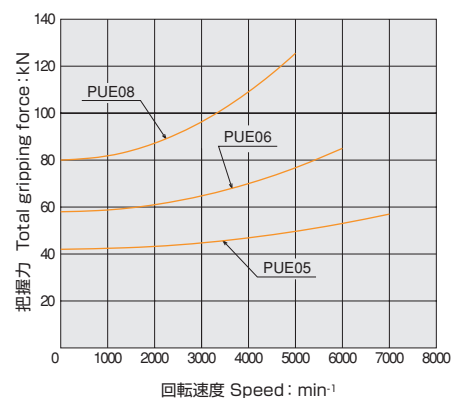

把握状態例 Gripping Examples

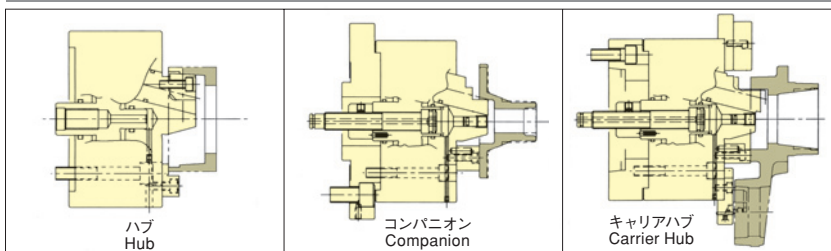

■ 寸法図 Dimensional Drawings

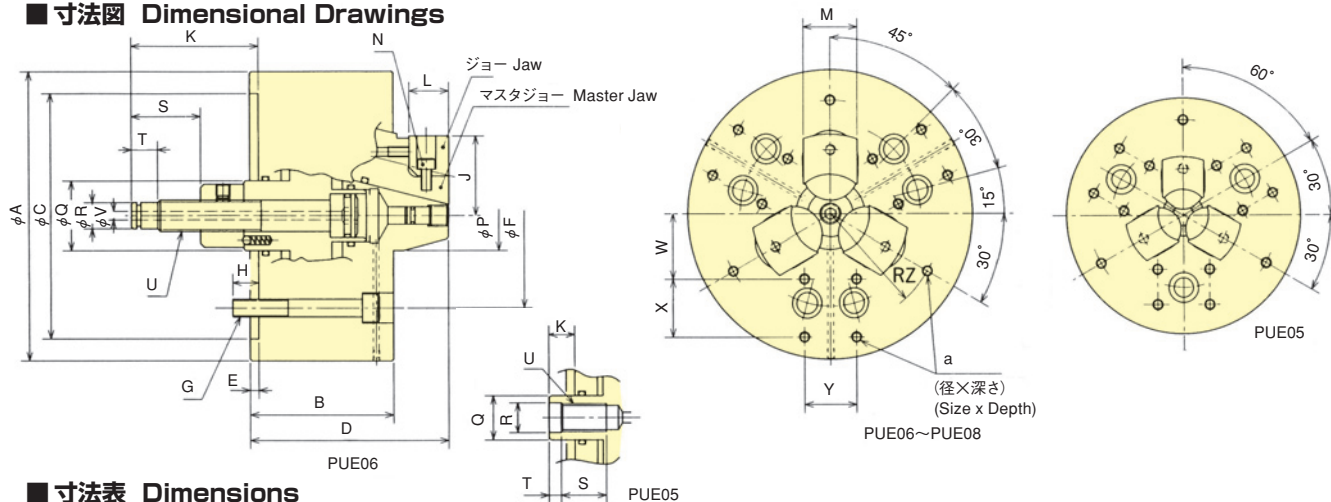

■ 寸法表 Dimensions

寸法 Dimensions 型式 Model	A	B	C(G7)	D	E	F	G	H	J max.	J min.	K max.	K min.	L	M	N	P	Q	R	S	T	U	V	W	X	Y	Z	a
PUE05	135	72	110	98	5	82.55	3-M10	15	34.4	33	18	12	20	24	3-M6	24	25	17 ^{±0.1}	26	7	M16x2	-	31	20	30	55	M6x11
PUE06	165	83	140	115	5	104.8	6-M10	15	46.9	44.5	78.8	68.5	23	31	3-M6	40	40	15h8	40	15	M18x25	5	37	33	30	65	M6x11
PUE08	210	94	170	139	5	133.4	6-M12	17	57.2	54.8	91.8	81.5	23	35	3-M6	49	40	15h8	47.5	15	M20	5	45	40	30	80	M6x11

■ 仕様表 Specifications

※PUE05で6000min⁻¹を越えて使用の際はシリンダが特殊となりますので、別途打合せとさせていただきます。
※When using PUE-05 at more than 6000min⁻¹, a special cylinder is required.

仕様 Specs 型式 Model	ジョーストローク (直径) Jaw Stroke (diameter) mm	プランジャストローク Plunger Stroke mm	許容最大入力 Max. Draw Bar Pull Force kN	最大静的把握力 Max. Gripping Force kN	許容最高回転速度 Max. Speed min ⁻¹	質量 (標準ソフトジョー付) Net Weight with Soft top jaws kg	慣性モーメント Moment of inertia kg·m ²	適合シリンダ Matching Cylinder	許容最大油圧力 Max. pressure MPa	把握範囲 Gripping range			
										標準ジョー Standard jaws	オプションジョー Option jaws	マスタジョー Master jaws	マスタジョー把握 Master jaws gripping
PUE05	2.8	6	13.0	42.0	7000	7.6	0.018	Y1020R/RE47 [※]	1.90	φ53~φ63	φ69~φ78	φ29~φ53	
PUE06	4.8	10.3	18.0	58.0	6000	13.9	0.043	Y1020R/RE47	2.50	φ70~φ87	φ89~φ108	φ44~φ70	
PUE08	4.8	10.3	24.8	80.0	5000	26.8	0.144	Y1020R/RE47	3.40	φ74~φ108	φ113~φ148	φ50~φ74	



CHUCK

レベルロックチャック Level Lock Chuck LU series

**低コストでも引込み把握
Economical pull back chuck**

**大きなジョーストロークでワーク搬入も容易に
Easy work-piece loading with long jaw stroke**

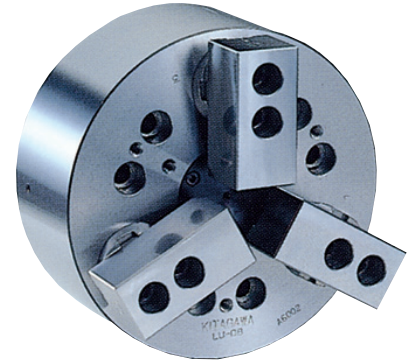

- 抜き勾配のある鋳物・鍛造品の把握が可能
Suitable for gripping castings and forgings with draft angle
- 大きなジョーストロークを実現 Long Jaw Stroke
- 安定した把握精度 Stable gripping accuracy

把握状態例 Gripping Examples

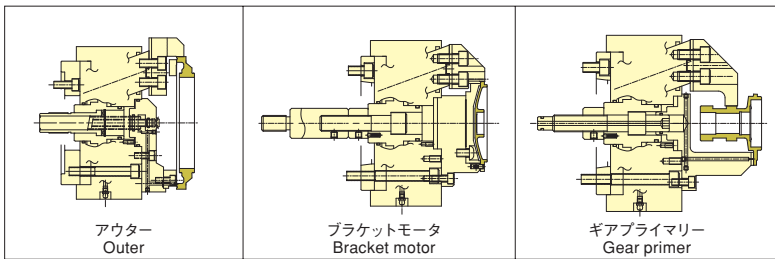

把握力性能曲線 Gripping Performance

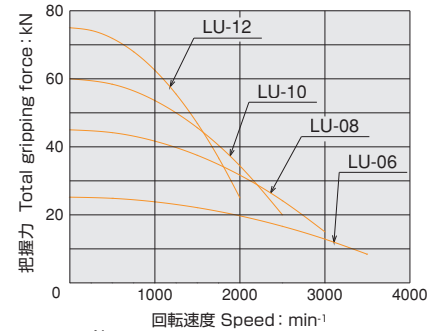

寸法図 Dimensional Drawings

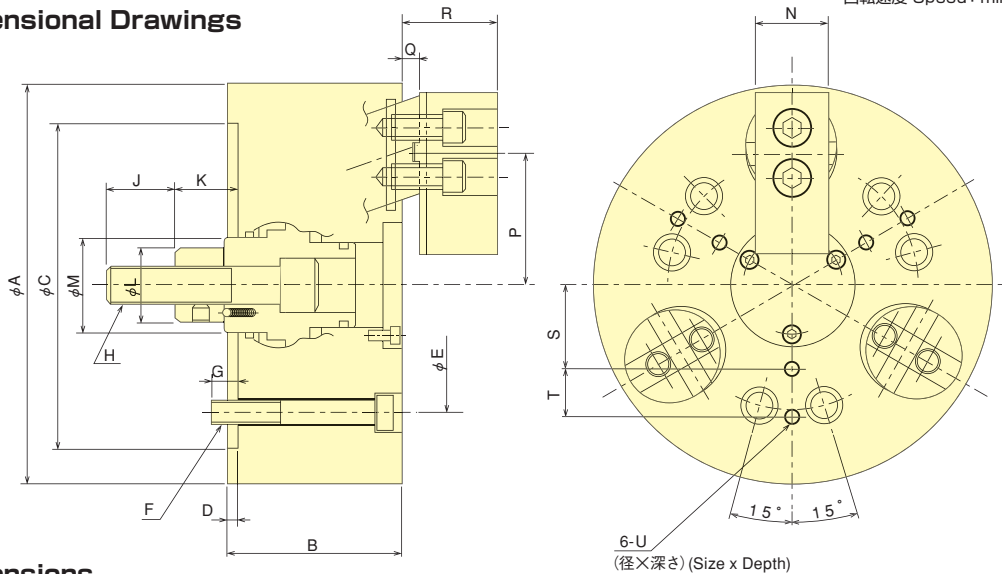

寸法表 Dimensions

型式 Model	A	B	C	D	E	F	G	H	J	K (max.)	K (min.)	L	M	N	P (max.)	P (min.)	Q (max.)	Q (min.)	R (max.)	R (min.)	S	T	U
LU-06	165	80	140	5	104.8	6-M10	16	M16x20	36	33	23	32	35	35	58.0	54.4	14	4	45	35	35	20	M6x12
LU-08	210	90	170	5	133.4	6-M12	15	M20x25	36	38	28	38	50	40	70.8	67.2	15	5	56	46	45	25	M8x15
LU-10	254	110	220	5	171.4	6-M16	24	M24x30	46	47	32	50	60	50	85.0	79.6	19	4	65	50	55	30	M8x15
LU-12	304	125	220	5	171.4	6-M16	24	M27x30	50	47	32	50	60	60	102.0	96.6	19	4	70	55	70	35	M10x17

仕様表 Specifications

※把握径/把握範囲は標準のソフトジョーを使用した場合。※Gripping dia./gripping range is with standard soft jaws.

仕様 Specs	ジョーストローク(直径) Jaw Stroke(diameter) mm	プランジャストローク Plunger Stroke mm	許容最大入力 Max. Draw Bar Pull Force kN	最大静的把握力 Max. Gripping Force kN	許容最高回転速度 Max. Speed min⁻¹	質量 Net Weight kg	慣性モーメント Moment of inertia kg·m²	適合シリンダ Matching Cylinder	許容最大油圧力 Max. pressure MPa	把握範囲 Gripping range mm
LU-06	7.2	10	15.0	25.2	3500	13.7	0.045	Y1020R/RE47	2.15	31~165
LU-08	7.2	10	25.0	45.0	3000	26.0	0.143	Y1225R/RE47	2.50	37~210
LU-10	10.8	15	35.0	60.0	2500	45.5	0.373	Y1225R/RE47	3.30	47~254
LU-12	10.8	15	45.0	75.0	2000	68.0	0.800	Y1530R/RE47	3.00	50~304

アドバンスチャック
Advanced Chuck



CHUCK

フィンガーチャック

FG(T) series

■ フェイスクランプ用 薄物ワークも安定把握

- ワーク表面を引込み把握するため、薄肉ワークを歪ませることなく安定した把握を可能としました
- リアボデーをアルミ製にして軽量化を図っているため高速回転で加工時間を短縮できます
- 球面プッシュの採用によりジョーがイコライズするため、ワークの偏肉も吸収し安定した把握が可能です(イコライズ量/最大2.5mm)
- チャック中心の貫通穴を設けていますので着座確認・エアブローの対応が可能です

*CE対応品



■ 寸法図

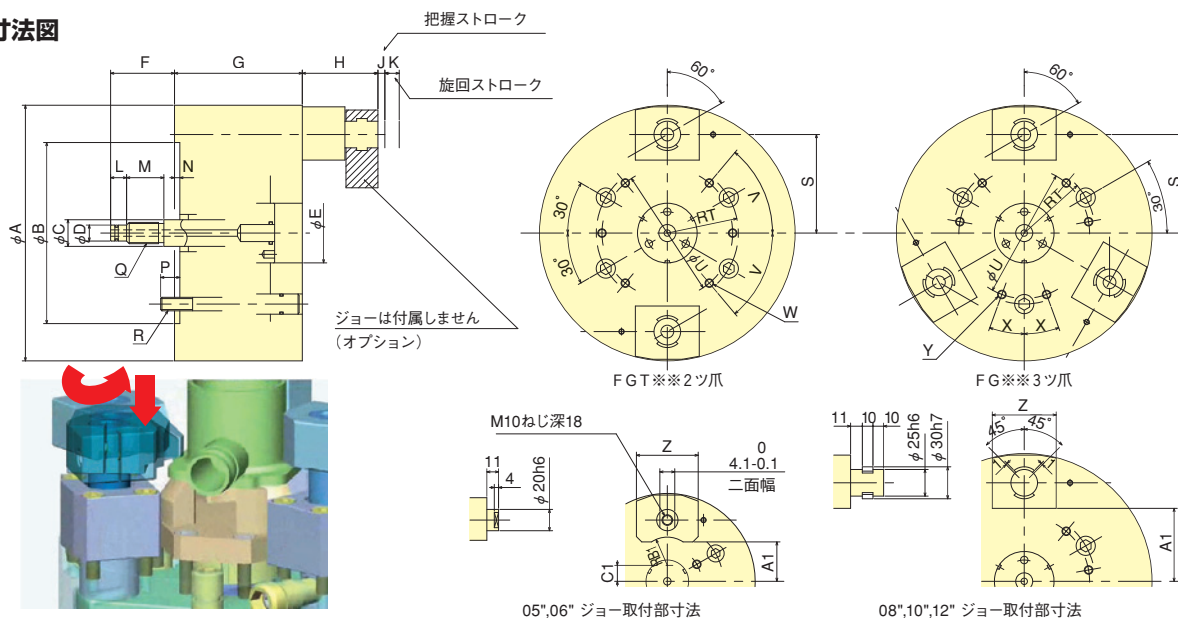

■ 寸法表 ※FGT: 2ツ爪, FG: 3ツ爪

寸法	A	B	C	D	E	F	G	H	J	K	L	M	N	P	Q	R	S	T	U	V	W	X	Y	Z	A1	B1	C1
FGT05/FG05	135	110	14	9	37	50-70	110	36-56	8	12	15	30	5	14	M12	M10	42.5	41.3	50	30°	4-M6 ねじ深 12	-	3-M6 ねじ深 12	58	22	26.5	-
FGT06/FG06	165	140	16	12	40	50-70	110	36-56	8	12	15	30	5	14	M16	M10	57.5	52.4	64	30°	4-M8 ねじ深 15	-	3-M8 ねじ深 15	58	37	26.5	15
FGT08/FG08	210	170	25	16	56	50-70	120	71-91	8	12	15	30	5	18	M20	M12	77.5	66.7	104	50°	6-M8 ねじ深 15	20°	6-M8 ねじ深 15	60	53.5	-	-
FGT10/FG10	254	220	25	16	56	50-70	120	71-91	8	12	15	30	5	24	M20	M16	99.5	85.7	140	50°	6-M8 ねじ深 15	20°	6-M8 ねじ深 15	60	75.5	-	-
FGT12/FG12	304	220	25	16	56	50-70	120	71-91	8	12	15	30	5	24	M20	M16	124.5	85.7	190	50°	6-M8 ねじ深 15	20°	6-M8 ねじ深 15	60	100.5	-	-

■ 仕様表 ※FGT: 2ツ爪, FG: 3ツ爪 ※1 ジョー長さ30mm時 ※2 ジョー長さ40mm

仕様	許容最大入力 kN	許容最高 回転速度 min ⁻¹	質量 kg	慣性モーメント kg·m ²	適合シリンダ	把握 ストローク mm	ジョー1ヶの 締付力 kN	最大把握径 dia. mm	オプションジョー での把握可能高さ	イコライズ量 mm	着座用シリンダ
FGT05/FG05	5.0 / 7.5	4000	10.0 / 12.0	0.025 / 0.030	Y1020R/RE	8	2.0 ※1	52	41	1	Y1020RE39
FGT06/FG06	6.0 / 9.0	4000	11.0 / 13.0	0.045 / 0.050	Y1020R/RE	8	2.5 ※1	78	41	1.5	Y1020RE39
FGT08/FG08	12.0 / 18.0	3500	22.0 / 24.0	0.130 / 0.140	Y1020R/RE	8	5.5 ※2	105	61	2	Y1020RE39
FGT10/FG10	12.0 / 18.0	3500	34.0 / 36.0	0.290 / 0.310	Y1020R/RE	8	5.5 ※2	150	61	2	Y1020RE39
FGT12/FG12	12.0 / 18.0	3000	46.0 / 48.0	0.570 / 0.590	Y1020R/RE	8	5.5 ※2	200	61	2.5	Y1020RE39

■ ブランクジョー(オプション)寸法図

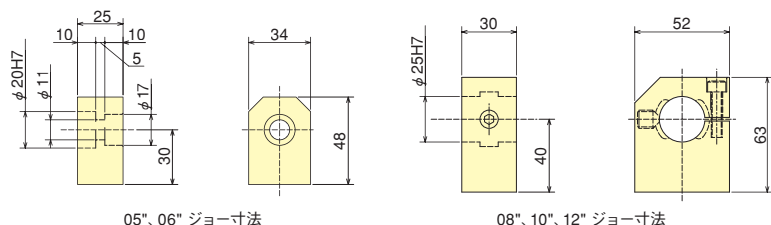

把握状態例

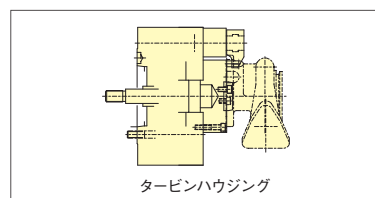



CHUCK

Finger Chuck FG(T) series

Face clamping chuck, ideal for thin walled work-pieces

- Distortion is reduced by using face clamping on thin section parts
- Using the aluminium rear body allows for high speed rotation, thus saving machining time
- Jaws include equalising mechanism to securely grip parts with variable thickness (Equalization amount/2.5 mm max)
- Through hole allows pneumatic accessories

*CE corresponding



アドバンスドチャック
Advanced Chuck

Dimensional Drawings

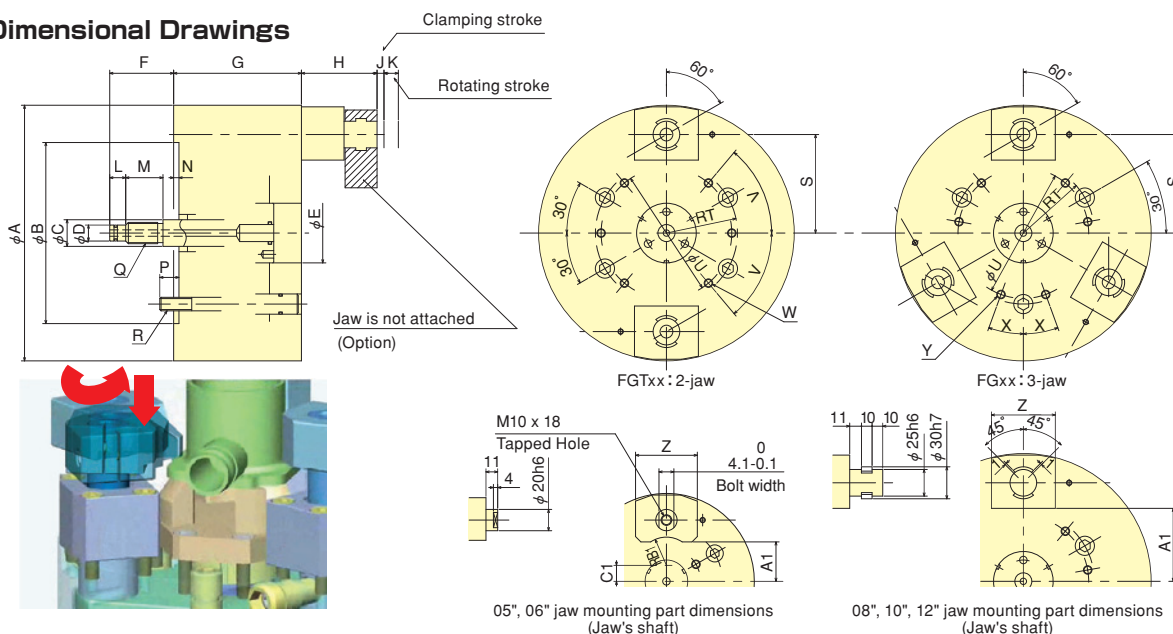

Dimensions *FGT : 2-jaw, FG : 3-jaw

Dimensions Model	A	B	C	D	E	F	G	H	J	K	L	M	N	P	Q	R	S	T	U	V	W	X	Y	Z	A1	B1	C1
FGT05/FG05	135	110	14	9	37	50-70	110	36-56	8	12	15	30	5	14	M12	M10	42.5	41.3	50	30°	4-M6 screw depth 12	-	3-M6 screw depth 12	58	22	26.5	-
FGT06/FG06	165	140	16	12	40	50-70	110	36-56	8	12	15	30	5	14	M16	M10	57.5	52.4	64	30°	4-M8 screw depth 15	-	3-M8 screw depth 15	58	37	26.5	15
FGT08/FG08	210	170	25	16	56	50-70	120	71-91	8	12	15	30	5	18	M20	M12	77.5	66.7	104	50°	6-M8 screw depth 15	20°	6-M8 screw depth 15	60	53.5	-	-
FGT10/FG10	254	220	25	16	56	50-70	120	71-91	8	12	15	30	5	24	M20	M16	99.5	85.7	140	50°	6-M8 screw depth 15	20°	6-M8 screw depth 15	60	75.5	-	-
FGT12/FG12	304	220	25	16	56	50-70	120	71-91	8	12	15	30	5	24	M20	M16	124.5	85.7	190	50°	6-M8 screw depth 15	20°	6-M8 screw depth 15	60	100.5	-	-

Specifications *FGT : 2-jaw, FG : 3-jaw *1-Jaw length : 30mm *2-Jaw length : 40mm

Specs Model	Max. Draw Bar Pull Force kN(kgf)	Max. Speed min ⁻¹	Net Weight kg	Moment of inertia kg·m ²	Matching Cylinder	Clamping stroke mm	Gripping force / jaw kN	Max. Gripping dia. mm	Limit height by optional jaw	Equalizing q'ty mm	Cylinder with seating
FGT05/FG05	5.0 / 7.5	4000	10.0 / 12.0	0.025 / 0.030	Y1020R/RE	8	2.0 *1	52	41	1	Y1020RE39
FGT06/FG06	6.0 / 9.0	4000	11.0 / 13.0	0.045 / 0.050	Y1020R/RE	8	2.5 *1	78	41	1.5	Y1020RE39
FGT08/FG08	12.0 / 18.0	3500	22.0 / 24.0	0.130 / 0.140	Y1020R/RE	8	5.5 *2	105	61	2	Y1020RE39
FGT10/FG10	12.0 / 18.0	3500	34.0 / 36.0	0.290 / 0.310	Y1020R/RE	8	5.5 *2	150	61	2	Y1020RE39
FGT12/FG12	12.0 / 18.0	3000	46.0 / 48.0	0.570 / 0.590	Y1020R/RE	8	5.5 *2	200	61	2.5	Y1020RE39

Dimensional Drawings for Blank Jaws (Option)

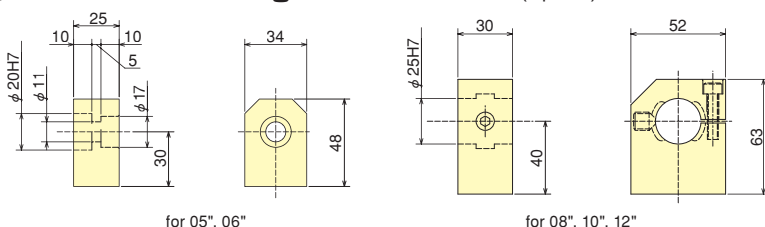

Gripping Examples

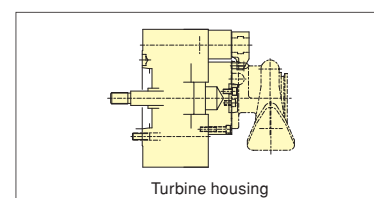



CHUCK

高剛性アルミホイール用フィンガーチャック Finger Chuck for Automotive Wheels FG-V series

**高剛性ボデー採用
Rigid body**

**4輪用アルミホイール加工に最適
Finger Chuck for aluminium wheel machining for automobiles**

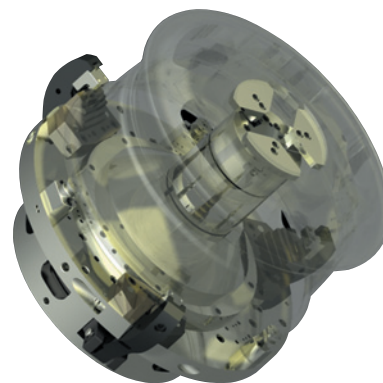

把握状態例 Gripping Examples

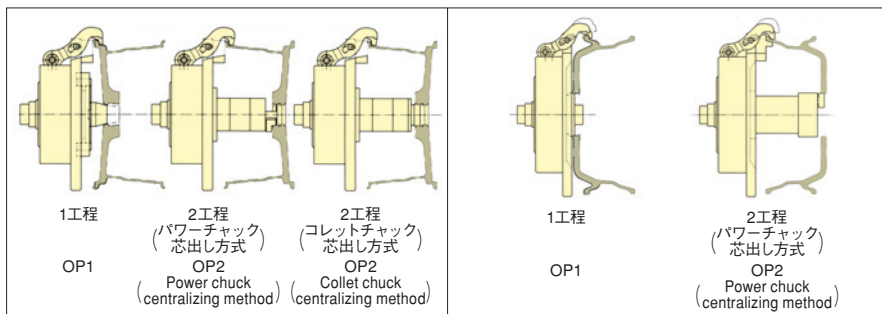

■ 寸法図 Dimensional Drawings

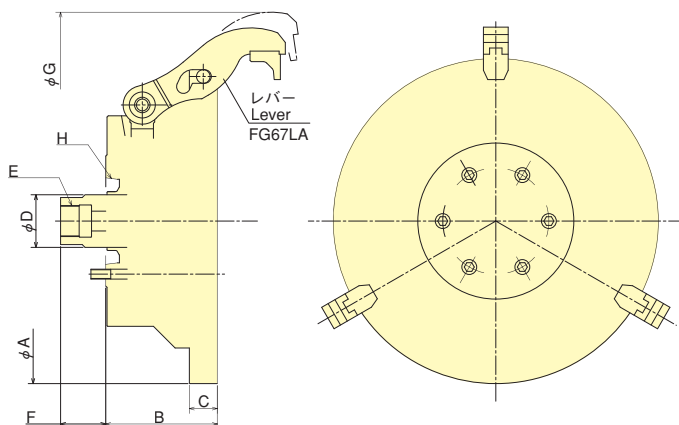

■ 寸法表 Dimensions

型式 Model	寸法 Dimensions	A	B	C	D	E	F max.	F min.	G	H
FG50V		525	180	45	85	M50×1.5	73	38	675	A2-8
FG56V		575	180	45	85	M50×1.5	73	38	725	A2-11
FG62V		625	180	45	85	M50×1.5	73	38	775	A2-11

■ 仕様表 Specifications

型式 Model	仕様 Specs	許容最大入力 Max. Draw Bar Pull Force kN	許容最高回転速度 Max. Speed min ⁻¹	質量 Net Weight kg	慣性モーメント Moment of inertia kg·m ²	開爪ストローク/直進ストローク Open jaw stroke/Clamping stroke mm	ジョー1個の締付力 Gripping force/jaw kN
FG50V		30.0	2500	135	3.75	18.5/16.5	9.5
FG56V		30.0	2500	190	5.8	18.5/16.5	9.5
FG62V		30.0	2200	220	8.8	18.5/16.5	9.5

■ ホイールサイズ対応表 Measurement table for Wheel

型式 Model	ホイールサイズ Wheel size	12"	13"	14"	15"	16"	17"	18"	19"	20"	21.5"	22.5"
FG50V			○	○	○	○	○	○				
FG56V			○	○	○	○	○	○	○	○		
FG62V						○	○	○	○	○	○	○



CHUCK

アルミホイール用フィンガーチャック Finger Chuck for Automotive Wheels FG-L series

軽量ボデーのKITAGAWAスタンダードタイプ Standard Finger Chuck with Light-Weight Body 4輪用アルミホイール加工に最適 Finger Chuck for aluminium wheel machining for automobiles

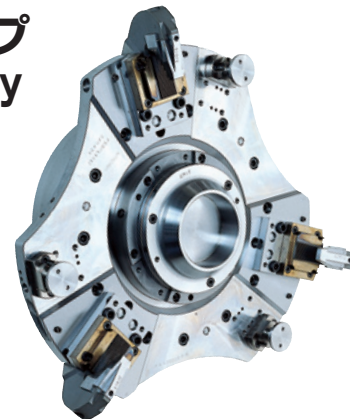

●高速回転にも対応できます High Speed

コンピューター解析を駆使した理想的な構造設計により最高回転数がフルサイズ(13~18)で3000min⁻¹まで可能となりました。

A technological breakthrough in the design has allowed a max speed of 3000 min⁻¹ for each wheel size (13"-18").

アドバンスチャック
Advanced Chuck

把握状態例 Gripping Examples

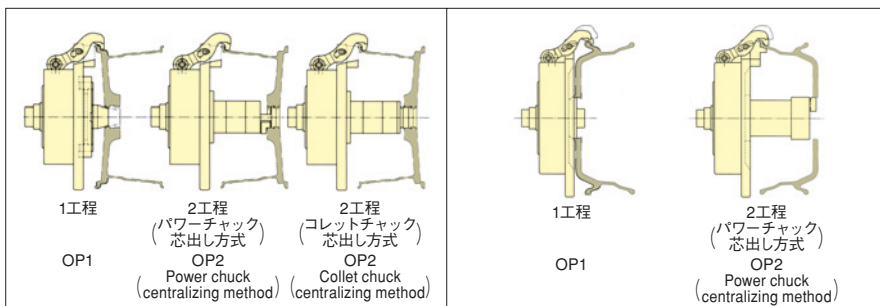

■寸法図 Dimensional Drawings

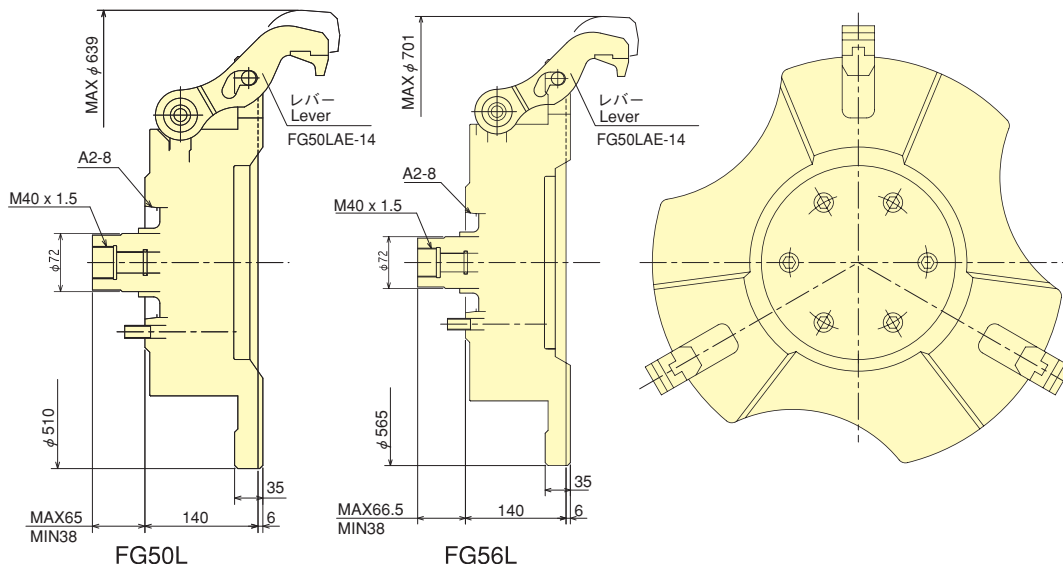

■仕様表 Specifications

型式 Model	仕様 Specs	許容最大入力 Max. Draw Bar Pull Force kN	許容最高回転速度 Max. Speed min ⁻¹	質量 Net Weight kg	慣性モーメント Moment of inertia kg·m ²	開爪ストローク/直進ストローク Open jaw stroke/Clamping stroke mm	ジョー1個の締付力 Gripping force/jaw kN
FG50L		30.0	3000	79	1.7	17/10	9.5
FG56L		30.0	2500	105	2.8	18.5/10	9.5

■ホイールサイズ対応表 Measurement table for Wheel

型式 Model	ホイールサイズ Wheel size	12"	13"	14"	15"	16"	17"	18"	19"	20"	21.5"	22.5"
FG50L			○	○	○	○	○	○				
FG56L			○	○	○	○	○	○	○	○		



CHUCK

2輪アルミホイール用フィンガーチャック Finger Chuck for motor cycle wheels FG-M series

2輪用アルミホイール加工に最適 Finger Chuck for aluminium wheel machining for motorcycles

●安定性も抜群です High Stability

フローティング機構の採用によりぶれのない安定したチャッキングが行えます。
The floating mechanism ensures firm chucking.

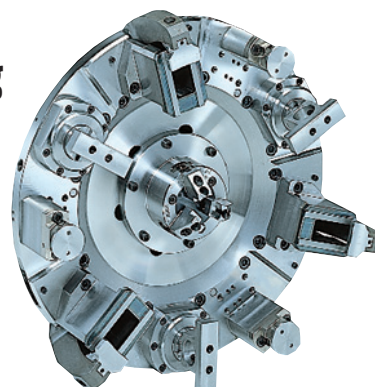

把握状態例 Gripping Examples

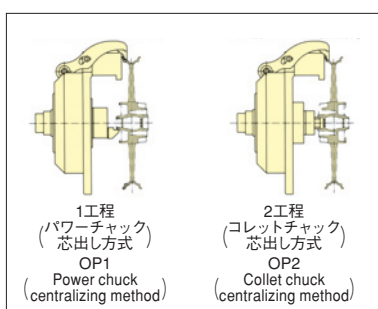

■ 寸法図 Dimensional Drawings

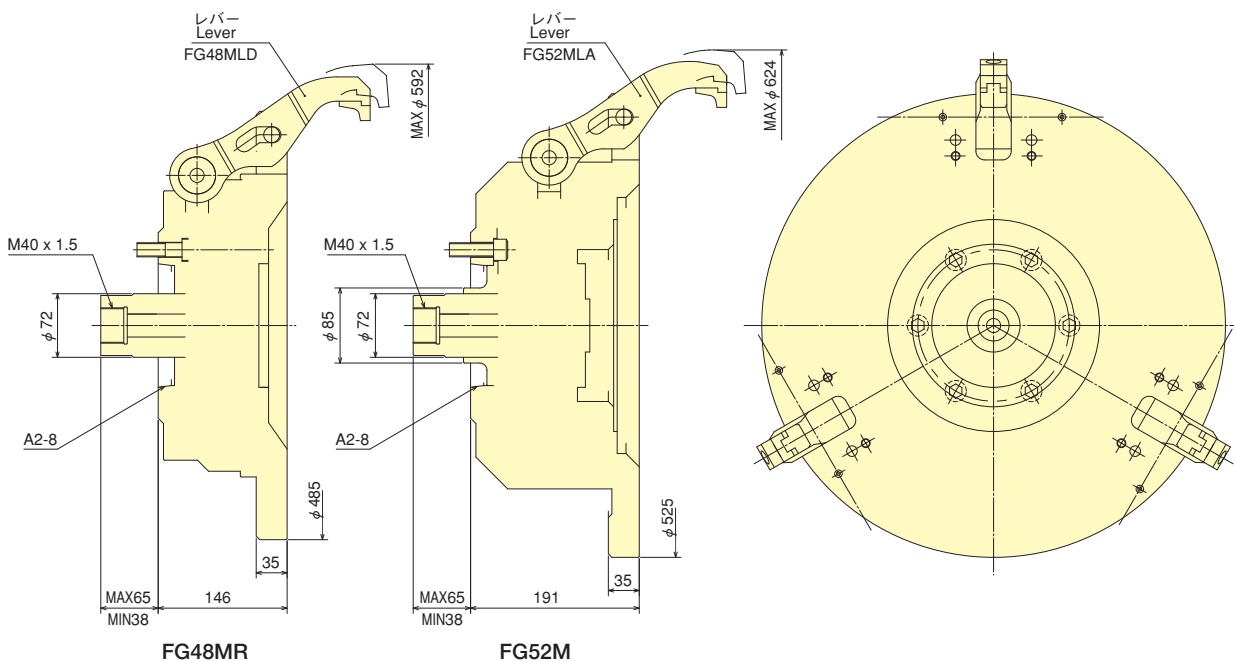

■ 仕様表 Specifications

仕様 Model	仕様 Specs	許容最大入力 Max. Draw Bar Pull Force kN	許容最高回転速度 Max. Speed min ⁻¹	質量 Net Weight kg	慣性モーメント Moment of inertia kg·m ²	開爪ストローク/直進ストローク Open jaw stroke/Clamping stroke mm	ジョー1個の締付力 Gripping force/jaw kN
FG48MR		12.0	2500	84	1.9	14/13	3.5
FG52M		21.0	2500	130.0	3.650	14/13	6.5

■ ホイールサイズ対応表 Measurement table for Wheel

ホイールサイズ Wheel size Model	12"	13"	14"	15"	16"	17"	18"	19"	20"	21.5"	22.5"
FG48MR	○	○	○	○	○	○	○	○			
FG52M	○	○	○	○	○	○	○	○			



CHUCK

省段取りアルミホイール用フィンガーチャック Easy Preparation Finger Chuck for Automotive Wheels

FG-Q series

インチ変更の段取りが短時間で
Quick set-up for size changes

4輪用アルミホイール加工に最適
Finger Chuck for aluminium wheel machining for automobiles



アドバンスドチャック
Advanced Chuck

- ホイールサイズ変更の段取りが容易です
Easy preparation for each size of Wheel

- 段取り時間が約30秒です
The setup time is approximately 30 seconds

インチ変更の段取り時、ハンドルを回すだけで3箇所のレバーと固定ジグが同時にストロークするので短時間でセットアップができます。

Due to the preparation for each size, three levers and fixed jigs are moved simultaneously simply by rotating the handle, thus saving the setup time.

■ 寸法図 Dimensional Drawings

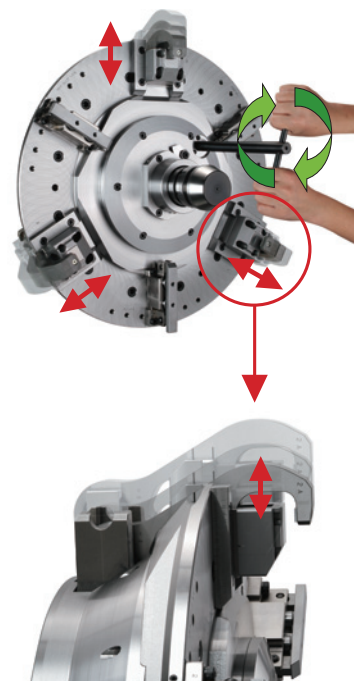
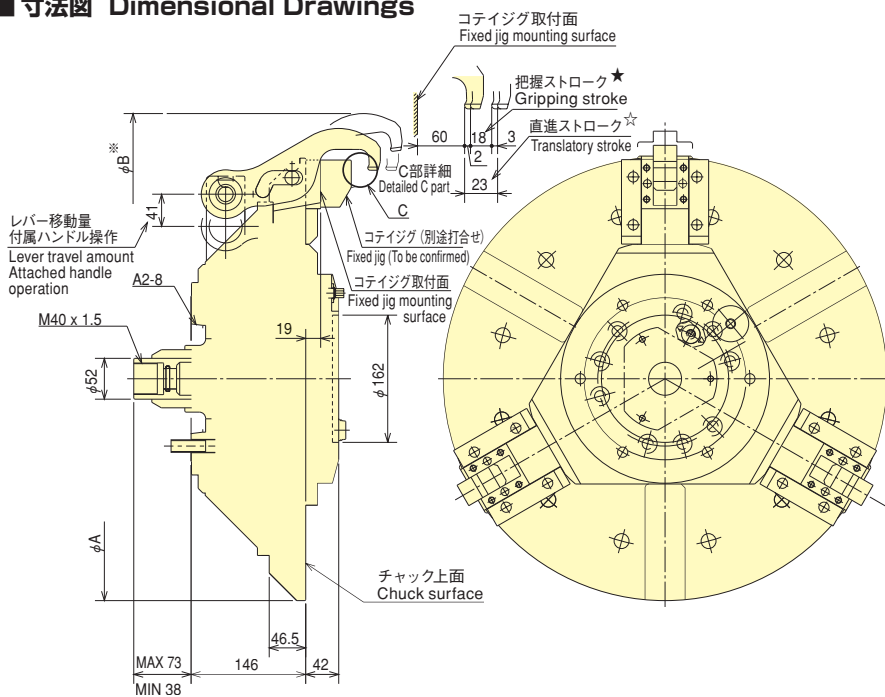

■ 寸法表 Dimensions

※Bはレバー A使用時
※B shows the state in use of the lever A.

型式 Model	寸法 Dimensions	
	A	B※
FG56Q	565	672
FG62Q	620	727

■ 仕様表 Specifications

仕様 Specs	ジョーストローク Jaw Stroke			許容最大入力 Max. Draw Bar Pull Force kN	許容最高 回転速度 Max. Speed min ⁻¹	質量 Net Weight kg	慣性モーメント Moment of inertia kg·m ²	ジョー1個 の締付力 Gripping force /jaw kN
	全ストローク Full Stroke mm	直進/把握*ストローク Translatory*/ Gripping* Stroke mm	開爪ストローク Open jaw Stroke mm					
型式 Model								
FG56Q	35	23/18	12	30.0	2500	117.5	4.130	9.5
FG62Q					2200	195.0	7.500	

■ ホイールサイズ対応表 Measurement table for Wheel

型式 Model	ホイールサイズ Wheel size レバー Lever	13	14	15	16	17	18	19	20	21	22
		FG56Q	A					○	○	○	○
	C	○	○	○	○	○	○	○	○		
	B (オプション)			○	○	○	○	○	○		
FG62Q	A			○	○	○	○	○	○		
	C			○	○	○	○	○	○		
	B (オプション)				○	○	○	○	○		



**ROTARY
CYLINDER**

▶ **P.67~P.83**

シリンダ Cylinder

KITAGAWAチャック専用 シリンダシリーズ Cylinder Series exclusive for KITAGAWA Chucks

スタンダードチャックからアドバンスチャックまで
KITAGAWAのすべてのチャックに対応出来る高性能
で機能が充実したラインナップです。
組み合わせの選定は、ご相談ください。

From standard to advanced type, a recognised
line-up of high performance cylinders
accommodates every KITAGAWA chuck.
When selecting the combination of chuck
cylinders, contact us.



ROTARY
CYLINDER

中空回転油圧シリンダ

SR series

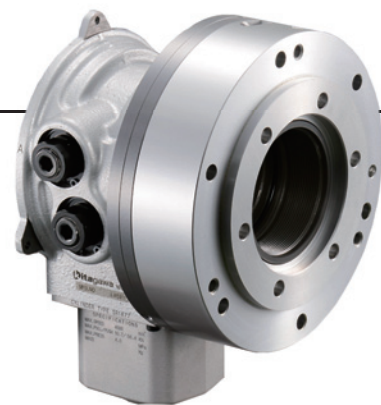

KITAGAWAチャックの仕様に合わせた最適設計

- 大きな貫通穴を実現
- クーラントコレクタ無しの仕様です。
クーラントコレクタ付はSR_Cシリーズをご覧ください。

■ 寸法図

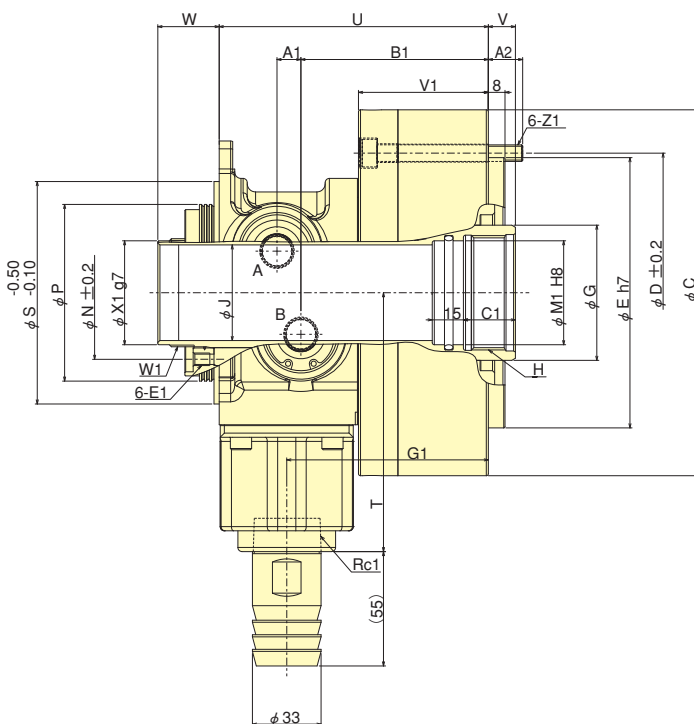
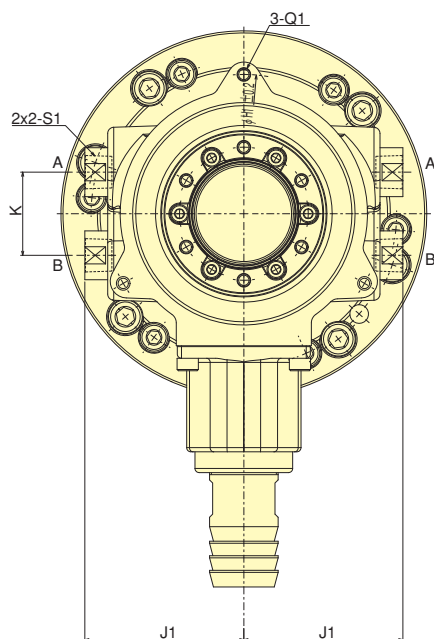

■ 寸法表

寸法	C	D	E	G	H	J	K	N	P	S	T	U	V	V	W	W	A1	B1	C1	E1	G1	H1	J1	M1	Q1	S1	V1	W1	X1	Z1	A2
型式													max.	min.	max.	min.															
SR1146	176	147	130	65	M55x2	46	40	64	85	107	124.5	129.5	13	-3	45.5	29.5	11.5	90.2	25	M6x8	97	134	76.5	50	M6	Rc3/8	62.5	M52x1.5	50	M8	16.5
SR1453	200	165	140	70	M60x2	53	40	73	96	117	130	133.5	19	0	53	34	11.5	94.2	30	M6x12	101	144	82.5	55	M6	Rc3/8	66.5	M68x1.5	56	M8	13
SR1566	210	190	168	85	M75x2	66	48	88	111	137	150	154.5	22	0	52	30	12.7	107.9	35	M6x12	108	169	98	70	M6	Rc1/2	73	M74x1.5	71.5	M10	18
SR1670	222	195	160	95	M78x2	70	46	103	126	157	175	171	22	-1	53	30	15.5	115.5	35	M6x12	122.5	189	98.5	75	M6	Rc1/2	72	M89x2	86	M10	19
SR1675	222	195	160	95	M85x2	75	46	103	126	157	175	171	22	-1	53	30	15.5	115.5	35	M6x12	122.5	189	98.5	80	M6	Rc1/2	72	M89x2	86	M10	19
SR1677	222	195	160	100	M88x2	77	46	103	126	157	175	171	22	-1	53	30	15.5	115.5	35	M6x12	122.5	189	98.5	80	M6	Rc1/2	72	M89x2	86	M10	19
SR1781	230	205	168	100	M90x2	81	46	103	126	157	175	176	23	-2	55	30	15.5	120.5	35	M6x12	127.5	189	98.5	85	M6	Rc1/2	77	M89x2	86	M10	19

■ 仕様表

型式	仕様		ピストン表面積		ピストン推力		最高使用油圧力 MPa	許容最高回転速度 min ⁻¹	慣性モーメント kg·m ²	質量 kg	総リーク量 ℓ/min
	貫通穴径 mm	ピストンストローク mm	押側 cm ²	引側 cm ²	押側 kN	引側 kN					
SR1146	46	16	87	76	32.8	28.6	4.0	6000	0.026	11	3.0
SR1453	53	19	121	111	47.9	43.9	4.2	6000	0.045	14	3.9
SR1566	66	22	132	120	49.7	45.0	4.0	5000	0.064	19	4.0
SR1670	70	23	150	143	56.4	53.6	4.0	4500	0.086	24.5	4.3
SR1675	75	23	150	143	56.4	53.6	4.0	4500	0.084	23.5	4.3
SR1677	77	23	150	135	56.4	50.7	4.0	4500	0.084	23.5	4.3
SR1781	81	25	171	156	64.3	58.7	4.0	4500	0.095	23.5	4.3

※総リーク量：油圧力3.0MPa、油温50℃の時 ※ピストン推力：最高使用油圧力時



ROTARY CYLINDER

Next-Generation Hydraulic Cylinder with Large Through-Hole

SR series

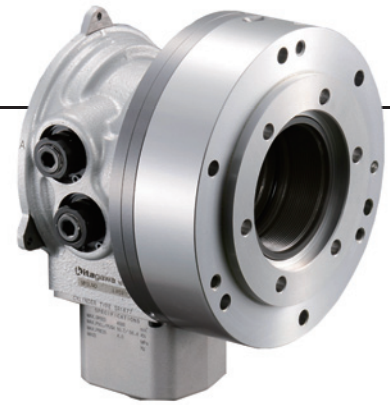

Suitable design for KITAGAWA chuck

- Large through-hole
- This model is not equipped with a coolant collector. For models equipped with a coolant collector, please see the SR_C series.

Dimensional Drawings

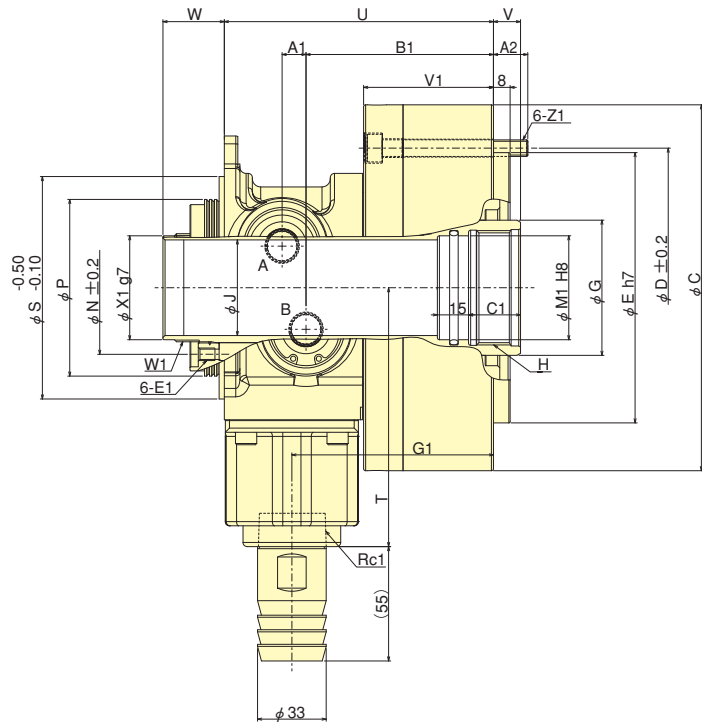
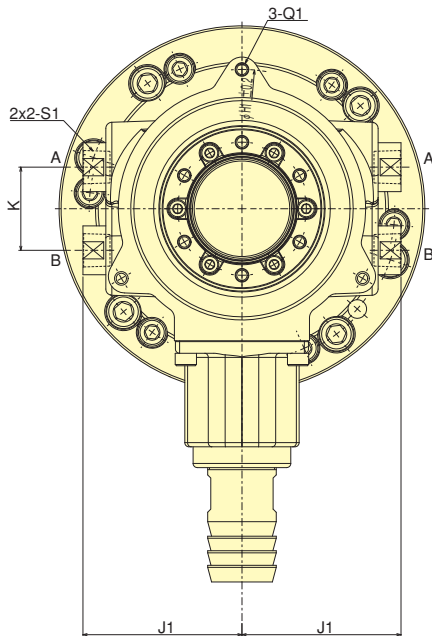

Dimensions

Dimensions	C	D	E	G	H	J	K	N	P	S	T	U	V max.	V min.	W max.	W min.	A1	B1	C1	E1	G1	H1	J1	M1	Q1	S1	V1	W1	X1	Z1	A2
SR1146	176	147	130	65	M55x2	46	40	64	85	107	124.5	129.5	13	-3	45.5	29.5	11.5	90.2	25	M6x8	97	134	76.5	50	M6	Rc3/8	62.5	M52x1.5	50	M8	16.5
SR1453	200	165	140	70	M60x2	53	40	73	96	117	130	133.5	19	0	53	34	11.5	94.2	30	M6x12	101	144	82.5	55	M6	Rc3/8	66.5	M68x1.5	56	M8	13
SR1566	210	190	168	85	M75x2	66	48	88	111	137	150	154.5	22	0	52	30	12.7	107.9	35	M6x12	108	169	98	70	M6	Rc1/2	73	M74x1.5	71.5	M10	18
SR1670	222	195	160	95	M78x2	70	46	103	126	157	175	171	22	-1	53	30	15.5	115.5	35	M6x12	122.5	189	98.5	75	M6	Rc1/2	72	M89x2	86	M10	19
SR1675	222	195	160	95	M85x2	75	46	103	126	157	175	171	22	-1	53	30	15.5	115.5	35	M6x12	122.5	189	98.5	80	M6	Rc1/2	72	M89x2	86	M10	19
SR1677	222	195	160	100	M88x2	77	46	103	126	157	175	171	22	-1	53	30	15.5	115.5	35	M6x12	122.5	189	98.5	80	M6	Rc1/2	72	M89x2	86	M10	19
SR1781	230	205	168	100	M90x2	81	46	103	126	157	175	176	23	-2	55	30	15.5	120.5	35	M6x12	127.5	189	98.5	85	M6	Rc1/2	77	M89x2	86	M10	19

Specifications

Specifications	Thru-Hole mm	Piston stroke mm	Piston Area		Piston thrust		Max. Operation Pressure MPa	Max. Speed min ⁻¹	Moment of Inertia kg·m ²	Net Weight kg	Leakage ℓ /min
			Push Side cm ²	Pull Side cm ²	Push Side kN	Pull Side kN					
SR1146	46	16	87	76	32.8	28.6	4.0	6000	0.026	11	3.0
SR1453	53	19	121	111	47.9	43.9	4.2	6000	0.045	14	3.9
SR1566	66	22	132	120	49.7	45.0	4.0	5000	0.064	19	4.0
SR1670	70	23	150	143	56.4	53.6	4.0	4500	0.086	24.5	4.3
SR1675	75	23	150	143	56.4	53.6	4.0	4500	0.084	23.5	4.3
SR1677	77	23	150	135	56.4	50.7	4.0	4500	0.084	23.5	4.3
SR1781	81	25	171	156	64.3	58.7	4.0	4500	0.095	23.5	4.3

※Leakage:Pressure 3.0MPa and oil temperature 50℃ ※Piston thrust:at Max.Operation Pressure

回転
シリンダー
Cylinder



ROTARY CYLINDER

中空回転油圧シリンダ

SR_C series

KITAGAWAチャックの仕様に合わせた最適設計

- 大きな貫通穴を実現
- クーラントコレクタと確認装置が標準装備
- リニアセンサ仕様を選択可能
 - ※機械メーカーによってはリニアセンサ仕様が使用できない場合があります。機械メーカーへご確認ください。
 - ※オプションについてはP76を参照してください。
- ※CE対応品（確認装置付のみ）

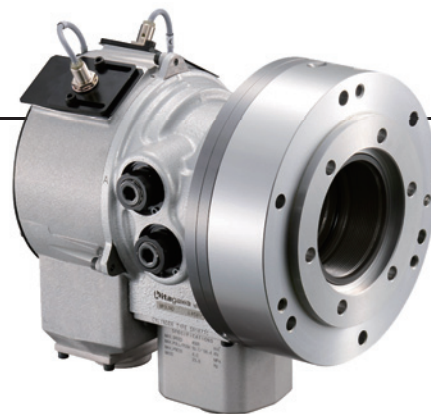

近接スイッチは付属していません。お客様の制御装置に合わせて、寸法図を参考に ご用意願います。

■ 寸法図

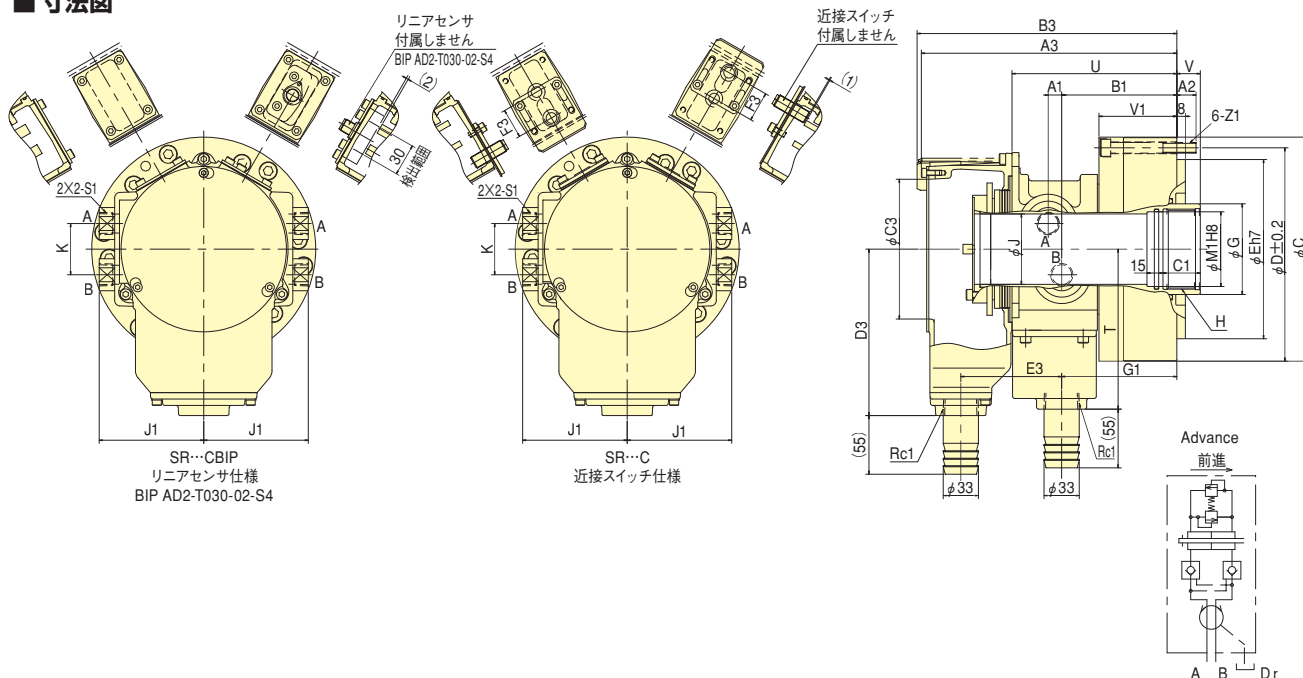

■ 寸法表

型式	C	D	E	G	H	J	K	N	P	S	T	U	V max.	V min.	W max.	W min.	A1	B1	C1	E1	G1	H1	J1	M1	Q1	S1	V1	W1	X1	Z1	A2
SR1146C	176	147	130	65	M55x2	46	40	64	85	107	124.5	129.5	13	-3	45.5	29.5	11.5	90.2	25	M6x8	97	134	76.5	50	M6	Rc3/8	62.5	M62x1.5	50	M8	16.5
SR1453C	200	165	140	70	M60x2	53	40	73	96	117	130	133.5	19	0	53	34	11.5	94.2	30	M6x12	101	144	82.5	55	M6	Rc3/8	66.5	M68x1.5	56	M8	13
SR1566C	210	190	168	85	M75x2	66	48	88	111	137	150	154.5	22	0	52	30	12.7	107.9	35	M6x12	108	169	98	70	M6	Rc1/2	73	M74x1.5	71.5	M10	18
SR1670C	222	195	160	95	M78x2	70	46	103	126	157	175	171	22	-1	53	30	15.5	115.5	35	M6x12	122.5	189	98.5	75	M6	Rc1/2	72	M89x2	86	M10	19
SR1675C	222	195	160	95	M85x2	75	46	103	126	157	175	171	22	-1	53	30	15.5	115.5	35	M6x12	122.5	189	98.5	80	M6	Rc1/2	72	M89x2	86	M10	19
SR1677C	222	195	160	100	M88x2	77	46	103	126	157	175	171	22	-1	53	30	15.5	115.5	35	M6x12	122.5	189	98.5	80	M6	Rc1/2	72	M89x2	86	M10	19
SR1781C	230	205	168	100	M90x2	81	46	103	126	157	175	176	23	-2	55	30	15.5	120.5	35	M6x12	127.5	189	98.5	85	M6	Rc1/2	77	M89x2	86	M10	19

※SR...CとSR...CBIPは同じ寸法

■ クーラントコレクタ 近接スイッチタイプ

型式	A3 全長	B3 全長 MAX	C3	D3	E3	F3
SR1146C	202.5	204.5	98	109.5	68.5	24
SR1453C	212.5	216.5	110	117.5	74.5	25
SR1566C	239.5	243.5	131	156	94.5	28
SR1670C	262	266	151	159.5	102.5	28
SR1675C	262	266	151	159.5	102.5	28
SR1677C	262	266	151	159.5	102.5	28
SR1781C	267	271	151	159.5	102.5	28

■ クーラントコレクタ リニアセンサタイプ

型式	A3 全長	B3 全長 MAX	C3	D3	E3
SR1146CBIP	202.5	-	98	109.5	68.5
SR1453CBIP	212.5	-	110	117.5	74.5
SR1566CBIP	239.5	-	131	156	94.5
SR1670CBIP	262	-	151	159.5	102.5
SR1675CBIP	262	-	151	159.5	102.5
SR1677CBIP	262	-	151	159.5	102.5
SR1781CBIP	267	-	151	159.5	102.5

■ 仕様表

型式	貫通穴径 mm	ピストンストローク mm	ピストン表面積		ピストン推力		最高使用油圧力 MPa	許容最高回転速度 min ⁻¹	慣性モーメント kg·m ²	質量 kg	総リーク量 ℓ/min
			押側 cm ²	引側 cm ²	押側 kN	引側 kN					
SR1146C	46	16	87	76	32.8	28.6	4.0	6000	0.026	13	3.0
SR1453C	53	19	121	111	47.9	43.9	4.2	6000	0.045	16	3.9
SR1566C	66	22	132	120	49.7	45.0	4.0	5000	0.064	21.5	4.0
SR1670C	70	23	150	143	56.4	53.6	4.0	4500	0.086	27.5	4.3
SR1675C	75	23	150	143	56.4	53.6	4.0	4500	0.084	26.5	4.3
SR1677C	77	23	150	135	56.4	50.7	4.0	4500	0.084	26	4.3
SR1781C	81	25	171	156	64.3	58.7	4.0	4500	0.095	26.5	4.3

※SR...C、SR...CBIPは同じ

※総リーク量：油圧力3.0MPa、油温50℃の時

※ピストン推力：最高使用油圧力時



ROTARY CYLINDER

Next-Generation Hydraulic Cylinder with Large Through-Hole

SR_C series

Suitable design for KITAGAWA chuck

- Large through-hole
- Coolant collector and confirmation devices are equipped as a standard
- Linear sensor can be available
 - ※Linear sensor specifications may not be available depending on the machine manufacturer. Please confirm with the manufacturer.
 - ※Please refer to P76 about options.
 - *CE corresponding (Only series with confirmation device)



The proximity switch is optional.
Determine the appropriate type according to the controller type and dimension drawing.

Dimensional Drawings

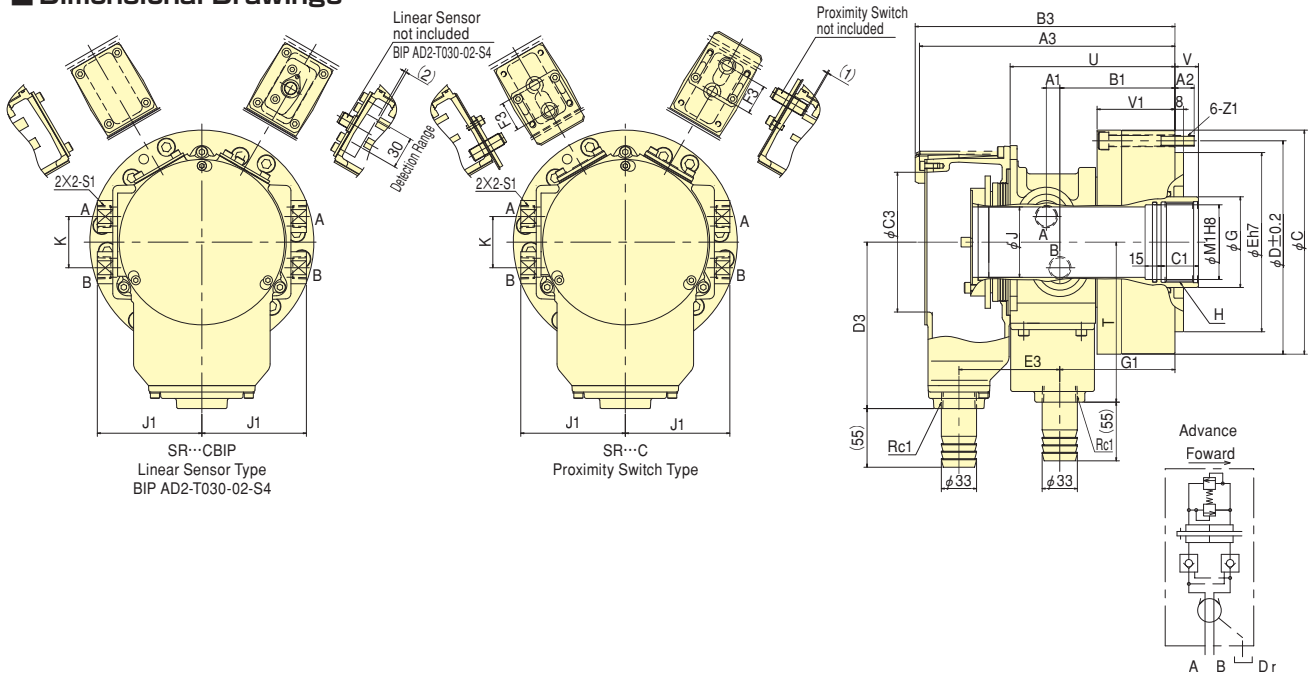

Dimensions

Dimensions	C	D	E	G	H	J	K	N	P	S	T	U	V max.	V min.	W max.	W min.	A1	B1	C1	E1	G1	H1	J1	M1	Q1	S1	V1	W1	X1	Z1	A2
SR1146C	176	147	130	65	M55x2	46	40	64	85	107	124.5	129.5	13	-3	45.5	29.5	11.5	90.2	25	M6x8	97	134	76.5	50	M6	Rc3/8	62.5	M62x1.5	50	M8	16.5
SR1453C	200	165	140	70	M60x2	53	40	73	96	117	130	133.5	19	0	53	34	11.5	94.2	30	M6x12	101	144	82.5	55	M6	Rc3/8	66.5	M68x1.5	56	M8	13
SR1566C	210	190	168	85	M75x2	66	48	88	111	137	150	154.5	22	0	52	30	12.7	107.9	35	M6x12	108	169	98	70	M6	Rc1/2	73	M74x1.5	71.5	M10	18
SR1670C	222	195	160	95	M78x2	70	46	103	126	157	175	171	22	-1	53	30	15.5	115.5	35	M6x12	122.5	189	98.5	75	M6	Rc1/2	72	M89x2	86	M10	19
SR1675C	222	195	160	95	M85x2	75	46	103	126	157	175	171	22	-1	53	30	15.5	115.5	35	M6x12	122.5	189	98.5	80	M6	Rc1/2	72	M89x2	86	M10	19
SR1677C	222	195	160	100	M88x2	77	46	103	126	157	175	171	22	-1	53	30	15.5	115.5	35	M6x12	122.5	189	98.5	80	M6	Rc1/2	72	M89x2	86	M10	19
SR1781C	230	205	168	100	M90x2	81	46	103	126	157	175	176	23	-2	55	30	15.5	120.5	35	M6x12	127.5	189	98.5	85	M6	Rc1/2	77	M89x2	86	M10	19

※SR-C, has the same dimension as SR-CBIP

Coolant Collector Proximity Switch Type

Dimensions	A3 length	B3 length MAX	C3	D3	E3	F3
SR1146C	202.5	204.5	98	109.5	68.5	24
SR1453C	212.5	216.5	110	117.5	74.5	25
SR1566C	239.5	243.5	131	156	94.5	28
SR1670C	262	266	151	159.5	102.5	28
SR1675C	262	266	151	159.5	102.5	28
SR1677C	262	266	151	159.5	102.5	28
SR1781C	267	271	151	159.5	102.5	28

Coolant Collector Linear Sensor Type

Dimensions	A3 length	B3 length MAX	C3	D3	E3
SR1146CBIP	202.5	-	98	109.5	68.5
SR1453CBIP	212.5	-	110	117.5	74.5
SR1566CBIP	239.5	-	131	156	94.5
SR1670CBIP	262	-	151	159.5	102.5
SR1675CBIP	262	-	151	159.5	102.5
SR1677CBIP	262	-	151	159.5	102.5
SR1781CBIP	267	-	151	159.5	102.5

Specifications

Specifications	Thru-Hole mm	Piston stroke mm	Piston Area		Piston thrust		Max. Operation Pressure MPa	Max. Speed min ⁻¹	Moment of Inertia kg·m ²	Net Weight kg	Leakage l/min
			Push Side cm ²	Pull Side cm ²	Push Side kN	Pull Side kN					
SR1146C	46	16	87	76	32.8	28.6	4.0	6000	0.026	13	3.0
SR1453C	53	19	121	111	47.9	43.9	4.2	6000	0.045	16	3.9
SR1566C	66	22	132	120	49.7	45.0	4.0	5000	0.064	21.5	4.0
SR1670C	70	23	150	143	56.4	53.6	4.0	4500	0.086	27.5	4.3
SR1675C	75	23	150	143	56.4	53.6	4.0	4500	0.084	26.5	4.3
SR1677C	77	23	150	135	56.4	50.7	4.0	4500	0.084	26	4.3
SR1781C	81	25	171	156	64.3	58.7	4.0	4500	0.095	26.5	4.3

※SR-C, has the same specifications as SR-CBIP ※Leakage: Pressure 3.0MPa and oil temperature 50°C ※Piston thrust: at Max. Operation Pressure



ROTARY CYLINDER

短寸中空回転油圧シリンダ

SS series

BB200,B-200シリーズに対応 旋盤の機能を十分に発揮させるコンパクト設計

- 全長が従来型の2/3のコンパクトサイズに
 - 回転速度がさらにUP
 - 最高油圧力もさらにUP (1サイズ上のチャックにも対応可能)
 - クーラントコレクタや確認装置がオプションで選択可能
- ※オプションについてはP76を参照してください。
*CE対応品 (確認装置付のみ)



■ 寸法図

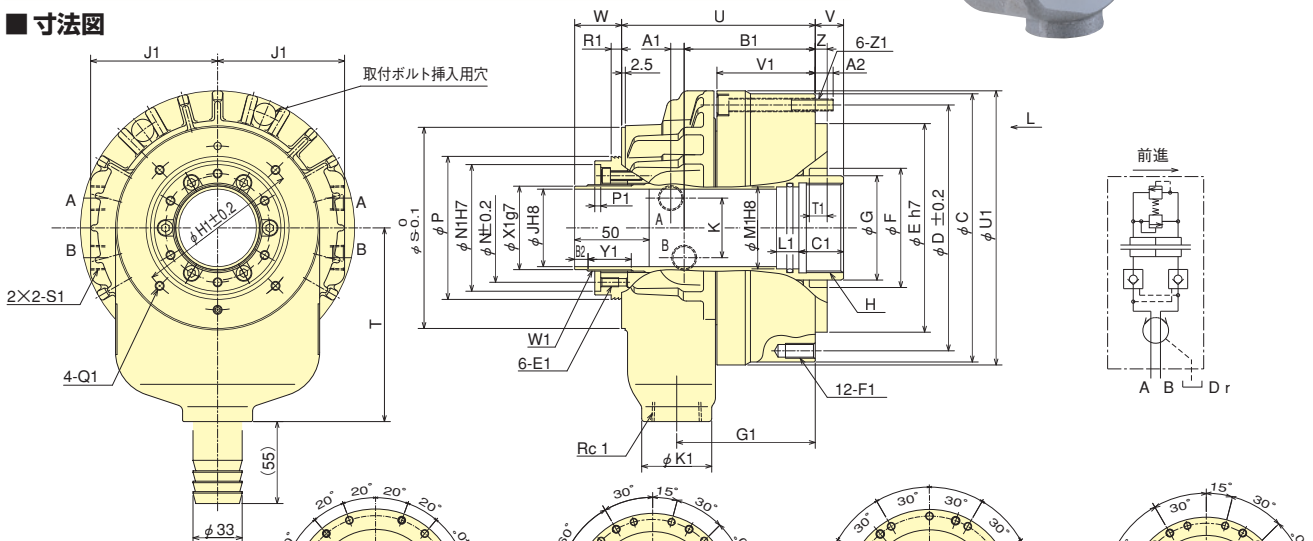

■ L矢視図

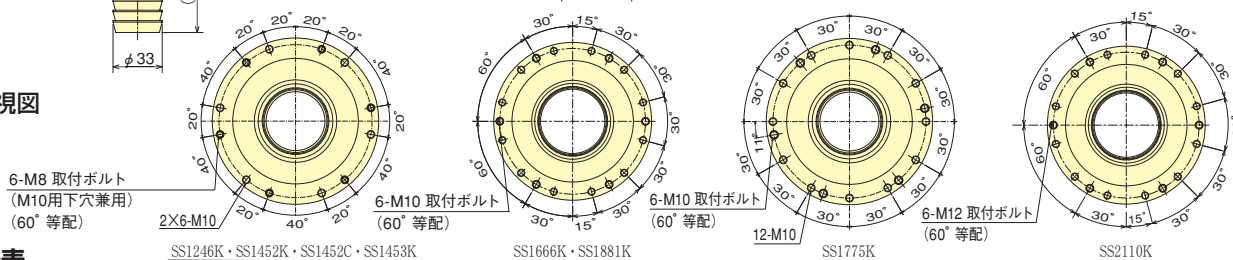

■ 寸法表

型式	寸法																				
	C	D	E	F	G	H	J	K	N	P	S	T	U	V	V	W	W	Z	A1	B1	C1
SS1246K	162	147	130	75	65	M55×2	46	40	64	85	116	120	120	13	-3	45.0	29.0	8	8.5	79.5	25
SS1452K	180	165	140	80	70	M60×2	52	40	73	96	135	130	130	19	-3	53.5	31.5	8	9.0	88.0	30
SS1452C	180	165	140	80	70	M60×2	52	40	73	96	135	130	130	19	-3	47.0	25.0	8	9.0	88.0	30
SS1453K	180	165	140	80	70	M60×2	53	40	73	96	135	130	130	19	-3	53.5	31.5	8	9.0	88.0	30
SS1666K	207	190	168	95	85	M75×2	66	48	88	111	154	150	150	22	-3	58.0	33.0	8	13.0	99.5	35
SS1775K	212	195	160	105	95	M85×2	75	46	98	121	164	160	157	22	-3	57.0	32.0	8	17.5	99.0	35
SS1881K	222	205	168	110	100	M90×2	81	46	103	126	175	175	167	23	-2	58.0	33.0	8	17.0	106.0	35
SS2110K	260	240	200	135	125	M115×2	106	46	133	160	210	200	192	27	-3	64.0	34.0	8	20.0	120.5	35

型式	寸法																					
	E1 深さ	F1 深さ	G1	H1	J1	K1	L1	M1	N1	P1	Q1 深さ	R1	S1	T1	U1	V1	W1	X1	Y1	Z1	A2	B2
SS1246K	M6×10	M10×20	84	98	76	47	15	50	76	4	M5×6	6.5	Rc3/8	12	165	57.5	M52×1.5	50.0	29	M8	15	9
SS1452K	M6×12	M10×20	93	110	86	47	15	55	85	4	M6×6	7.0	Rc3/8	12	184	66.0	M58×1.5	56.0	30	M8	12	8
SS1452C	M6×9.5	M10×20	93	110	86	47	15	55	85	4	M6×6	9.5	Rc3/8	12	184	66.0	M58×1.5	56.0	29	M8	12	9
SS1453K	M6×12	M10×20	93	110	86	47	15	55	85	4	M6×6	7.0	Rc3/8	12	184	66.0	M58×1.5	56.0	30	M8	12	8
SS1666K	M6×12	M12×24	108	145	97	47	15	70	100	4	M6×10	16.5	Rc1/2	12	211	71.0	M74×1.5	71.5	36	M10	19	9
SS1775K	M6×12	M10×20	110	155	100	47	15	80	108	4	M6×10	14.0	Rc1/2	12	216	71.0	M84×2.0	81.0	33	M10	18	9
SS1881K	M6×12	M12×24	115	166	105	47	15	85	113	4	M6×10	16.5	Rc1/2	12	226	71.0	M89×2.0	86.0	38	M10	19	9
SS2110K	M6×12	M12×24	130	201	124	47	15	110	145	4	M6×10	16.0	Rc1/2	12	263	79.5	M118×2.0	115.0	45	M12	18	9

■ 仕様表

※ピストン推力：最高使用油圧力時
※ドレン量：油圧力3.0MPa、油温50℃の時

型式	仕様	ピストンストローク		ピストン表面積		ピストン推力		最高使用油圧力 MPa	許容最高回転速度 min ⁻¹	慣性モーメント kg·m ²	質量 kg	ドレン量 ℓ/min
		mm	mm	押側 cm ²	引側 cm ²	押側 kN	引側 kN					
SS1246K		16	102.8	91.5	43.6	38.9	4.50	4.50	8000	0.017	8.0	3.0
SS1452K		22	133.0	122.6	56.5	52.1	4.50	4.50	6500	0.031	13.0	3.9
SS1452C		22	133.0	122.6	56.5	52.1	4.50	4.50	6500	0.031	13.0	3.9
SS1453K		22	133.0	122.6	56.5	52.1	4.50	4.50	6500	0.031	13.0	3.9
SS1666K		25	165.9	153.1	70.6	65.0	4.50	4.50	5600	0.065	19.0	4.0
SS1775K		25	166.5	152.1	70.7	64.6	4.50	4.50	5500	0.061	18.5	4.2
SS1881K		25	187.1	171.9	79.5	73.1	4.50	4.50	4800	0.087	24.0	4.3
SS2110K		30	229.6	219.6	74.7	71.0	3.50	3.50	3500	0.197	37.0	6.0



**ROTARY
CYLINDER**

Compact Hydraulic Cylinder with Large Through-Hole

SS series

Accommodates BB200 and B-200 series
The compact design maximises Lathe performance

- Compact : 30% reduction in length of current S series
 - Speed Increased
 - Can operate one size larger chuck due to increased pull forces
 - Coolant collector and confirmation devices are available as an option
- *Please refer to P76 about options.
 *CE corresponding (Only series with confirmation device)



Dimensional Drawings

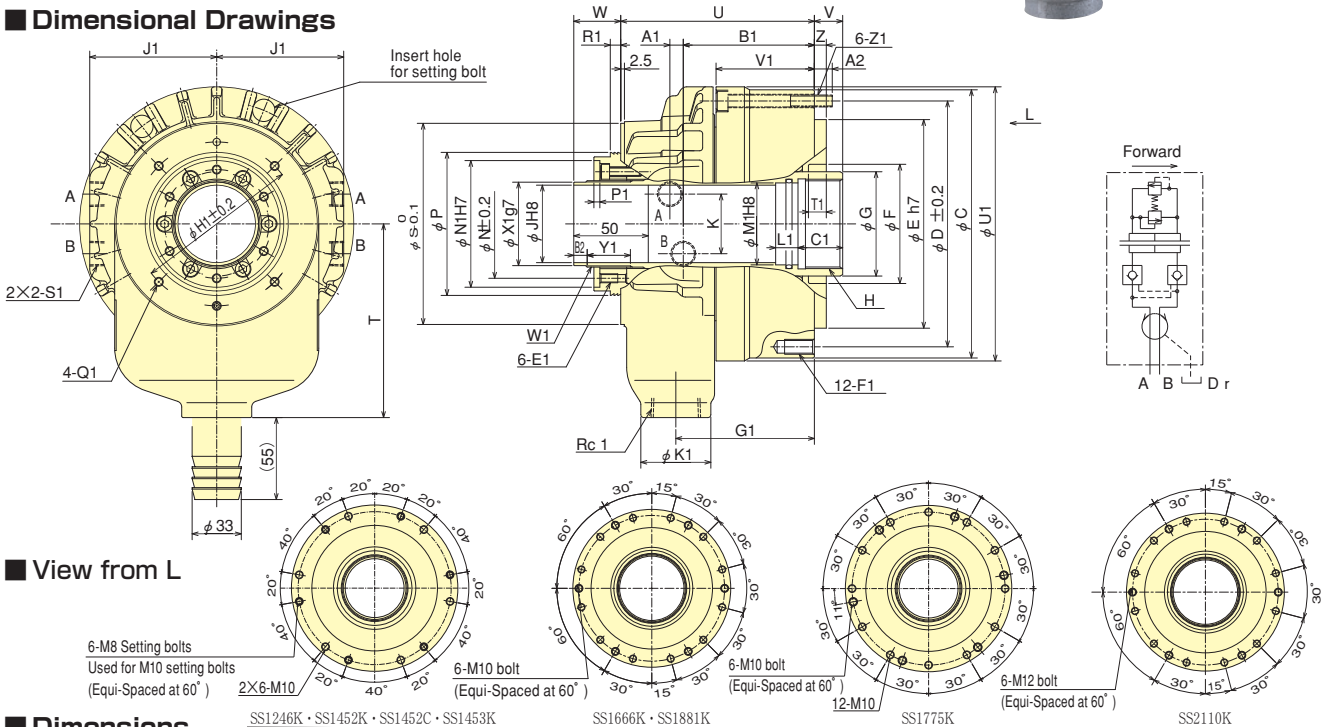

Dimensions

Dimensions		C	D	E	F	G	H	J	K	N	P	S	T	U	V	V	W	W	Z	A1	B1	C1
Model	Thru-Hole																					
SS1246K	46	162	147	130	75	65	M55×2	46	40	64	85	116	120	120	13	-3	45.0	29.0	8	8.5	79.5	25
SS1452K	52	180	165	140	80	70	M60×2	52	40	73	96	135	130	130	19	-3	53.5	31.5	8	9.0	88.0	30
SS1452C	52	180	165	140	80	70	M60×2	52	40	73	96	135	130	130	19	-3	47.0	25.0	8	9.0	88.0	30
SS1453K	53	180	165	140	80	70	M60×2	53	40	73	96	135	130	130	19	-3	53.5	31.5	8	9.0	88.0	30
SS1666K	66	207	190	168	95	85	M75×2	66	48	88	111	154	150	150	22	-3	58.0	33.0	8	13.0	99.5	35
SS1775K	75	212	195	160	105	95	M85×2	75	46	98	121	164	160	157	22	-3	57.0	32.0	8	17.5	99.0	35
SS1881K	81	222	205	168	110	100	M90×2	81	46	103	126	175	175	167	23	-2	58.0	33.0	8	17.0	106.0	35
SS2110K	106	260	240	200	135	125	M115×2	106	46	133	160	210	200	192	27	-3	64.0	34.0	8	20.0	120.5	35

Dimensions		E1 depth	F1 depth	G1	H1	J1	K1	L1	M1	N1	P1	Q1 depth	R1	S1	T1	U1	V1	W1	X1	Y1	Z1	A2	B2
SS1246K	M6×10	M10×20	84	98	76	47	15	50	76	4	M5×6	6.5	Rc ³ / ₈	12	165	57.5	M52×1.5	50.0	29	M8	15	9	
SS1452K	M6×12	M10×20	93	110	86	47	15	55	85	4	M6×6	7.0	Rc ³ / ₈	12	184	66.0	M58×1.5	56.0	30	M8	12	8	
SS1452C	M6×9.5	M10×20	93	110	86	47	15	55	85	4	M6×6	9.5	Rc ³ / ₈	12	184	66.0	M58×1.5	56.0	29	M8	12	9	
SS1453K	M6×12	M10×20	93	110	86	47	15	55	85	4	M6×6	7.0	Rc ³ / ₈	12	184	66.0	M58×1.5	56.0	30	M8	12	8	
SS1666K	M6×12	M12×24	108	145	97	47	15	70	100	4	M6×10	16.5	Rc ¹ / ₂	12	211	71.0	M74×1.5	71.5	36	M10	19	9	
SS1775K	M6×12	M10×20	110	155	100	47	15	80	108	4	M6×10	14.0	Rc ¹ / ₂	12	216	71.0	M84×2.0	81.0	33	M10	18	9	
SS1881K	M6×12	M12×24	115	166	105	47	15	85	113	4	M6×10	16.5	Rc ¹ / ₂	12	226	71.0	M89×2.0	86.0	38	M10	19	9	
SS2110K	M6×12	M12×24	130	201	124	47	15	110	145	4	M6×10	16.0	Rc ¹ / ₂	12	263	79.5	M118×2.0	115.0	45	M12	18	9	

Specifications

*Piston thrust: at Max. Operation Pressure
 *Leakage: Pressure 3.0MPa and oil temperature 50°C

Model	Piston stroke		Piston Area		Piston thrust		Max. Operation Pressure (MPa)	Max. Speed (min ⁻¹)	Moment of inertia (kg·m ²)	Net Weight (kg)	Leakage (l/min)
	mm		Push Side (cm ²)	Pull Side (cm ²)	Push Side (kN)	Pull Side (kN)					
SS1246K	16	102.8	91.5	43.6	38.9	4.50	8000	0.017	8.0	3.0	
SS1452K	22	133.0	122.6	56.5	52.1	4.50	6500	0.031	13.0	3.9	
SS1452C	22	133.0	122.6	56.5	52.1	4.50	6500	0.031	13.0	3.9	
SS1453K	22	133.0	122.6	56.5	52.1	4.50	6500	0.031	13.0	3.9	
SS1666K	25	165.9	153.1	70.6	65.0	4.50	5600	0.065	19.0	4.0	
SS1775K	25	166.5	152.1	70.7	64.6	4.50	5500	0.061	18.5	4.2	
SS1881K	25	187.1	171.9	79.5	73.1	4.50	4800	0.087	24.0	4.3	
SS2110K	30	229.6	219.6	74.7	71.0	3.50	3500	0.197	37.0	6.0	



**ROTARY
CYLINDER**

中空回転油圧シリンダ Hydraulic Cylinder with Through-Hole S series

中空のKITAGAWAスタンダードタイプ KITAGAWA standard thru-hole type



- 大きな貫通穴、小型、軽量化を実現
Compact and light-weight
- ロックバルブ、リリーフバルブ内蔵
Built-in check valve and relief valve
- クーラントコレクタや確認装置がオプションで選択可能
Coolant collector and confirmation devices are available as an option

※オプションについてはP76を参照してください。
※Please refer to P76 about options.

*CE対応品 (確認装置付のみ)
*CE corresponding (Only series with confirmation device)

■ 寸法図 Dimensional Drawings

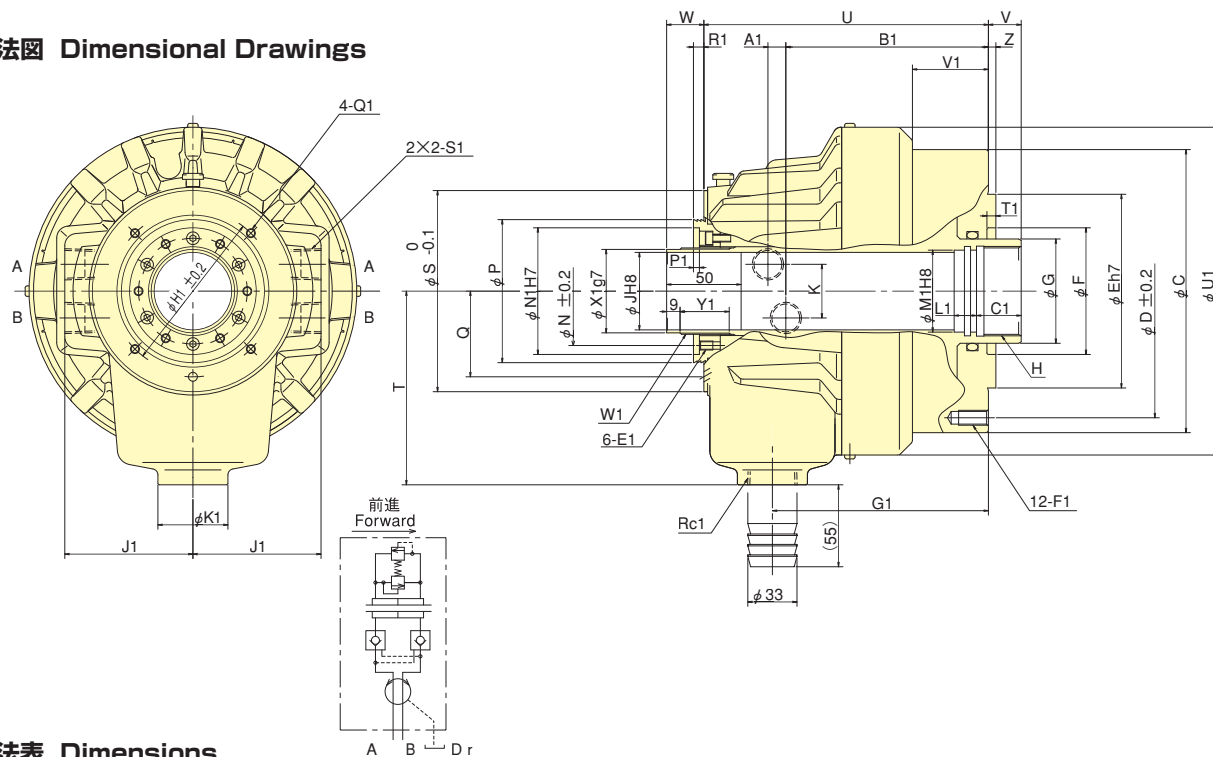

■ 寸法表 Dimensions

型式 Model	C	D	E	F	G	H	J 貫通穴 Thru-Hole	K	N	P	Q	S	T	U	V max.	V min.	W max.	W min.	Z	A ₁	B ₁
S1246	155	130	100	80	65	M 55×2.0	46	36	64	85	51.5	119.5	115	179	15	0	40	25	5	11.5	126.5
S1552	190	170	130	85	70	M 60×2.0	52	36	73	96	57.5	139.5	130	191	22	0	47	25	5	12	136
S1875	215	190	160	120	95	M 85×2.0	75	36	98	121	70.5	168	160	225	25	0	50	25	5	17.5	153.5
S2091	240	215	180	140	110	M100×2.0	91	34	108	138	79	183.5	185	248	30	0	55	25	5	21	168

型式 Model	C ₁	E ₁ 深さ depth	F ₁ 深さ depth	G ₁	H ₁	J ₁	K ₁	L ₁	M ₁	N ₁	P ₁	Q ₁ 深さ depth	R ₁	S ₁	T ₁	U ₁	V ₁	W ₁	X ₁	Y ₁
S1246	30	M6×9	M10×20	135	98	76	47	15	50	76	4	M5×10	6	Rc ¹ / ₂	6	200	46	M52×1.5	50	33
S1552	30	M6×9	M10×20	145	110	86	47	15	55	85	4	M6×12	7	Rc ¹ / ₂	6	220	51	M58×1.5	56	33
S1875	35	M6×9	M10×20	166.5	155	101	47	15	80	108	4	M6×12	7	Rc ¹ / ₂	6	242	58	M84×2.0	81	33
S2091	35	M6×14	M12×24	183	165	110	47	15	95	120	4	M6×12	7	Rc ¹ / ₂	6	267	66	M99×2.0	96	38

■ 仕様表 Specifications

※ドレン量：油圧力3.0MPa、油温50℃の時 ※ピストン推力：油圧力4.0MPa
※Leakage: Pressure 3.0MPa and oil temperature 50℃. ※Piston thrust: Pressure 4.0MPa

型式 Model	ピストンストローク Piston stroke mm	ピストン表面積 Piston Area cm ²	ピストン推力 Piston thrust kN	最高使用油圧力 Max. Operation Pressure MPa	許容最高回転速度 Max. Speed min ⁻¹	慣性モーメント Moment of Inertia kg·m ²	質量 Net Weight kg	ドレン量 Leakage ℓ/min
S1246	15	100	38.0	4.0	7000	0.019	12.0	3.0
S1552	22	161	60.0	4.0	6200	0.053	16.8	3.9
S1875	25	198	74.0	4.0	4700	0.095	26.0	4.2
S2091	30	252	94.0	4.0	3800	0.153	33.0	4.5



ROTARY CYLINDER

中空回転油圧シリンダ (ロングストローク) Hydraulic Cylinder with Through-Hole and Long Stroke S-L series

中空のKITAGAWAスタンダードタイプ KITAGAWA standard thru-hole type



- ロングストロークタイプ
Long piston stroke
- ロックバルブ、リリーフバルブ内蔵
Built-in check valve and relief valve
- クーラントコレクタや確認装置がオプションで選択可能
Coolant collector and confirmation devices are available as an option

※オプションについてはP76を参照してください。
※Please refer to P76 about options.

*CE対応品 (確認装置付のみ)
*CE corresponding (Only series with confirmation device)

■ 寸法図 Dimensional Drawings

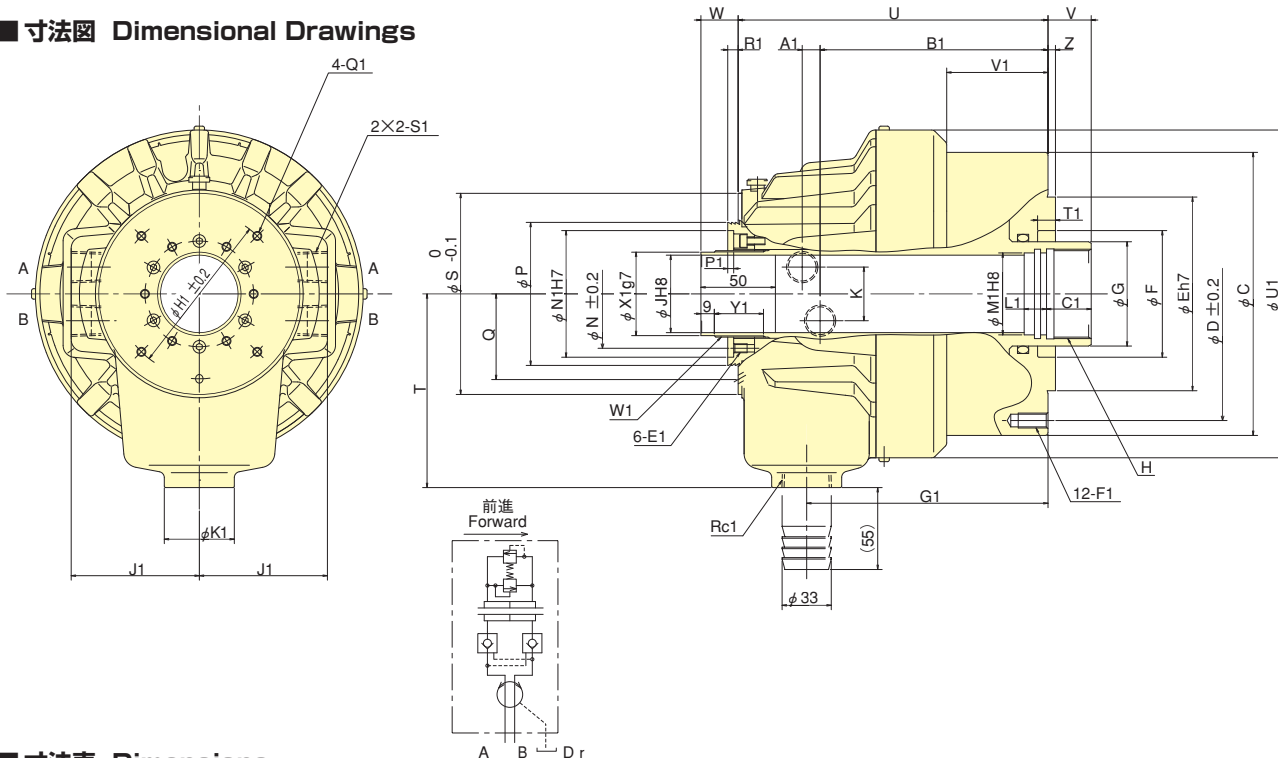

■ 寸法表 Dimensions

寸法 Dimensions Model	C	D	E	F	G	H	J 貫通穴 Thru-Hole	K	N	P	Q	S	T	U	V max.	V min.	W max.	W min.	Z	A1	B1
S1246L	155	130	100	80	65	M55×2.0	46	36	64	85	51.5	119.5	115	200	27	-5	57	25	5	11.5	147.5
S1552L	190	170	130	85	70	M60×2.0	52	36	73	96	57.5	139.5	130	208	29	-5	59	25	5	12	153
S1875L	215	190	160	120	95	M85×2.0	75	36	98	121	70.5	168	160	241	35	-5	65	25	5	17.5	169.5
S2091L	240	215	180	140	110	M100×2.0	91	34	108	138	79	183.5	185	268	45	-5	75	25	5	21	188

寸法 Dimensions Model	C1	E1 深さ depth	F1 深さ depth	G1	H1	J1	K1	L1	M1	N1	P1	Q1 深さ depth	R1	S1	T1	U1	V1	W1	X1	Y1
S1246L	30	M6×9	M10×20	156	98	76	47	15	50	76	4	M5×10	6	Rc1/2	12	200	67	M52×1.5	50	33
S1552L	30	M6×9	M10×20	162	110	86	47	15	55	85	4	M6×12	7	Rc1/2	12	220	68	M58×1.5	56	33
S1875L	35	M6×9	M10×20	182.5	155	101	47	15	80	108	4	M6×12	7	Rc1/2	12	242	74	M84×2.0	81	33
S2091L	35	M6×14	M12×24	203	165	110	47	15	95	120	4	M6×12	7	Rc1/2	12	267	86	M99×2.0	96	38

■ 仕様表 Specifications

※ドレン量：油圧力3.0MPa、油温50℃の時 ※ピストン推力：油圧力4.0MPa
※Leakage: Pressure 3.0MPa and oil temperature 50℃. ※Piston thrust: Pressure 4.0MPa

仕様 Specifications Model	ピストンストローク Piston stroke mm	ピストン表面積 Piston Area cm ²	ピストン推力 Piston thrust kN	最高使用油圧力 Max. Operation Pressure MPa	許容最高回転速度 Max. Speed min ⁻¹	慣性モーメント Moment of inertia kg·m ²	質量 Net Weight kg	ドレン量 Leakage ℓ/min
S1246L	32	100	38.0	4.0	7000	0.022	12.8	3.0
S1552L	34	161	60.0	4.0	6200	0.058	17.0	3.9
S1875L	40	198	74.0	4.0	4700	0.100	26.8	4.2
S2091L	50	252	94.0	4.0	3800	0.160	34.1	4.5

回転油圧
Cylinder



ROTARY CYLINDER

中空回転油圧シリンダ High-Speed Hydraulic Cylinder with Through-Hole F series

中空のKITAGAWAスタンダードタイプ KITAGAWA standard thru-hole type

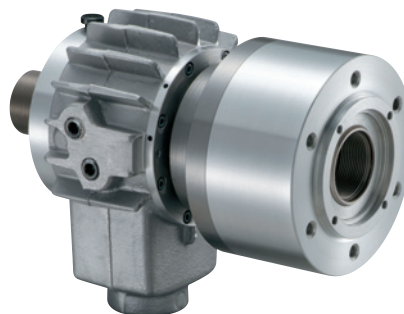

- ロックバルブ、リリーフバルブ内蔵
Built-in check valve and relief valve
- クーラントコレクタや確認装置がオプションで選択可能
Coolant collector and confirmation devices are available as an option

※オプションについてはP76を参照してください。
※Please refer to P76 about options.

※CE対応品（確認装置付のみ）
※CE corresponding (Only series with confirmation device)

■ 寸法図 Dimensional Drawings

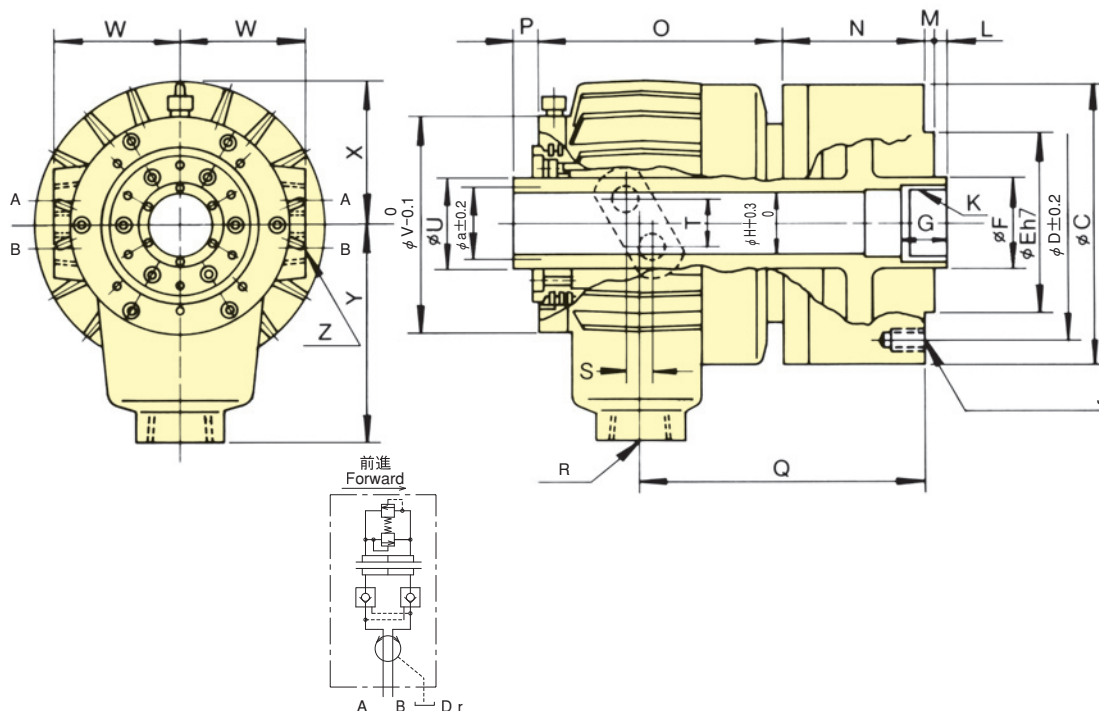

■ 寸法表 Dimensions

寸法 型式 Model	C	D	E (h7)	F	G	H 貫通穴 Thru-Hole	J 深さ depth	K	L max.	L min.	M	N	O	P max.	P min.	Q	R	S	T	U	V	W	X	Y	Z	a
F0933H	125	100	80	45	25	33.5	6-M 8×15	M 38×1.5	7	5	5	71	119	41	29	142	Rc ³ /4	11.8	22	M39×1.5	104	64	66	110	2×2-Rc ¹ /4	-
F2511H	310	275	230	140	45	117.5	12-M 16×32	M 130×2.0	18	5	6	101	209	38	15	217	Rc 1	27	20	1346	232	131	135.5	215	2×2-Rc ³ /8	127

※ドレン量：油圧力3.0MPa、油温50℃の時 ※ピストン推力：油圧力4.0MPa
※Leakage: Pressure 3.0MPa and oil temperature 50℃. ※Piston thrust: Pressure 4.0MPa

■ 仕様表 Specifications

仕様 型式 Model	ピストンストローク Piston stroke mm	ピストン表面積 Piston Area cm ²	ピストン推力 Piston thrust kN	最高使用油圧力 Max. Operation Pressure MPa	ドレン量 Leakage ℓ/min	許容最高回転速度 Max. Speed min ⁻¹	質量 Net Weight kg	慣性モーメント Moment of inertia kg·m ²
F0933H	12	58	22.0	4.0	3.0	8000	8.5	0.008
F2511H	23	348	125.0	4.0	7.0	2800	60.0	0.445



ROTARY CYLINDER

クーラントコレクタ・確認装置 Coolant Collector Confirmation Device

■ 寸法図 Dimensional Drawings

クーラントコレクタ・ディテクタブルプレート付き
Coolant Collector with Detectable Plate

クーラントコレクタ・ディテクタブルプレートなし
Coolant Collector without Detectable Plate

近接スイッチは付属していません。
お客様の制御装置に合わせて、寸法図を
参考にご用意願います。

The proximity switch is optional.
Determine the appropriate type
according to the controller type
and dimension drawing.

ディテクタブルプレートは付属して
いません。ディテクタブルプレートが必要な
場合、弊社の担当営業員までお問い合わせ
ください。

Detectable plate is optional. If
you need it, please consult us.

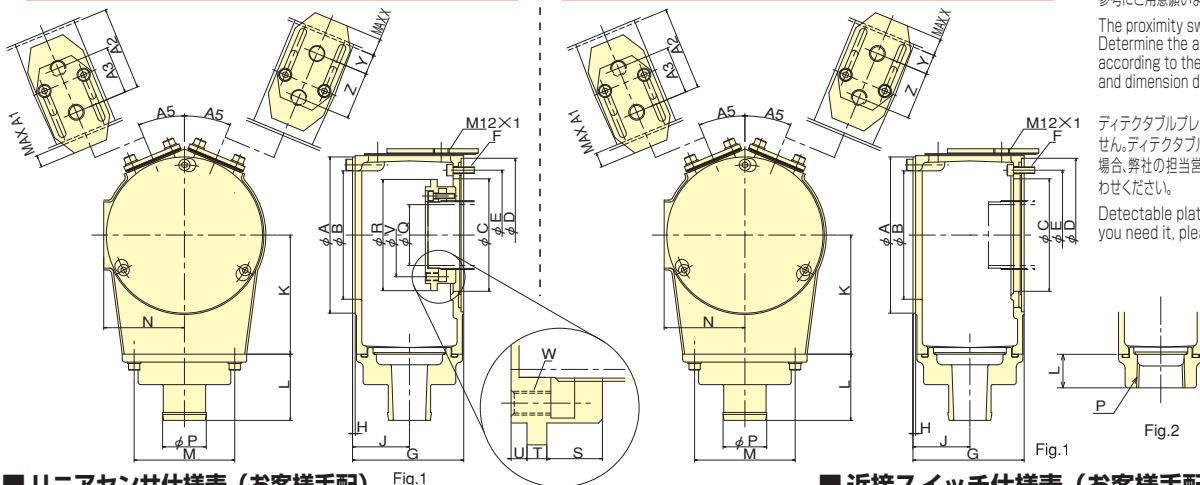

Fig.1

Fig.1

Fig.2

■ リニアセンサ仕様表 (お客様手配)

Linear sensor Specifications (Customer arrangement)

メーカー Manufacturer	バルーフ株式会社 Balluff Ltd.
型式 Model	BIP AD2-T030-02-S4
出力信号 Output signal	0~10V
測定範囲 Measurement range	0~30mm
接続 Connection	M12コネクタ M12 connector
検出距離 Detection distance	1~3mm
電源電圧 Power supply - Voltage	DC15~30V
使用周囲温度 Ambient operating temperature	-25℃~+85℃
保護等級 Protection rating	IP67
繰返し精度 Repeatability	±100μm

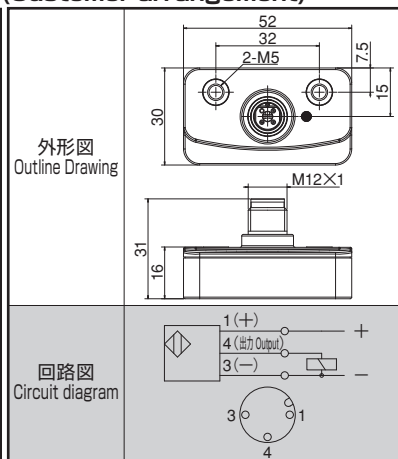

■ 近接スイッチ仕様表 (お客様手配)

Proximity switch Specifications (Customer arrangement)

メーカー Manufacturer	バルーフ株式会社 Balluff Ltd.	アズビル株式会社 Azbil Corporation
型式 Model	BES M12MI-NSC20B-BV02	FL7M-3J6HD
出力形式 Output form	N.O.(ノーマルオープン) N.O.(Normal Open)	N.O.(ノーマルオープン) N.O.(Normal Open)
センサヘッド形状 Sensor head form	M12×1	M12×1
定格動作距離 Rated operating distance	2mm	3mm
電源電圧 Power supply - Voltage	DC10~30V	DC10~30V
使用周囲温度 Ambient operating temperature	-25~+70℃	-25~+70℃
保護等級 Protection rating	IP68	IP67
回路図 Circuit diagram		

*機械メーカー様によってはリニアセンサ仕様表が使用できない場合があります。機械メーカー様へご確認ください。

*Linear sensor specifications may not be available depending on the machine manufacturer. Please confirm with the manufacture.

■ 寸法表 Dimensions

*CSK12, CSK14, CSK16, CSK17, CSK18, CSK21とCS-25Hのアンダーボデー部形状はFig.2参照
*The under bodies of CSK12, CSK14, CSK16, CSK17, CSK18, CSK21 and CS-25H are based on Fig.2.

型式 Model	適用シリンダ Matching Cylinder	A	B	C	D	E	F	G	H	J	K	L	M	N	P	Q
CS-S10	S1036	118	97	73	104	88	4-M5	84	2	43	90	50	76	61	33	36
CS-S12	S1246(L)	118	97	85	116	98	4-M5	84	2	43	90	50	76	61	33	46
CS-S15	S1552(L)	136	114	96	135	110	4-M6	84	2	43	100	50	76	71	33	52
CS-S18	S1875(L)	181	154	121	164	155	4-M6	88	2	46	140	50	76	94	33	75
CS-S20	S2091(L)	181	154	138	180	165	4-M6	104	2	44	140	50	76	94	33	91
CSK12	SS1246K	118	97	85	116	98	4-M5	62	2	32	90	23	76	61	Rc 1	46
CSK14	SS1453K	136	114	96	135	110	4-M6	84	2	35	100	23	76	71	Rc 1	53
CSK16	SS1666K	171	144	111	154	145	4-M6	88	2	38	135	23	76	89	Rc 1	66
CSK17	SS1775K	181	154	121	164	155	4-M6	84	2	50.5	140	23	76	94	Rc 1	75
CSK18	SS1881K	191	165	126	175	166	4-M6	88	2	38	145	23	76	99	Rc 1	81
CSK21	SS2110K	229	200	160	210	201	4-M6	84	2	35	163	23	76	118	Rc 1	106
CS-F08	F0933H	118	97	73	104	88	4-M5	84	2	43	90	50	76	61	26	33
CS-25H	F2511H	232	200	179	-	206	4-M6	101.6	1.6	51.6	180	-	-	119	Rc3/4	117.5

型式 Model	適用シリンダ Matching Cylinder	R	S	T	U	V	W	X max.	Y	Z	A1 max.	A2	A3	A5	ディテクタブルプレート Detectable plate
CS-S10	S1036	84	14	5	4	52	4-M6	13	15	36	9	63	36	22.5°	61R326543
CS-S12	S1246(L)	84	14	5	4	63	4-M6	13	15	36	9	63	36	22.5°	61R324821
CS-S15	S1552(L)	99	14	5	4	70	4-M6	13	15	36	9	63	36	22.5°	61R324822
CS-S18	S1875(L)	144	14	5	4	95	4-M6	15	15	39	15	71	39	15°	61R324823
CS-S20	S2091(L)	144	21	5	2	108	4-M6	8	22	41	10	82	41	15°	61R324824
CSK12	SS1246K	84	10	5	8	63	4-M6	10	15	27	7	42	27	22.5°	61R801796
CSK14	SS1453K	99	4	5	11.5	70	4-M6	13	15	36	10	64	37	20°	61R384150
CSK16	SS1666K	134	12.5	5	4	85.5	4-M6	8	15	28	7	70	28	15°	61R384152
CSK17	SS1775K	144	14	5	4	95	4-M6	13.5	14.5	32.5	13.5	54.5	32.5	15°	61R324823
CSK18	SS1881K	155	12.5	5	4	100	4-M6	8	15	28	7	70	28	15°	61R387994
CSK21	SS2110K	190	14	5	4	130	4-M6	13	15	24	9	63	24	12°	61R367982
CS-F08	F0933H	72	25	7	-	-	-	13	15	36	9	63	36	22.5°	61R328668
CS-25H	F2511H	192	12	12	-	-	-	18	17	52	11.4	85	36	22.5°	61R310094

回転
Cylinder



ROTARY
CYLINDER

短寸中実回転油圧シリンダ

M series

短寸、小型、軽量

ロックバルブ、リリーフバルブ内蔵、さらに近接スイッチ取付可能仕様



近接スイッチは付属していません。
お客様の制御装置に合わせて、寸法図を参考に
ご用意願います。

- 超小型、軽量化を追求しました
 - ロックバルブ、リリーフバルブ内蔵、さらに近接スイッチ取付可能仕様
- *CE対応品

■寸法図

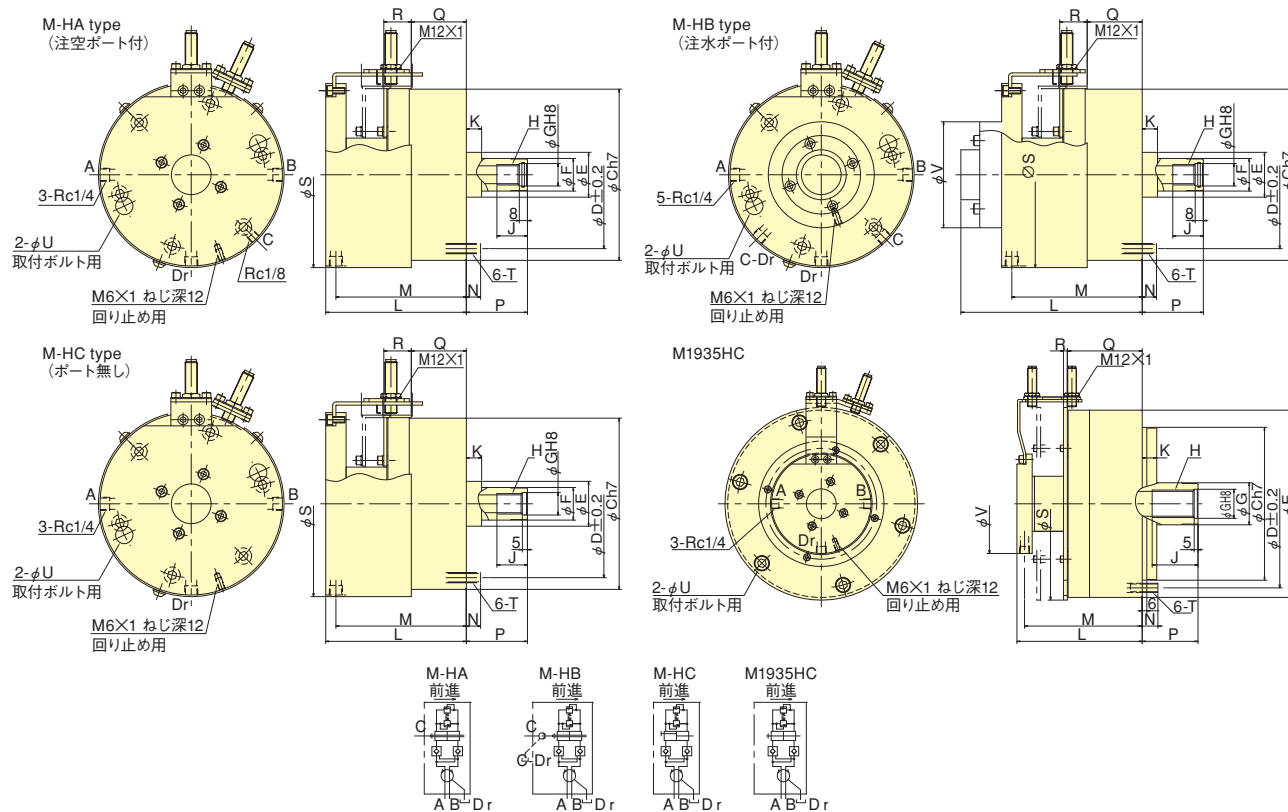

■寸法表

寸法	C (h7)		D	E	F	G (H8)		H	J	K	L	M	N	P max.	P min.	Q max.	Q min.	R	S	T	U	V
M1120HA21D	145	128	42	30	22	M20	30	15	135	125	14	60	40	72	52	26	159.2	M 8	14	-	-	
M1120HB21N	145	128	42	30	22	M20	30	15	175	125	14	60	40	72	52	26	159.2	M 8	14	104	-	
M1120HC21D	145	128	42	30	22	M20	30	15	135	125	14	60	40	72	52	26	159.2	M 8	14	-	-	
M1221HA21D	168	145	44	32	22	M20	30	15	138	128	14	60	39	75	54	27	182.2	M10	17	-	-	
M1221HB21N	168	145	44	32	22	M20	30	15	178	128	14	60	39	75	54	27	182.2	M10	17	104	-	
M1221HC21D	168	145	44	32	22	M20	30	15	138	128	14	60	39	75	54	27	182.2	M10	17	-	-	
M1330HA21D	168	150	51	36	26	M24	35	15	144	134	18	60	30	79	49	37	182.2	M10	17	-	-	
M1330HB21N	168	150	51	36	26	M24	35	15	184	134	18	60	30	79	49	37	182.2	M10	17	104	-	
M1330HC21D	168	150	51	36	26	M24	35	15	144	134	18	60	30	79	49	37	182.2	M10	17	-	-	
M1935HC	200	220	245	55	38	M36	60	19	164	154	20.5	73	38	133	98	5	252	M12	20	130	-	

■仕様表

*ピストン推力：最高使用油圧力M1120H \hat{H} 3.5MPa、M1221H \hat{H} 4.0MPa、M1330H \hat{H} 4.0MPa
*ドレン量は油圧3.0MPa、油温50℃の時 ※近接スイッチ：Model BES M12MI-PSC20B-BV02(バルブ付)DC24V 200mA PNP

仕様	ピストン ストローク mm	ピストン表面積		ピストン推力		最高使用油圧力 MPa	ドレン量 ℓ/min	許容最高回転速度 min ⁻¹	質量 kg	慣性モーメント kg·m ²
		押側 cm ²	引側 cm ²	押側 kN	引側 kN					
M1120HA21D	20	87.6	84	28.0	27.0	3.5	1.2	6000	8.2	0.016
M1120HB21N	20	87.6	84	28.0	27.0	3.5	1.2	6000	8.5	0.016
M1120HC21D	20	87.6	84	28.0	27.0	3.5	1.2	6000	8.2	0.016
M1221HA21D	21	105.7	102	39.0	38.0	4.0	1.2	6000	10.2	0.028
M1221HB21N	21	105.7	102	39.0	38.0	4.0	1.2	6000	10.5	0.028
M1221HC21D	21	105.7	102	39.0	38.0	4.0	1.2	6000	10.2	0.028
M1330HA21D	30	125.3	119	47.0	45.0	4.0	1.2	6000	10.3	0.029
M1330HB21N	30	125.3	119	47.0	45.0	4.0	1.2	6000	10.6	0.029
M1330HC21D	30	125.3	119	47.0	45.0	4.0	1.2	6000	10.3	0.029
M1935HC	35	274	252	103	94.6	4.0	1.2	6000	23	0.15



**ROTARY
CYLINDER**

Compact Hydraulic Cylinder with Non-Through-Hole

M series



Short, Compact, and Light
Built-in check valve and pressure relief valve,
and proximity switches can be attached

- Compact and lightweight
 - Built-in check valve and pressure relief valve, and proximity switches can be attached
- *CE corresponding

The proximity switch is optional.
Determine the appropriate type according to the controller type and dimension drawing.

Dimensional Drawings

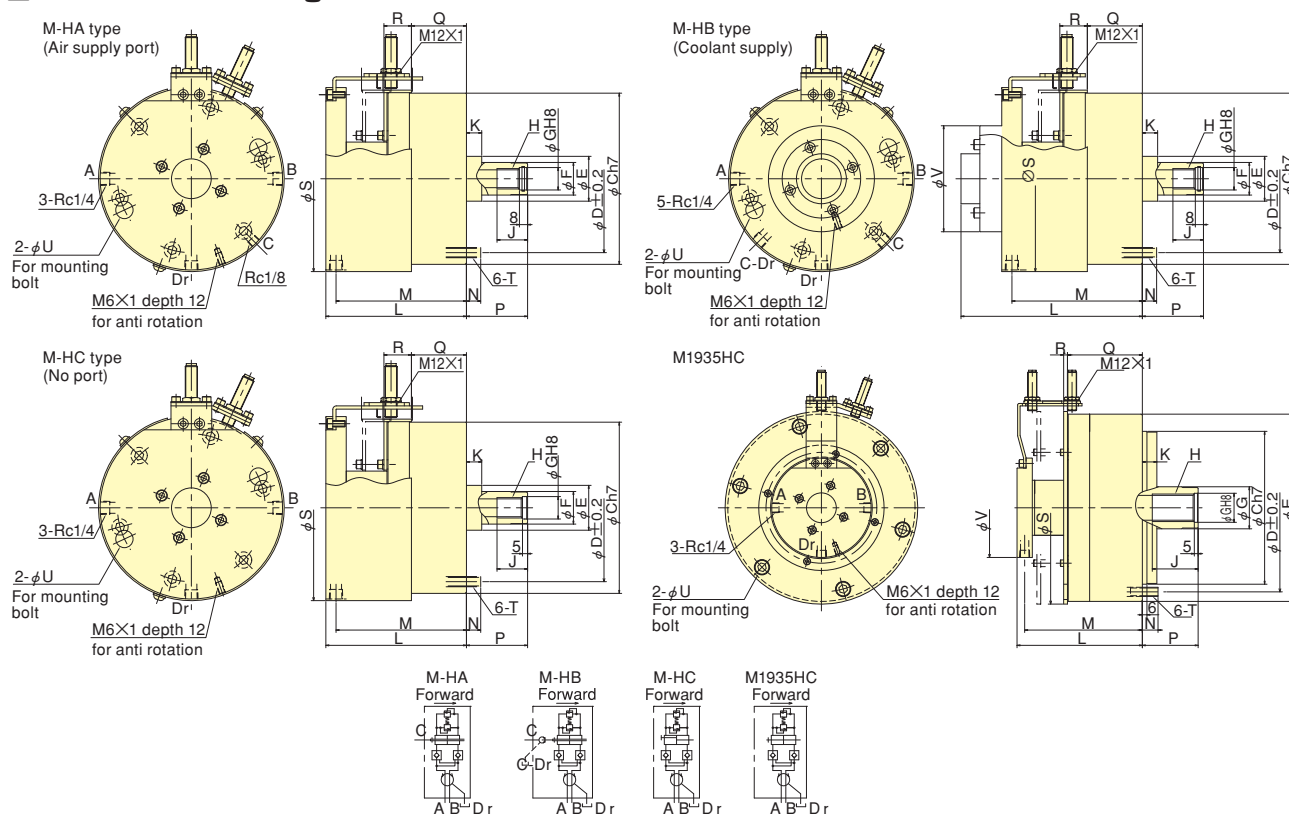

コンパクト
シリンダー

Dimensions

Model	Dimensions (C (h7))	D	E	F	G (H8)	H	J	K	L	M	N	P max.	P min.	Q max.	Q min.	R	S	T	U	V
M1120HA21D	145	128	42	30	22	M20	30	15	135	125	14	60	40	72	52	26	1592	M 8	14	-
M1120HB21N	145	128	42	30	22	M20	30	15	175	125	14	60	40	72	52	26	1592	M 8	14	104
M1120HC21D	145	128	42	30	22	M20	30	15	135	125	14	60	40	72	52	26	1592	M 8	14	-
M1221HA21D	168	145	44	32	22	M20	30	15	138	128	14	60	39	75	54	27	1822	M10	17	-
M1221HB21N	168	145	44	32	22	M20	30	15	178	128	14	60	39	75	54	27	1822	M10	17	104
M1221HC21D	168	145	44	32	22	M20	30	15	138	128	14	60	39	75	54	27	1822	M10	17	-
M1330HA21D	168	150	51	36	26	M24	35	15	144	134	18	60	30	79	49	37	1822	M10	17	-
M1330HB21N	168	150	51	36	26	M24	35	15	184	134	18	60	30	79	49	37	1822	M10	17	104
M1330HC21D	168	150	51	36	26	M24	35	15	144	134	18	60	30	79	49	37	1822	M10	17	-
M1935HC	200	220	245	55	38	M36	60	19	164	154	20.5	73	38	133	98	5	252	M12	20	130

*Piston thrust : Max. Operation Pressure M1120H 3.5MPa, M1221H 4.0MPa, M1330H 4.0MPa
*Leakage : Pressure 3.0MPa and oil temperature 50°C. *Proximity switch : Model BES M12MI-PSC20B-BV02 (manufactured by Balluff) DC24V 200mA PNP

Specifications

Model	Piston stroke mm	Piston Area Push Side cm ²	Piston Area Pull Side cm ²	Piston thrust Push Side kN	Piston thrust Pull Side kN	Max. Operation Pressure MPa	Leakage ℓ / min	Max. Speed min ⁻¹	Net Weight kg	Moment of inertia kg·m ²
M1120HA21D	20	87.6	84	28.0	27.0	3.5	1.2	6000	8.2	0.016
M1120HB21N	20	87.6	84	28.0	27.0	3.5	1.2	6000	8.5	0.016
M1120HC21D	20	87.6	84	28.0	27.0	3.5	1.2	6000	8.2	0.016
M1221HA21D	21	105.7	102	39.0	38.0	4.0	1.2	6000	10.2	0.028
M1221HB21N	21	105.7	102	39.0	38.0	4.0	1.2	6000	10.5	0.028
M1221HC21D	21	105.7	102	39.0	38.0	4.0	1.2	6000	10.2	0.028
M1330HA21D	30	125.3	119	47.0	45.0	4.0	1.2	6000	10.3	0.029
M1330HB21N	30	125.3	119	47.0	45.0	4.0	1.2	6000	10.6	0.029
M1330HC21D	30	125.3	119	47.0	45.0	4.0	1.2	6000	10.3	0.029
M1935HC	35	274	252	103	94.6	4.0	1.2	6000	23	0.15



**ROTARY
CYLINDER**

中実回転油圧シリンダ Hydraulic Cylinder with Non-Through-Hole Y-R series

中実のKITAGAWAスタンダードタイプ KITAGAWA standard non-through-hole type

- ロックバルブ、リリーフバルブ内蔵の安全構造
Built in safety check valves and pressure relief valves

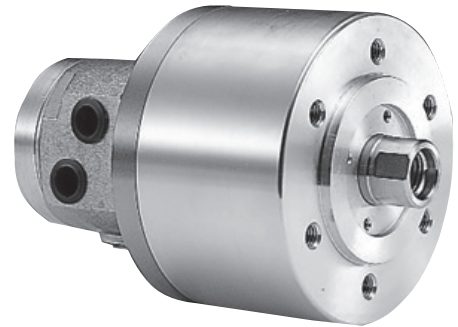

■ 寸法図 Dimensional Drawings

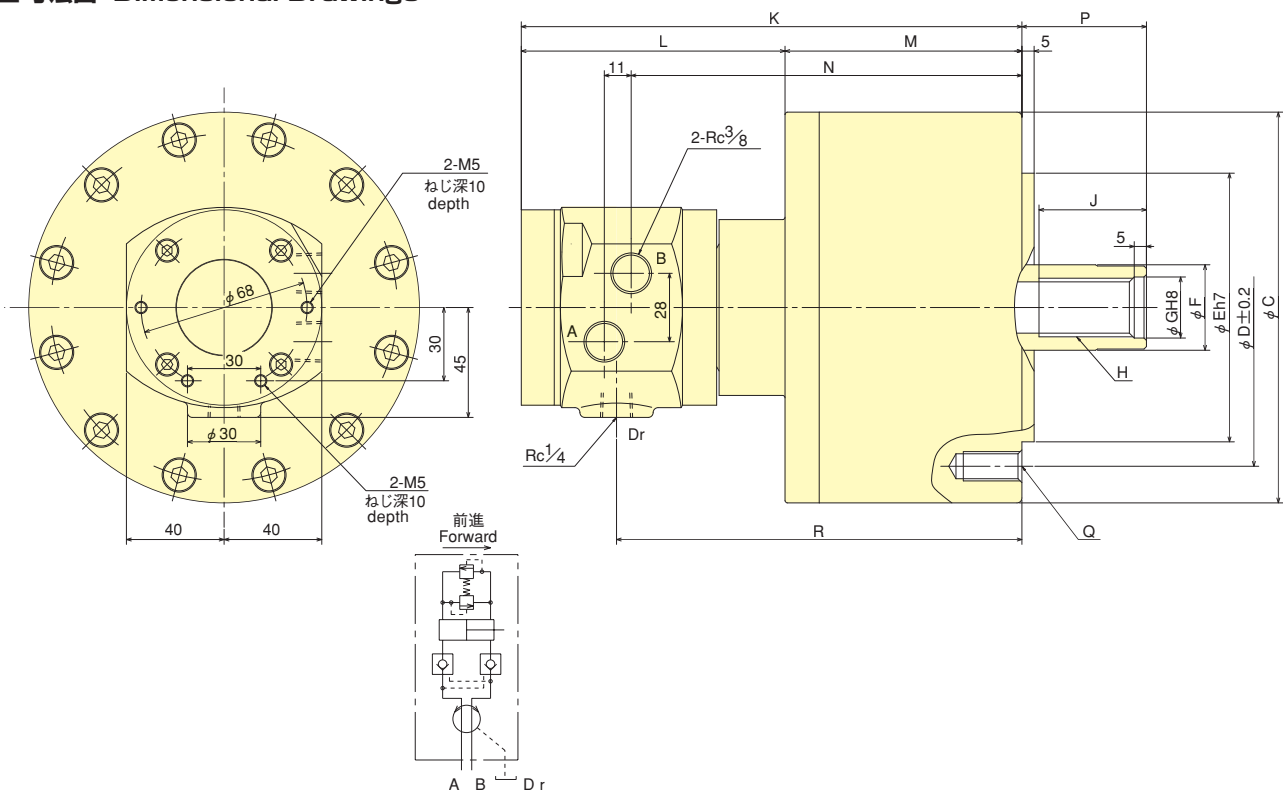

■ 寸法表 Dimensions

型式 Model	C	D	E	F	G	H	J	K	L	M	N	P max.	P min.	Q 深さ depth	R
Y0715R	104	90	65	30	21	M20	35	172	106	66	127	46	31	6-M 6×20	133
Y1020R	135	100	80	30	21	M20	35	197	108	89	152	45	25	6-M10×20	158
Y1225R	160	130	110	35	25	M24	44	205	108	97	160	51	26	6-M12×24	166
Y1530R	190	130	110	45	31	M30	45	214	108	106	169	56	26	12-M12×24	175
Y2035R	245	145	120	55	37	M36	60	228	106	122	183	69	34	12-M16×30	189

■ 仕様表 Specifications

※ピストン推力：油圧力4.0MPa ※ドレン量は油圧力3.0MPa、油温50℃の時
 ※Piston thrust: Pressure 4.0MPa ※Leakage: 3.0MPa and oil temperature 50℃.

型式 Model	ピストンストローク Piston stroke mm	ピストン表面積 Piston Area cm ²	ピストン推力 Piston thrust kN	最高使用油圧力 Max. Operation Pressure MPa	ドレン量 Leakage ℓ/min	許容最高回転速度 Max. Speed min ⁻¹	質量 Net Weight kg	慣性モーメント Moment of inertia kg·m ²
Y0715R	15	44	16.6	4.0	0.8	6000	4.0	0.003
Y1020R	20	86	32.0	4.0	0.8	6000	7.1	0.013
Y1225R	25	122	46.0	4.0	0.8	6000	10.0	0.023
Y1530R	30	176	66.0	4.0	0.8	5500	13.5	0.048
Y2035R	35	314	117.0	4.0	0.8	5500	22.0	0.098



ROTARY CYLINDER

中実回転油圧シリンダ (近接スイッチ取付可能仕様) Hydraulic Cylinder with Non-Through-Hole (proximity switches can be attached) **Y-RE series**

**中実のKITAGAWAスタンダードタイプ
KITAGAWA standard non-through-hole type
ストローク確認可能仕様でさらに安心
Stroke position can be confirmed**

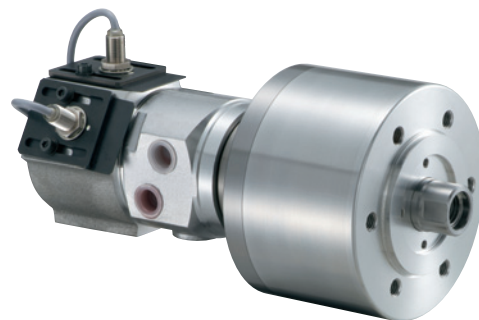

- ロックバルブ、リリーフバルブ内蔵
Built-in check valve and relief valve
 - リニアセンサ取付可能 (オプション)
Linear sensor switches can be attached (option)
- ※機械メーカーによってはリニアセンサ仕様が使用できない場合があります。機械メーカーへご確認ください。
※Linear sensor specifications may not be available depending on the machine manufacturer. Please confirm with the manufacturer.
*CE対応品 *CE corresponding

近接スイッチは付属していません。
お客様の制御装置に合わせて、寸法図を参考にをご用意願います。
The proximity switch is optional.
Determine the appropriate type according to the controller type and dimension drawing.

■ 寸法図 Dimensional Drawings

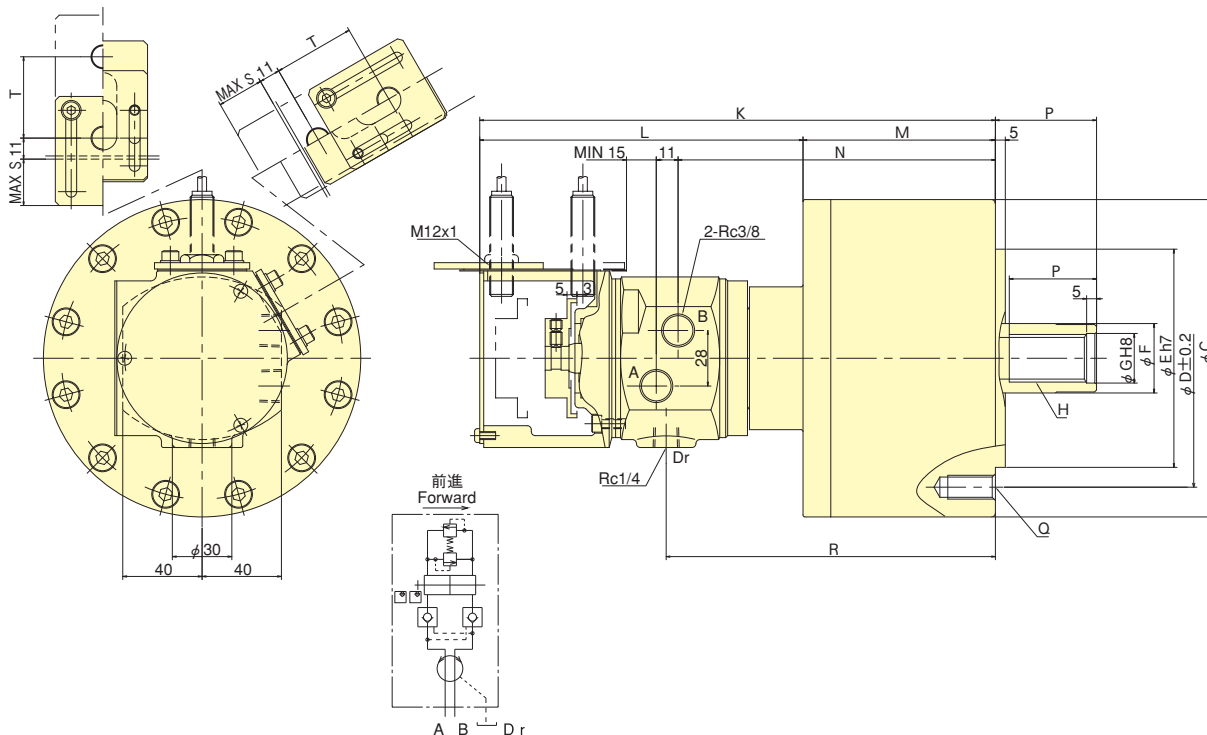

■ 寸法表 Dimensions

型式 Model	C	D	E	F	G	H	J	K	L	M	N	P max.	P min.	Q 深さ depth	R	S	T
Y0715RE01C	104	90	65	30	21	M20	32	227	161	66	127	46	31	6-M 6×20	133	23	41
Y1020RE47	135	100	80	30	21	M20	35	252	163	89	152	45	25	6-M10×20	158	23	41
Y1225RE47	160	130	110	35	25	M24	44	260	163	97	160	51	26	6-M12×24	166	23	41
Y1530RE47	190	130	110	45	31	M30	45	269	163	106	169	56	26	12-M12×24	175	23	41
Y2035RE47	245	145	120	55	37	M36	60	288	166	122	183	69	34	12-M16×30	189	28	46

■ 仕様表 Specifications

※ピストン推力：油圧力4.0MPa ※ドレン量は油圧力3.0MPa、油温50℃の時
※Piston thrust : Pressure 4.0MPa ※Leakage : 3.0MPa and oil temperature 50℃.

型式 Model	ピストンストローク Piston stroke mm	ピストン表面積 Piston Area cm ²	ピストン推力 Piston thrust kN	最高使用油圧力 Max. Operation Pressure MPa	ドレン量 Leakage ℓ/min	許容最高回転速度 Max. Speed min ⁻¹	質量 Net Weight kg	慣性モーメント Moment of inertia kg·m ²
Y0715RE01C	15	42	15.9	4.0	0.8	6000	4.5	0.003
Y1020RE47	20	84	31.0	4.0	0.8	6000	7.6	0.013
Y1225RE47	25	120	45.0	4.0	0.8	6000	10.5	0.023
Y1530RE47	30	174	65.0	4.0	0.8	5500	14.0	0.048
Y2035RE47	35	312	117.0	4.0	0.8	5500	22.5	0.098



**ROTARY
CYLINDER**

中実回転油圧ダブルシリンダ Tandem Cylinder YW-R series

HWシリーズチャックに最適 Best suited for HW-series chucks

- YW-R ロックバルブ、リリーフバルブ付き
Built-in check valve and pressure relief valve
 - YW-RE ロックバルブ、リリーフバルブ、近接スイッチ付き
Built-in check valve, pressure valve and proximity switches
- *YW-REのみ、CE対応品
*CE corresponding (YW-RE)

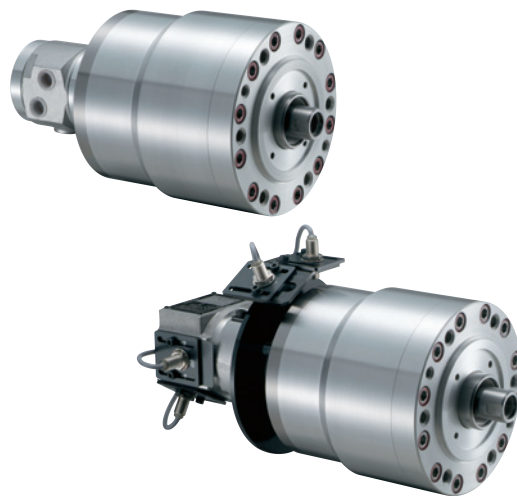

■ 寸法図 Dimensional Drawings

YW-R type

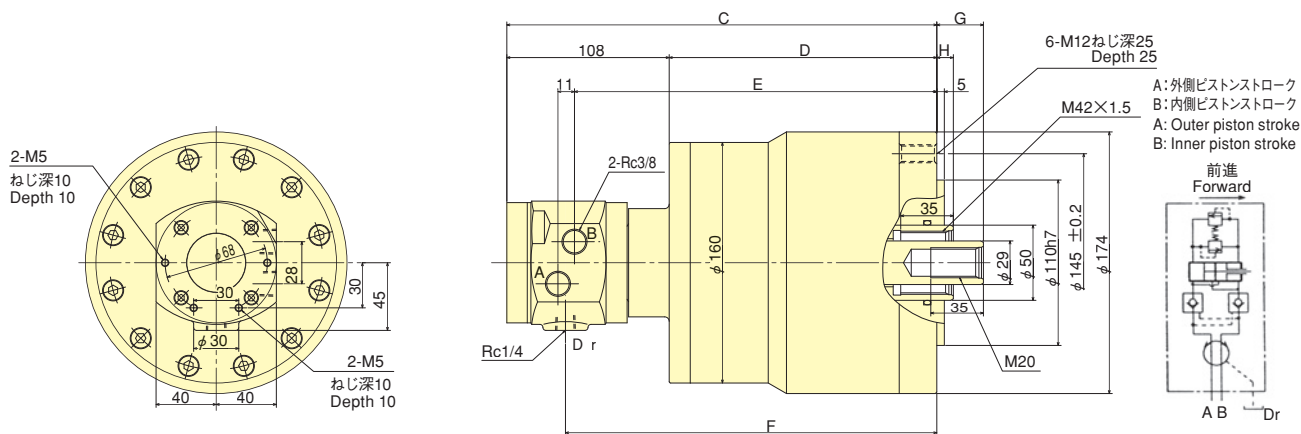

YW-RE type

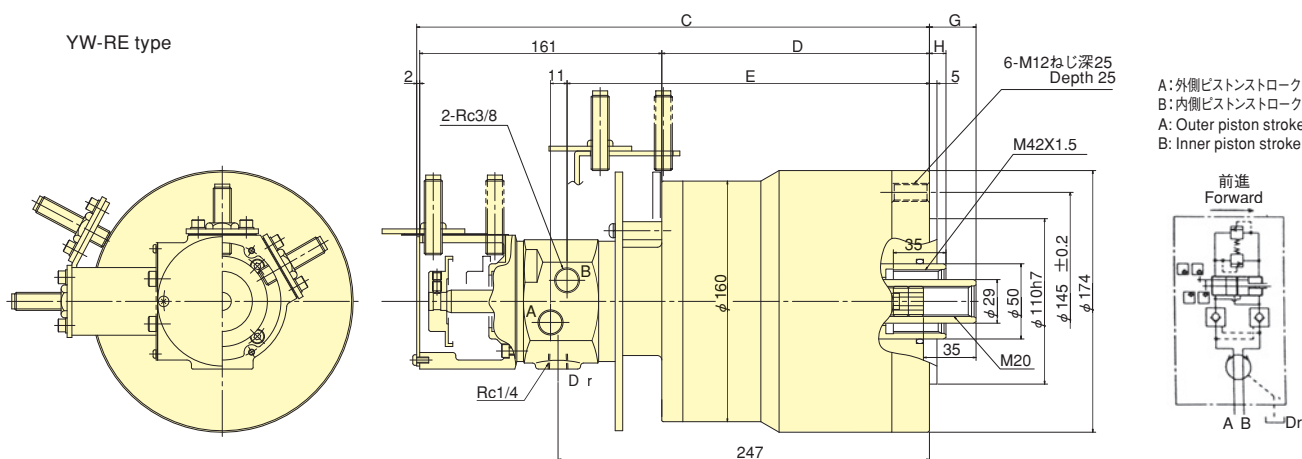

■ 寸法表 Dimensions

寸法 型式 Model	A	B	C	D	E	F	G max.	G min.	H max.	H min.
YW1220R	20	20	276	168	231	237	61	41	36	16
YW1225R	25	25	286	178	241	247	56	31	36	11
YW1220RE	20	20	331	168	231	237	61	41	36	16
YW1225RE	25	25	341	178	241	247	56	31	36	11

■ 仕様表 Specifications

*ピストン推力: 油圧力3.0MPa ※ドレン量は油圧力3.0MPa、油温50℃の時
*Piston thrust: Pressure 3.0MPa ※Leakage: 3.0MPa and oil temperature 50℃.

仕様 型式 Model	ピストンストローク Piston stroke mm	ピストン表面積 Piston Area cm ²	ピストン推力 Piston thrust kN	最高使用油圧力 Max. Operation Pressure MPa	ドレン量 Leakage ℓ/min	許容最高回転速度 Max. Speed min ⁻¹	質量 Net Weight kg	慣性モーメント Moment of inertia kg·m ²
YW1220R	20	126	33.0	3.0	0.7	5000	15.3	0.043
YW1225R	25	126	33.0	3.0	0.7	5000	15.5	0.044
YW1220RE	20	123	32.0	3.0	0.7	5000	16.3	0.044
YW1225RE	25	123	32.0	3.0	0.7	5000	16.5	0.045



**ROTARY
CYLINDER**

中実回転エアシリンダ

High-Speed Air Cylinder with Non-Through-Hole

AY-R series

歪み易い薄肉ワークに最適

Ideally for extremely thin walled work-pieces

●低推力でも確実な動作!

Secure operation even at low thrust

歪みやすい薄肉ワーク加工に最適なエアシリンダ

Air cylinder for machining easily deformed thin work-pieces



■ 寸法図 Dimensional Drawings

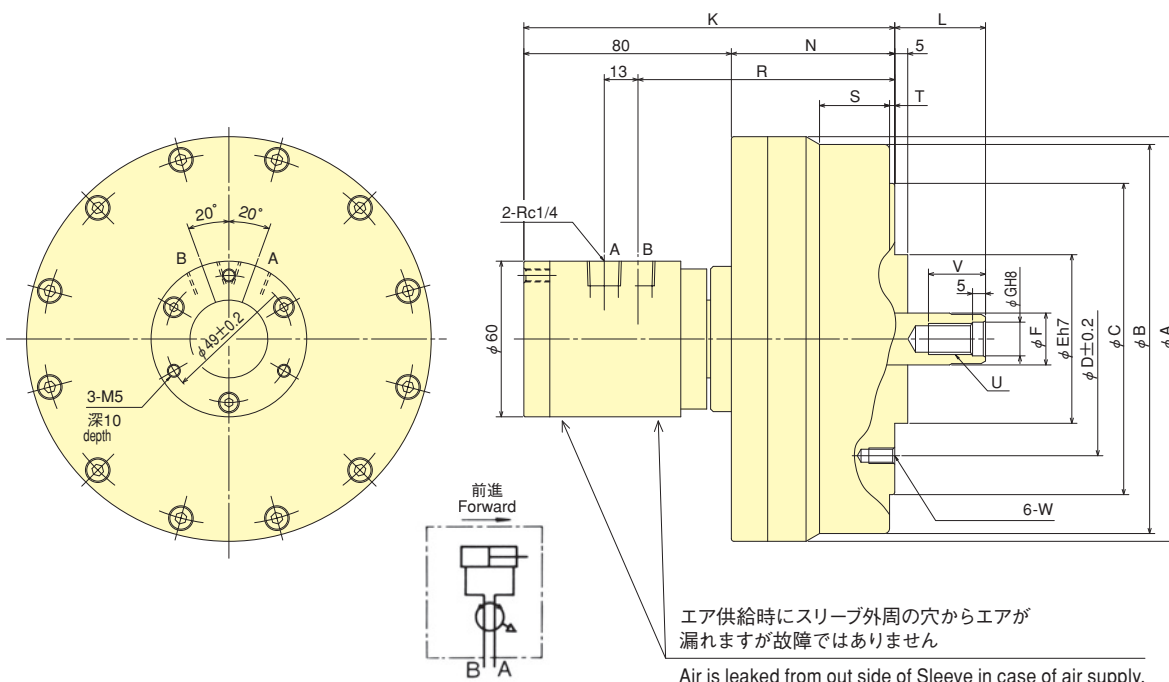

エア供給時にスリーブ外周の穴からエアが漏れますが故障ではありません

Air is leaked from out side of Sleeve in case of air supply, this is not the problem.

■ 寸法表 Dimensions

寸法 Model	A	B	C	D	E (h7)	F	G (H8)	K	L max.	L min.	N	R	S	T	U	V	W 深さ depth
AY1315R	156	150	120	90	65	20	13	143	35	20	63	99	27	2	M12	22	M 6×11
AY1720R	200	195	140	100	80	25	17	162	65	45	82	118	45	5	M16	30	M10×16
AY2225R	255	245	170	130	110	30	21	173	71	46	93	129	33	5	M20	35	M12×20

■ 仕様表 Specifications

※ピストン推力：エア圧0.5MPa【効率75%時】

※Piston thrust : air pressure 0.5MPa[at efficiency 75%]

仕様 Model	ピストンストローク Piston stroke mm	ピストン表面積 Piston Area cm ²	ピストン推力 Piston thrust kN	最高使用エア圧力 Max operation pressure MPa	許容最高回転速度 Max. Speed min ⁻¹	質量 Net Weight kg	慣性モーメント Moment of inertia kg·m ²
AY1315R	15	131	4.9	0.8	5000	5.0	0.010
AY1720R	20	227	8.5	0.8	5000	8.2	0.028
AY2225R	25	378	14.1	0.8	4000	9.8	0.080

回転
Cylinder



CYLINDER

ステーションナリシリンダ Stationary Cylinder YS series

M/C関係にも対応
Suitable for use on Machining Centre
多彩な用途で加工の可能性を拡大
Suitable for a variety of chuck types



- 多種多様なワークに対応できます
Best suited for versatile work-pieces
- ボール盤、フライス盤などに取付けできます
Can be easily mounted to milling and drilling machines
- エアでも油圧でも使用できます
Pneumatic or hydraulic pressure can be supplied

■ 組合せ例 Combination example

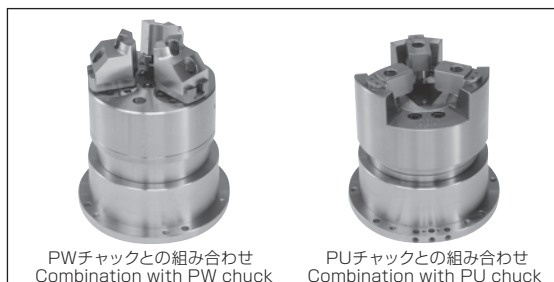

PWチャックとの組み合わせ
Combination with PW chuck

PUチャックとの組み合わせ
Combination with PU chuck

■ 寸法図 Dimensional Drawings

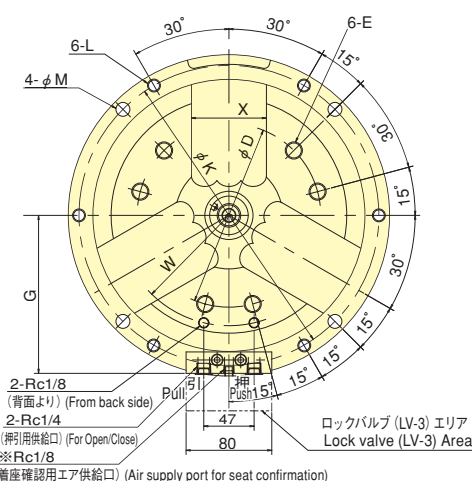
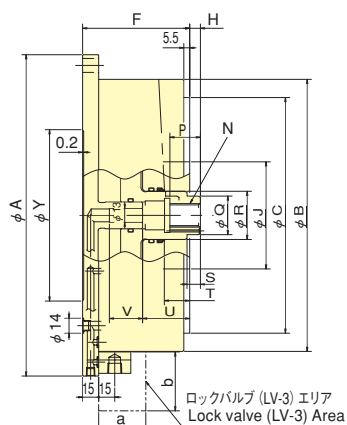

注記 1. 着座確認を行う際は、※印部のオリフィスプラグを外して使用してください。
Note 1. For seat confirmation, please remove Orifice Plug marked with ※.

■ 寸法表 Dimensions *a, bの寸法はLV-3(ロックバルブ)の寸法である。*The dimensions of a/b marked are the size of LV-3(Lock-valve).

型式 Model	φAh7	φB	φCh7	φD	E	F	G	H max.	H min.	φJ	φK (±0.2)	L	φM
YS1415K	203	165	140	104.8	M10 _{深^{depth}17}	72	103	8	-7	75	185	M10	11
YS1820K	248	210	170	133.4	M12 _{深^{depth}24}	92	125.5	11	-9	100	230	M10	11
YS2220K	300	254	220	171.4	M16 _{深^{depth}24}	100	147.5	10	-10	100	280	M12	13

型式 Model	N	P	φQ	φR	S	T	U	V	W	X	Y	a	b
YS1415K	M16	14	-	40	-	9.3	23	25	60	48	95	45	55
YS1820K	M18	21.5	30	40	7.3	17.3	35.5	31	80	70	125	45	55
YS2220K	M22	28.5	36	45	12.5	23.7	44	31	95	70	160	45	55

■ 仕様表 Specifications

型式 Model	ピストン ストローク Piston stroke	最高使用圧力 Max. allowable pressure		最大推力 Max. thrust				質量 Net Weight	適合チャック サイズ Matching chuck size
		エア圧 Pneumatic	油圧 Hydraulic	エア圧 Pneumatic	0.6MPa	油圧 Hydraulic	1.5MPa		
YS1415K	15mm	0.7MPa	1.5MPa	押 Push	8.5kN	押 Push	20.8kN	8kg	6inch
				引 Pull	8.1kN	引 Pull	20.1kN		
YS1820K	20mm	0.7MPa	1.5MPa	押 Push	15.1kN	押 Push	37.7kN	14kg	8inch
				引 Pull	14.6kN	引 Pull	36.5kN		
YS2220K	20mm	0.7MPa	1.5MPa	押 Push	21.4kN	押 Push	53.6kN	21kg	10inch
				引 Pull	20.8kN	引 Pull	51.9kN		



CHUCK

▶ P.85~P.92

ハンドチャック Manual Chuck

ハンドチャック
Manual Chuck



CHUCK

一体爪スクロールチャック (ストレートインロー) Scroll Chuck with Integrated Jaw (Straight Recess) SC・JN series

安心、安定、使い易い
Durable, reliable and versatile
KITAGAWAのスタンダードタイプ
KITAGAWA'S standard type



SC-F Type

- ストレートインロー Straight Recess
- クロスガイド採用 (JNシリーズ) Single Piece Jaw Type

ジョーには、高速回転でもブレや歪みをおさえ、把握力を強化したクロスガイドを採用。また内爪と外爪の2種類を入れ替えて使用でき、その耐久性・経済性の高さは多品種、少量生産に最適。

Available with hard jaw for internal and external gripping.

- スチールボデーを採用 Steel body

スチールボデーの採用によりボデーの剛性アップを図り、耐久性の向上により高速回転での使用が可能。Body is manufactured from high quality steel to increase rigidity, durability and rotational speed.

(SC-3, 4, 5, 14, 16は鋳鉄製) (SC-3, 4, 5, 14, 16 are made of cast iron,
JN-6, 7, 9, 10, 12はスチール製) and JN-6, 7, 9, 10 and 12 are made of steel.)

■ 寸法図 Dimensional Drawings

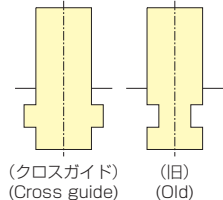
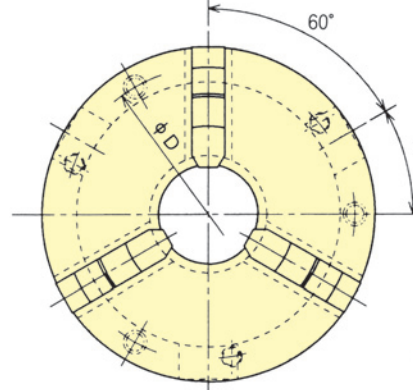
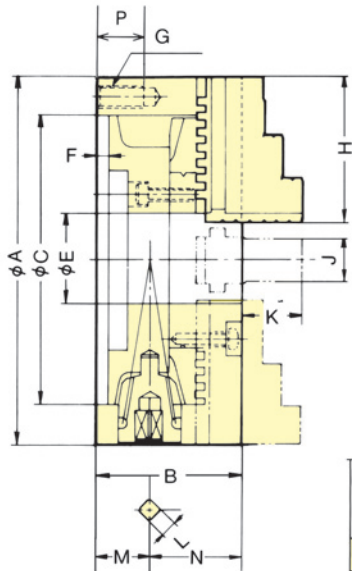

(クロスガイド) (旧)
(Cross guide) (Old)

SC-3~5
JN06~12

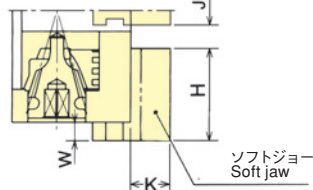

ソフトジョー
Soft jaw

(SC-14, 16の取付60°ピッチ=6本)
(Mounting of SC-14, 16: 60° pitch 6 pcs.)

■ 寸法表 Dimensions

型式 Type	寸法 Size	A	B	C (HG)	D	E	F	G	H	J	K	L	M	N	P	W max.	W min.
SC-3(F)	85	45	60	73	16	3.5	3-M 6	35	11	15	7	17	28	13	(1.5)	(- 7)	
SC-4(F)	110	58	80	95	24	4.5	3-M 8	42	14	18	8	24.5	33.5	16	(2.5)	(-12)	
SC-5(F)	130	60	100	115	32	4.5	3-M 8	50	16	20	8	22.5	37.5	16	(3.5)	(-14.5)	
JN06	165	65	130	147	45	5	3-M10	66	20.5	27	10	24	41	20			
JN07	190	75	155	172	55	5	3-M10	78	22.5	31	11	27.5	47.5	20			
JN09	232	84	190	210	70	6	3-M12	88	26.5	33	12	29.5	54.5	23			
JN10	273	86	230	250	85	6	3-M12	98	26.5	37	12	31.5	54.5	23			
JN12	310	96	260	285	96	7	3-M12	113	30.5	44	14	31.5	64.5	25			
SC-14	355	110	300	328	100	7	6-M12	132	35	52	15	38	72	35			
SC-16	405	120	345	375	110	8	6-M12	146	40	58	15	43.5	76.5	35			

■ 仕様表 Specifications ※把握径/把握範囲は標準のハードジョーを使用した場合。 ※Gripping dia./gripping range is with standard hard jaws.

仕様 Spec.	貫通穴径 Thru-Hole	最大静的把握力 Max. Gripping Force	許容最高回転速度 Max. Speed	質量 Net Weight	慣性モーメント Moment of inertia	把握範囲 Gripping range	ハンドトルク Handle torque	
型式 Type	mm	kN	min ⁻¹	kg	kg·m ²	外径 external φmm	内径 internal φmm	N·m
SC-3(F)	16	9.0	2500	1.5	0.001	2~ 70	24~ 64	29.4
SC-4(F)	24	12.0	2500	3.1	0.004	3~ 95	29~ 84	44.1
SC-5(F)	32	15.0	2500	4.4	0.009	3~110	33~100	63.7
JN06	45	31.0	4000	8.4	0.030	3~160	48~150	88.3
JN07	55	31.0	3500	12.2	0.060	4~180	56~170	107.9
仕様 Spec.	貫通穴径 Thru-Hole	最大静的把握力 Max. Gripping Force	許容最高回転速度 Max. Speed	質量 Net Weight	慣性モーメント Moment of inertia	把握範囲 Gripping range	ハンドトルク Handle torque	
型式 Type	mm	kN	min ⁻¹	kg	kg·m ²	外径 external φmm	内径 internal φmm	N·m
JN09	70	37.0	2900	21.2	0.160	5~220	62~210	147.0
JN10	85	46.0	2500	28.0	0.253	5~260	70~250	176.5
JN12	96	55.0	2200	41.0	0.588	10~300	86~290	206.0
SC-14	100	40.5	1500	54.0	0.950	25~315	107~290	225.6
SC-16	110	45.0	1500	74.0	1.725	25~360	113~340	245.0

※SC型、JN型は内爪、外爪各1セットが標準付属です。JN型はソフトジョーは使えません。SC-F型は内爪、外爪、ソフトジョー各1セットが標準付属です。6インチ以上はこの型はありません。

※SC-F型でソフトジョーを御使用になる場合は、仕様を下げてください。 ※正面取り付けもありますので御相談下さい。

※SC-F型でソフトジョーを使用した場合の把握径/把握範囲はハードジョーを使用した場合と同じです。

※SC type and JN type, each one set of internal jaws and external jaws are attached as standard. Soft jaws cannot be used for JN type. SC-F type, each one set of internal jaws, external jaws and soft jaws are attached as standard.

※When the soft jaws are used for SC-F type, use the chuck of lower specification. ※Since there are types mounted to the front side, please contact your agent if required.

※Gripping dia./gripping range of the SC-F type with soft jaws are the same as with hard jaws.



CHUCK

分割爪スクロールチャック (ストレートインロー) Scroll Chuck with 2 Piece Jaw (Straight Recess) JN-T series

用途に応じてジョーの使い分けが可能 Two piece jaw

- ストレートインロー Straight Recess
- 分割ジョータイプ(ハードジョー、ソフトジョー付)
Cross guide (JN-T series)

トップジョーを重切削に適したハードジョーや、精密仕上げに便利な成形ソフトジョーにと、用途に応じて使い分けが可能。そのうえジョー交換も簡単です。特にハードジョーは、1つのジョーで内径把握・外径把握の両方が可能。

Base jaw is located using cross guide reducing runout and distortion.

- スチールボデーを採用 Steel body

スチールボデーの採用によりボデーの剛性アップを図り、耐久性の向上により高速回転での使用が可能。

Body is manufactured from high quality steel to increase rigidity, durability and rotational speed.

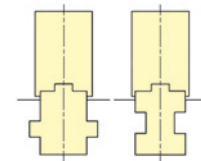

(クロスガイド) (旧)
(Cross guide) (Old)

■寸法図 Dimensional Drawings

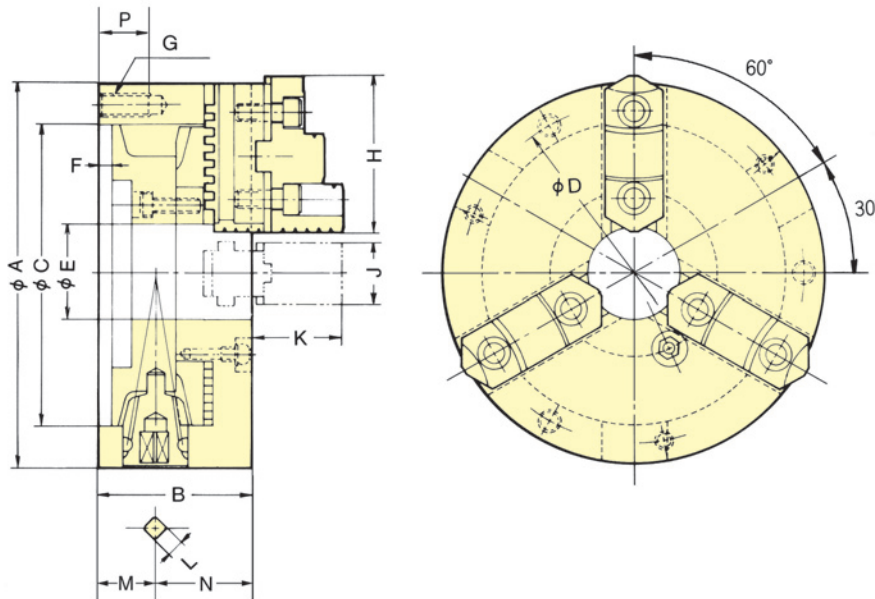

■寸法表 Dimensions

型式 Type	寸法 Size	A	B	C (H6)	D	E	F	G	H	J	K	L	M	N	P
JN06T		165	65	130	147	45	5	3-M10	68	26	39	10	24	41	20
JN07T		190	75	155	172	55	5	3-M10	80	28	42	11	27.5	47.5	20
JN09T		232	84	190	210	70	6	3-M12	90	32	50	12	29.5	54.5	23
JN10T		273	86	230	250	85	6	3-M12	100	35	54	12	31.5	54.5	23
JN12T		310	96	260	285	96	7	3-M12	115	40	56	14	31.5	64.5	25

■仕様表 Specifications ※把握径/把握範囲は標準のハードジョーを使用した場合。*Gripping dia./gripping range is with standard hard jaws.

型式 Type	仕様 Spec.	貫通穴径 Thru-Hole mm	最大静的把握力 Max. Gripping Force kN	許容最高回転速度 Max. Speed min ⁻¹	質量(標準ソフトジョー付) Net Weight with Soft top jaws kg	慣性モーメント Moment of inertia kg·m ²	把握範囲 Gripping range		適合ソフトジョー (ハードジョー) Matching soft jaw (hard jaw)	ハンドトルク Handle torque N·m
							外径 external φ mm	内径 internal φ mm		
JN06T		45	31.0	4000	9.0	0.033	3~160	55~150	SBS06(HBS06C)	88.3
JN07T		55	31.0	3500	13.0	0.063	4~180	62~170	SBS07(HBS07C)	107.9
JN09T		70	37.0	2900	22.0	0.163	5~220	70~210	SBS09(HBS09C)	147.0
JN10T		85	46.0	2500	29.0	0.265	5~260	80~250	SBS10(HBS10C)	176.5
JN12T		96	55.0	2200	43.0	0.588	10~300	90~290	SBS12(HBS12C)	206.0

※ソフトジョー、ハードジョーの寸法はカタログのP117~118参照。正面取り付けもありますので御相談下さい。

※SC-F型でソフトジョーを使用した場合の把握径/把握範囲はハードジョーを使用した場合と同じです。

※For dimensions of soft jaws and hard jaws, refer to pages 117 and 118 on the catalogue. Since there are types mounted to the front side, please contact your agent if required.

※Gripping dia./gripping range with soft jaws are the same as with hard jaws.



CHUCK

前面取付型スクロールチャック (ストレートインロー) Front Mounting Type Scroll Chuck (Straight Recess) **SC・JN・JN-T・JN-TN** series

安心、安定、使い易い

Durable, reliable and versatile

**KITAGAWAのスタンダードタイプ
KITAGAWA'S standard type**

*SC-N, JN-Nは、CE対応品 *SC-N, JN-N : CE corresponding



■ 寸法図 Dimensional Drawings

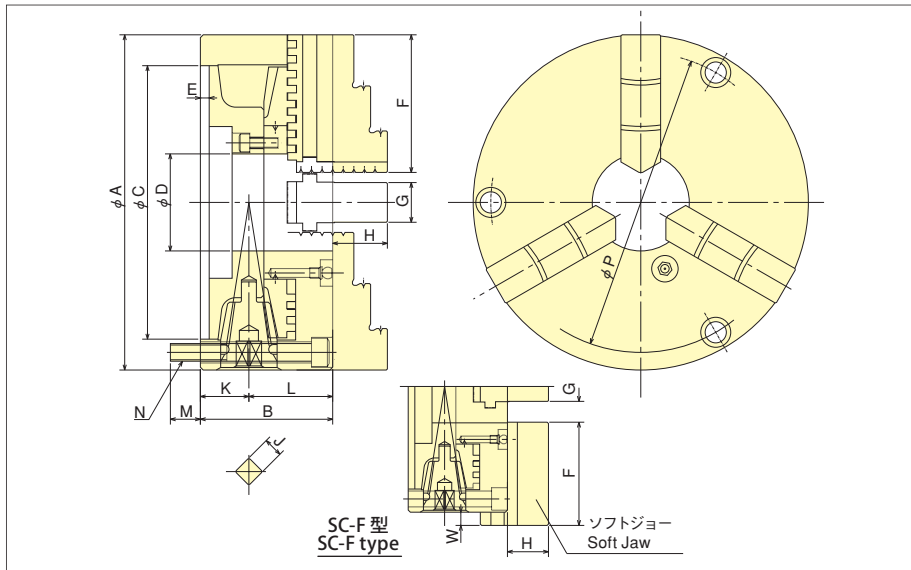

■ 寸法表 Dimensions

①	②	③	A	B	C (H6)	D	E	F	G	H			J	K	L	M	N	P	W (MAX)	W (MIN)
										①	②	③								
SC-3-106	SC-3F113	-	85	45	60	16	3.5	35	11	15	-	-	7	17	28	12	3-M6	71	1.5	-7
SC-4-105	SC-4F-112	SC-4N	110	58	80	24	4.5	42	14	18	18	18	8	24.5	33.5	11	3-M8	93	2.5	-12
SC-5-107	SC-5F-113	-	130	60	100	32	4.5	50	16	20	20	-	8	22.5	37.5	13.6	3-M8	113	3.5	-14.5
JN06-101	JN06T102	JN06TN	165	65	130	45	5	66	20.5	27	39	39	10	24	41	17	3-M10	145	-	-
JN07-101	JN07T102	JN07TN	190	75	155	55	5	78	22.5	31	42	42	11	27.5	47.5	17	3-M10	170	-	-
JN09-101	JN09T102	JN09TN	232	84	190	70	6	88	26.5	33	50	50	12	29.5	54.5	19	3-M12	208	-	-
JN10-101	JN10T102	JN10TN	273	86	230	85	6	98	26.5	37	54	54	12	31.5	54.5	18.5	3-M12	248	-	-
JN12-101	JN12T102	JN12TN	310	96	260	96	7	113	30.5	44	56	56	14	31.5	64.5	18.5	3-M12	282	-	-
SC-14-103	-	-	355	110	300	100	7	132	35	52	-	-	15	38	72	27	6-M14	328	-	-
SC-16-113	-	-	405	120	345	110	8	146	40	58	-	-	15	43.5	76.5	27	6-M14	375	-	-

■ 仕様表 Specifications *把握径/把握範囲は標準のハードジョーを使用した場合。*Gripping dia./gripping range is with standard hard jaws.

①	②	③	最大静的把握力(kN) Max.Gripping Force	質量(標準ソフトジョー付)(kg) Net Weight with Soft top jaw	慣性モーメント(kg・m ²) Moment of inertia	把握範囲 Gripping range		ハンドトルク(N・m) Handle torque
						把握範囲 外径 Outer diaφ (mm)	把握範囲 内径 Inner diaφ (mm)	
SC-3-106	SC-3F113	-	9	1.5	0.001	2~70	24~64	29.4
SC-4-105	SC-4F-112	SC-4N	12	3.1	0.004	3~95	29~84	44.1
SC-5-107	SC-5F-113	-	15	4.4	0.009	3~110	33~100	63.7
JN06-101	-	-	31	8.4	0.030	3~160	48~150	88.3
-	JN06T102	JN06TN				3~160	55~150	
JN07-101	-	-	31	12.2	0.060	4~180	56~170	107.9
-	JN07T102	JN07TN				4~180	62~170	
JN09-101	-	-	37	21.2	0.160	5~220	62~210	147.0
-	JN09T102	JN09TN				5~220	70~210	
JN10-101	-	-	46	28	0.253	5~260	70~250	176.5
-	JN10T102	JN10TN				5~260	80~250	
JN12-101	-	-	55	41	0.588	10~300	86~290	206.0
-	JN12T102	JN12TN				10~300	90~290	
SC-14-103	-	-	40.5	54	0.950	25~315	107~290	225.6
SC-16-113	-	-	45	74	1.725	25~360	113~340	245.0

注) 1. ①のSC型、JN型は、硬爪の内爪と外爪各1セットが標準付属です。JN型、SC-14、SC-16にはソフトジョーは使えません。 Note) 1. ①SC type and JN type, each one set of mono internal jaws and mono external jaws are attached as standard with. Soft jaws cannot be used with JN type, SC-14, and SC-16.
2. ②のSC-F型は、一体型硬爪の内爪と外爪および一体型ソフトジョー各1セットが標準付属です。
2. ②SC-F type, each one set of internal jaws, external jaws and soft jaws are attached as standard.
3. SC-F型でソフトジョーを併用する場合は、仕様を下げてお使い下さい。
3. When the soft jaws are used for SC-F type, use the chuck of lower specification.
4. JN-T(N)は分割型内外兼用硬爪および分割型ソフトジョー各1セットが標準付属です。
4. JN-T(N) type, each one set of two piece hard jaws and two piece soft jaws are attached as standard.
5. ③のSC-N、JN-Nは、CE対応品となりハンドルのみ違います。
5. ③SC-N type and JN-N type are chucks applying to CE certificate.
6. 取り付けるNC円テーブルにより、把握範囲に制限を受けることがあります。
6. Gripping range is limited depending on the NC rotary table to mount.
7. JN-TとJN-TNでソフトジョーを使用した場合の把握径/把握範囲は、ハードジョーを使用した場合と同じです。
7. Gripping dia./gripping range of the JN-T type and JN-TN type with soft jaws are the same as with hard jaws.



CHUCK

分割爪スクロールチャック (ショートテーパ) Scroll Chuck with 2 Piece Jaw (Direct Mount) JN-RA series

用途に応じてジョーの使い分けが可能 Two piece jaw

●ショートテーパ Short taper

アダプタなしで直接取り付けできるショートテーパ用チャック。本体は軽量で継ぎ目のない高剛性ソリッドボデー。

Direct mount to short taper without the need for separate adaptor.

ご注文の際はお近くの販売店または弊社にお客様ご使用の旋盤メーカー名・型式をご連絡ください。(P.131参照)

When placing an order, establish contact with your agent or our company to advise a manufacturer name and type of a lathe used in a customer shop. (refer to P.132)

●ソフトジョー(オプション) Soft jaw (option)

ハードジョーが標準付属。ソフトジョーも使用可能。(オプション、JN-Tタイプと兼用)

Supplied with standard hard jaws (fitted). Soft jaw can also be used. (Option, used together with JN-T type)



■寸法図 Dimensional Drawings

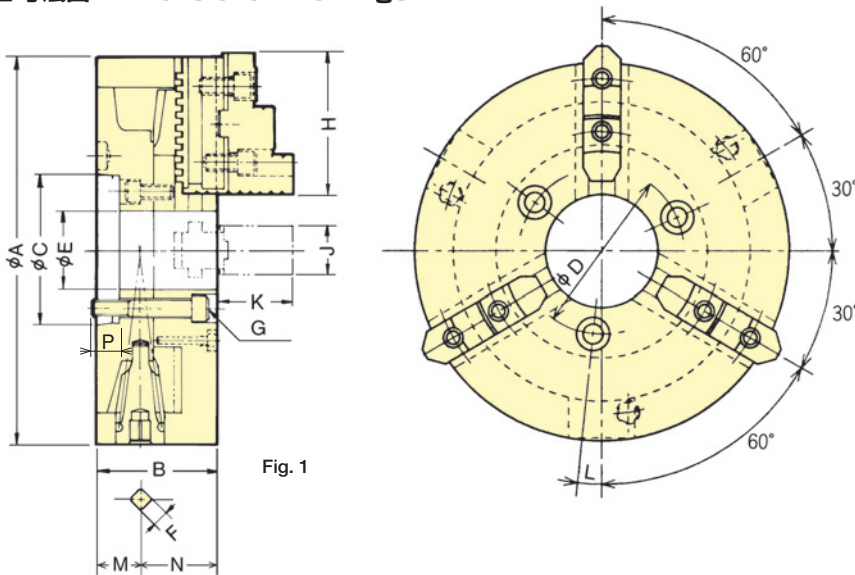
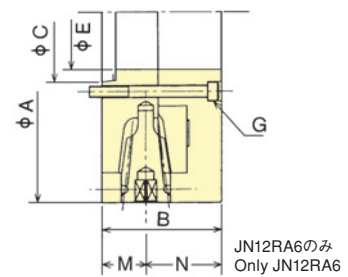

Fig. 2



■寸法表 Dimensions

型式 Type	寸法 Size	A	B	C	D	E	F	G	H	J	K	L	M	N	P
JN06RA5		165	65.5	82.563	61.9	40	10	3-M10	68	26	39	6°	24	41	16
JN07RA5		190	75	82.563	61.9	40	11	3-M10	80	28	42	5°	27.5	47.5	16.5
JN08RA6		210	75	106.375	82.6	59	11	3-M12	80	28	42	6°	29	46	15.5
JN09RA6		232	84	106.375	82.6	59	12	3-M12	90	32	50	6°	29.5	54.5	16.5
JN10RA6		273	86	106.375	82.6	59	12	3-M12	100	35	54	0°	31.5	54.5	14.5
JN10RA8		273	86	139.719	111.1	78	12	3-M16	100	35	54	15°	31.5	54.5	18.5
JN12RA6		310	96	106.375	133.4	96	14	3-M12	115	40	56	0°	31.5	64.5	18.5
JN12RA8		310	96	139.719	111.1	78	14	3-M16	115	40	56	0°	31.5	64.5	23.5

■仕様表 Specifications ※把握径/把握範囲は標準のハードジョーを使用した場合。*Gripping dia./gripping range is with standard hard jaws.

型式 Type	仕様 Spec. Thru-Hole mm	最大静的把握力 Max. Gripping Force kN	許容最高回転速度 Max. Speed min ⁻¹	質量 Net Weight kg	慣性モーメント Moment of inertia kg·m ²	把握範囲 Gripping range		適合ハードジョー Matching Hard top jaw	ハンドトルク Handle torque N·m
						外径 external φ mm	内径 internal φ mm		
JN06RA5	40	31.0	4000	9.3	0.035	3~160	55~150	HBS06C	88.3
JN07RA5	40	31.0	3500	13.4	0.068	4~180	62~170	HBS07C	107.9
JN08RA6	59	31.0	3200	18.0	0.103	4~200	62~190	HBS07C	107.9
JN09RA6	59	37.0	2900	23.5	0.170	5~220	70~210	HBS09C	147.0
JN10RA6	59	46.0	2500	30.5	0.275	5~260	80~250	HBS10C	176.5
JN10RA8	78	46.0	2500	31.0	0.280	5~260	80~250	HBS10C	176.5
JN12RA6	96	55.0	2200	44.0	0.595	10~300	90~290	HBS12C	206.0
JN12RA8	78	55.0	2200	45.0	0.608	10~300	90~290	HBS12C	206.0



CHUCK

2爪スクロールチャック (ストレートインロー) 2-Jaw Scroll Chuck (Straight Recess) JT series

バルブ、管継手など異形物の把握に最適
This two jaw chuck provides the optimum solution for gripping valves, pipe joints and other irregularly shaped components

● **ストレートインロー Straight recess**

取付部の寸法は、JNタイプと同様。
Mounting dimensions are the same as the JN type.



■ **寸法図 Dimensional Drawings**

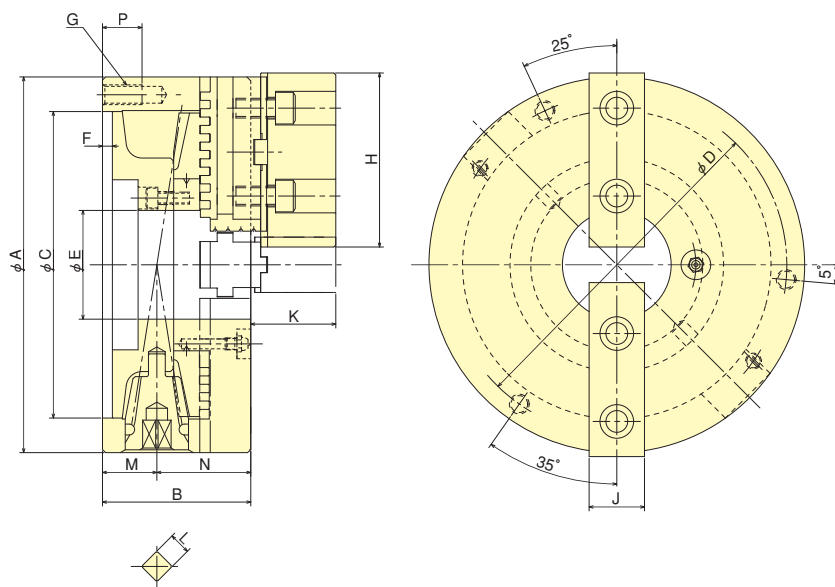

■ **寸法表 Dimensions**

型式 Type	寸法 Size	A	B	C 寸法 Size	C 公差 Tolerance	D 寸法 Size	D 公差 Tolerance	E	F	G	H	J	K	L 寸法 Size	L 公差 Tolerance	M	N	P
JT07		190	75	155	+0.025 0	172	±0.2	55	5	3-M10	88	28	43	11	+0.15 +0.05	27.5	47.5	20
JT09		232	84	190	+0.029 0	210	±0.2	70	6	3-M12	100	32	50	12	+0.15 +0.05	29.5	54.5	23

■ **仕様表 Specifications**

*把握径/把握範囲は標準のソフトジョーを使用した場合。*Gripping dia./gripping range is with standard soft jaws.

型式 Type	仕様 Spec.	貫通穴径 Thru-Hole mm	最大静的把握力 Max. Gripping Force kN	許容最高回転速度 Max. Speed min ⁻¹	質量 (標準ソフトジョー付) Net Weight with Soft top jaws kg	慣性モーメント Moment of inertia kg·m ²	把握範囲 Gripping range		適合ソフトジョー Matching Soft top jaw	ハンドトルク Handle torque N·m
							外径 external φ mm	内径 internal φ mm		
JT07		55	20.7	3500	12.6	0.065	4~180	62~170	JT07用 For JT07	73.5
JT09		70	24.7	2900	21.4	0.160	5~220	70~210	JT09用 For JT09	98.0



CHUCK

4爪スクロールチャック (ストレートインロー) 4-Jaw Scroll Chuck (Straight Recess) JS series

異形ワークも安定把握

Reliable and effective gripping of irregularly shaped components



●異形ワークも把握可能

Thin walled materials ensure minimal distortion, even with thin-walled cylindrical pipe

特にパイプ等肉厚の少ないものをつかむ場合の歪みを小さくします。角もの(正方形)も把握可能。

●ストレートインロー Straight recess

取付部の寸法は、JNタイプと同様。

Mounting dimensions are the same as the JN type.

■寸法図 Dimensional Drawings

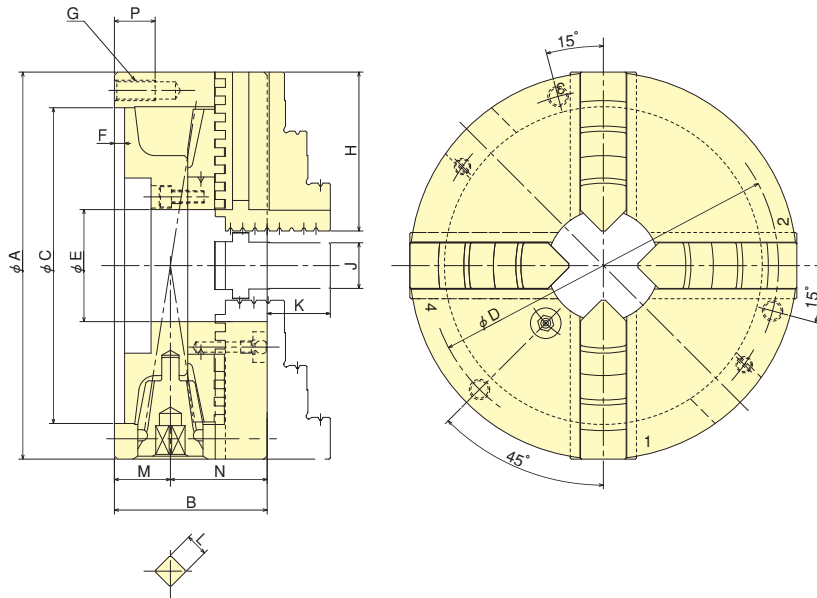

■寸法表 Dimensions

型式 Type	寸法 Size		C 寸法 Size	C 公差 Tolerance	D 寸法 Size	D 公差 Tolerance	E	F	G	H	J	K	L 寸法 Size	L 公差 Tolerance	M	N	P
	A	B															
JS07	190	75	155	+0.025 0	172	±0.2	55	5	3-M10	78	22.4	31	11	+0.15 +0.05	27.5	47.5	20
JS09	232	84	190	+0.029 0	210	±0.2	70	6	3-M12	88	26.4	33	12	+0.15 +0.05	29.5	54.5	23

■仕様表 Specifications

※把握径/把握範囲は標準のハードジョーを使用した場合。※Gripping dia./gripping range is with standard hard jaws.

型式 Type	仕様 Spec.	貫通孔径 Thru-Hole mm	最大静的把握力 Max. Gripping Force kN	許容最高回転速度 Max. Speed min ⁻¹	質量 Net Weight kg	慣性モーメント Moment of inertia kg·m ²	把握範囲 Gripping range		ハンドルトルク Handle torque N·m
							外径 external φ mm	内径 internal φ mm	
JS07		55	31.0	3500	12.5	0.063	4~180	56~170	107.9
JS09		70	37.0	2900	21.5	0.163	5~220	62~210	147.0



CHUCK

インディペンデントチャック (ストレートインロー) Independent Chuck (Straight Recess) IC series

4爪単動のKITAGAWAスタンダードタイプ Independent 4 Jaw Chuck

- ストレートインロー
Straight recess



■ 寸法図 Dimensional Drawings

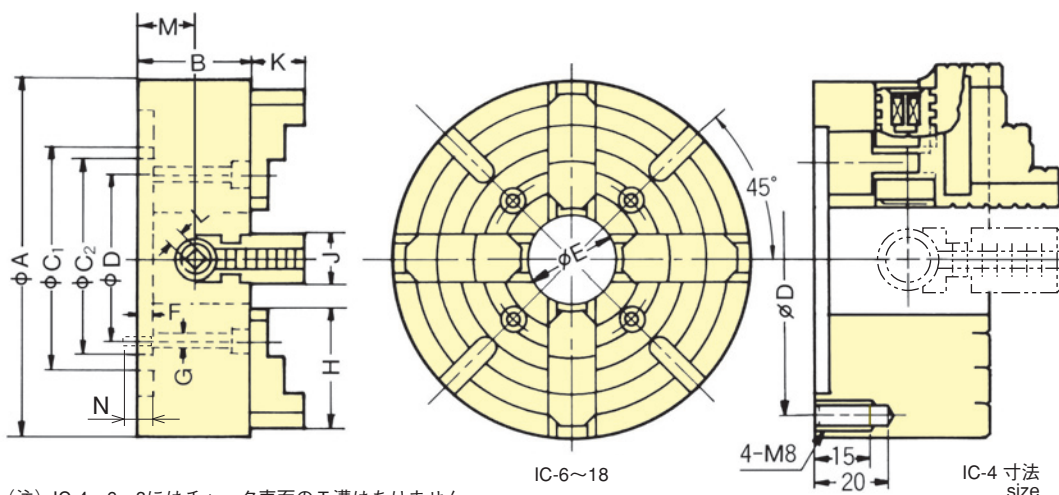

(注) IC-4、6、8にはチャック表面のT溝はありません。
(Note) In IC-4, 6 and 8, there is no T-groove on the chuck surface.

■ 寸法表 Dimensions

型式 Type	寸法 Size		C ₁	C ₂		D	E	F	G	H	J	K	L		M	N
	A	B		寸法 Size	公差 Tolerance								寸法 Size	公差 Tolerance		
IC-4	100	48	-	75H7	+0.030	86	30	4	-	40	18	20	6	-	26	-
IC-6	150	60	-	130H7	+0.040	115	40	5	4-M10	55	25	25	8	-	33	16
IC-8	200	75	-	175H7	0	155	50	6	4-M12	75	30	30	10	+0.15	43.5	20
IC-10	250	80	165	150H7	0	125	55	6	4-M12	90	30	35	10	+0.05	47.5	21
IC-12	300	90	186	170H7	+0.046	140	65	6	4-M12	100	35	40	12	-	53	21
IC-14	350	90	210	190H7	0	160	75	8	4-M12	110	35	45	12	-	53	18
IC-16	400	100	230	210H7	0	180	90	8	4-M16	120	40	50	14	-	58.5	24
IC-18	450	105	250	230H7	0	200	100	8	4-M16	130	40	55	14	-	63.5	24

■ 仕様表 Specifications

仕様 Spec. 型式 Type	貫通穴径 Thru-Hole mm	最大静的把握力 Max. Gripping Force		最大把握径 Max. Gripping dia.		最小把握径 Min. Gripping dia.		チャック Chuck		
		ハンドルトルク Handle torque N·m	ジョー1個締付力 Tightening force of a jaw kN	内爪 Inner jaw φmm	外爪 Outer jaw φmm	内爪 Inner jaw φmm	内爪 Inner jaw φmm	質量 Net Weight kg	慣性モーメント Moment of inertia kg·m ²	許容最高回転速度 Max. Speed min ⁻¹
IC-4	30	34.0	5.0	40	90	8	8	2.4	0.003	2000
IC-6	40	49.0	6.0	60	140	8	8	6.1	0.020	1600
IC-8	50	83.0	10.0	75	185	14	14	14.8	0.075	1600
IC-10	55	118.0	14.0	95	220	14	14	21.0	0.150	1600
IC-12	65	147.0	16.0	125	265	18	18	29.5	0.350	1400
IC-14	75	157.0	17.0	155	310	20	20	40.0	0.725	1400
IC-16	90	216.0	20.0	190	360	30	30	56.5	1.125	1200
IC-18	100	216.0	20.0	220	405	35	35	70.0	1.750	1200

※治具取付用T溝はIC-10以上のチャックについております。
 ※取付ボルトは4本付属しております。(IC-4を除きすべて本体面より六角穴付ボルトにて取付けます。したがってバックプレートにねじ穴を設けて下さい。)
 ※六角棒スパナは各サイズ(IC-4を除く)1本付属しています。
 ※T-slot for jig mounting is provided from IC-10 or more.
 ※Four mounting bolts are provided. (Except IC-4, chucks are mounted with hexagon socket set screws. Thus tapped holes is required on Backplate.)
 ※One hex wrench is attached for the chuck of each size (except IC-4).



CHUCK

インディペンデントチャック (ショートテーパ) Independent Chuck (Short Taper) IA series

4爪単動のKITAGAWAスタンダードタイプ Independent 4 Jaw Chuck

- バックプレートなしで、直接取り付けできるショートテーパ用チャックです
Chuck for short taper that can be directly mounted without back plate



■ 寸法図 Dimensional Drawings

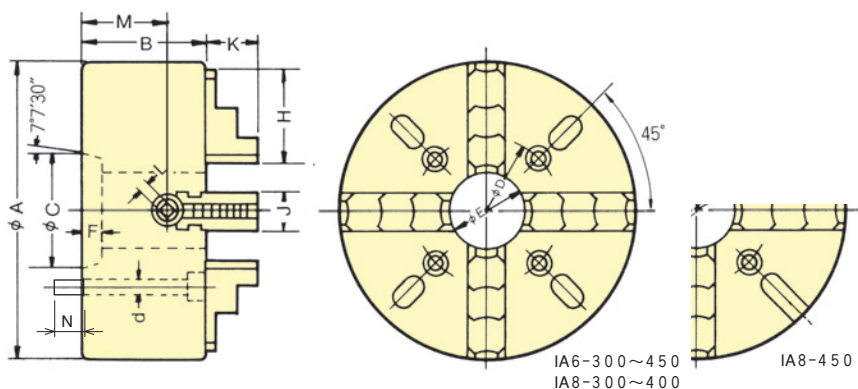

(注) IA5-200とIA6-250にはチャック表面のT溝はありません。
(Note) No T slot on the chuck surface for IA5-200 and IA6-250.

■ 寸法表 Dimensions

主軸端呼び Spindle Nose	型式 Type	寸法 Size	A	B	C	D	E	F	H	J	K	L	M	N	(取付ボルト) (Mounting bolt)	dの本数 Number of mounting bolts
A2- 5	IA 5 -200	200	70	82.563	104.8	50	15	75	30	30	10	38.5	17	M10×75	4	
	IA 6 -250	250	77	106.375	133.4	55	17	90	30	35	10	44.5	17	M12×80	4	
A2- 6	IA 6 -300	300	90	106.375	133.4	65	17	100	35	40	12	53	19	M12×95	4	
	IA 6 -350	350	90	106.375	133.4	75	17	110	35	45	12	53	19	M12×95	4	
	IA 6 -400	400	100	106.375	133.4	75	17	120	40	50	14	58.5	17	M12×100	4	
	IA 6 -450	450	105	106.375	133.4	80	17	130	40	55	14	63.5	20	M12×110	8	
A2- 8	IA 8 -300	300	100	139.719	171.4	75	18.5	120	40	50	14	58.5	24	M16×105	4	
	IA 8 -350	350	100	139.719	171.4	75	18.5	120	40	50	14	58.5	24	M16×105	4	
	IA 8 -400	400	105	139.719	171.4	90	18.5	120	40	50	14	58.5	24	M16×110	4	
	IA 8 -450	450	105	139.719	171.4	100	18.5	130	40	55	14	63.5	24	M16×110	4	

■ 仕様表 Specifications ※IA-6-450の取付 45°ピッチ8本 ※Mounting of IA-6-450 : 45° pitch, 8 pcs.

主軸端呼び Spindle Nose	型式 Type	仕様 Spec. 貫通穴径 Thru-Hole mm	最大静的把握力 Max. Gripping Force		最大把握径 Max. Gripping dia.		最小把握径 Min. Gripping dia.		チャック Chuck		
			ハンドルトルク Handle torque N·m	ジョー1個締付力 Tightening force of a jaw kN	内爪 Inner jaw φmm	外爪 Outer jaw φmm	内爪 Inner jaw φmm	内爪 Inner jaw φmm	質量 Net Weight kg	慣性モーメント Moment of inertia kg·m ²	許容最高回転速度 Max. Speed min ⁻¹
A2- 5	IA 5 -200	50	83.0	10.0	75	185	14	14.9	0.080	3600	
	IA 6 -250	55	118.0	15.0	95	220	14	24.2	0.188	3000	
A2- 6	IA 6 -300	65	147.0	16.0	125	265	18	39.1	0.400	2000	
	IA 6 -350	75	147.0	16.0	155	310	20	50.9	0.750	2000	
	IA 6 -400	75	216.0	20.0	190	360	30	69.8	1.175	1800	
	IA 6 -450	80	245.0	23.0	220	405	35	97.2	1.775	1200	
A2- 8	IA 8 -300	75	147.0	16.0	90	265	18	39.1	0.400	2000	
	IA 8 -350	75	216.0	20.0	135	310	20	56.2	0.775	2000	
	IA 8 -400	90	245.0	23.0	190	360	30	73.8	1.250	1800	
	IA 8 -450	100	245.0	23.0	220	405	35	102.5	1.825	1200	



**WORK
GRIPPER**

▶ **P.95~P.109**

ワークグリッパ Work Gripper

**WORK GRIPPER****ワークグリッパ****AS series**

ステーションリチャックのKITAGAWAスタンダードタイプ M/C関係のワークホールディングもKITAGAWA

- エアシリンダを内蔵した薄型・軽量設計
- エア配管だけで取付け簡単
- パワーワークやエアブローに最適の中空構造
- 当社パワーチャックとのソフトジョー共用可能
- オプションのロックバルブユニット使用により、配管を外して加工可能

※配管回路にルブリケータを設けてください。

*CE対応品



■ 寸法図

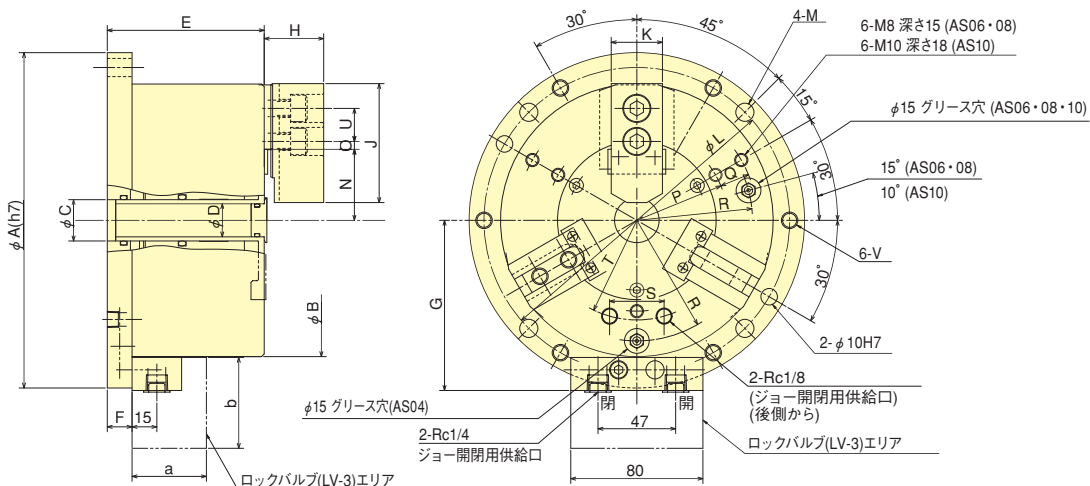

■ 寸法表 ※a, bの寸法はLV-3(ロックバルブ)の寸法

型式	寸法	$\phi A(h7)$	ϕB	$\phi C(h7)$	ϕD	E	F	G	H	J	K	$\phi L(\pm 0.2)$	ϕM	N max.	N min.	O max.	O min.	P	Q	R
AS04		148	110	20	-	90	15	75.5	27	55	23	130	9	25.5	22.9	9.75	6.75	-	-	43
AS06		203	165	25	20	95	15	103	36	72	31	185	11	44.5	41.9	9.25	4.75	55	18	70
AS08		248	210	36	30	106	15	125.5	42	95	35	230	11	53	49.85	14.75	8.75	68	25	90
AS10		300	254	50	43	110	16	147.5	46	110	40	280	13	66	62.85	16	8.5	85	30	110

型式	寸法	S	T	U	V	a	b
AS04		33	34	14	M8	45	55
AS06		33	60.3	20	M10	45	55
AS08		33	80	25	M10	45	55
AS10		33	95	30	M12	45	55

※空気消費量はプランジャストローク10mm当り、圧力0.7MPa時

※把握径/把握範囲は標準のソフトジョーを使用した場合。

■ 仕様表

型式	仕様	ジョーストローク (直径) mm	把握力 [エア圧力 0.7MPa] kN	質量 kg	許容最大エア圧力 MPa	適用ソフトジョー	把握径 mm		空気消費量 (N _d)
							Max.	Min.	
AS04		5.2	8.8	7.3	0.7	SJ04B1	110	8	0.47
AS06		5.2	24.5	16.0	0.7	SJ06B1	165	26	1.21
AS08		6.3	38.5	27.7	0.7	SJ08B1	210	38	2.11
AS10		6.3	56	42.5	0.7	SJ10A1	254	53	2.94



WORK GRIPPER

Work Gripper AS series

Pneumatically operated stationary chuck Can be used as an alternative to a fixture

- Small and lightweight design, with inbuilt air cylinder
- Easy mounting by air piping
- Hollow structure optimal for bar work-piece and air blow
- Standard Soft Jaw for Power Chuck is used
- By using the optional lock valve unit, it is possible to remove the piping during machining



※Provide a lubricator in the piping circuit.

*CE corresponding

Dimensional Drawings

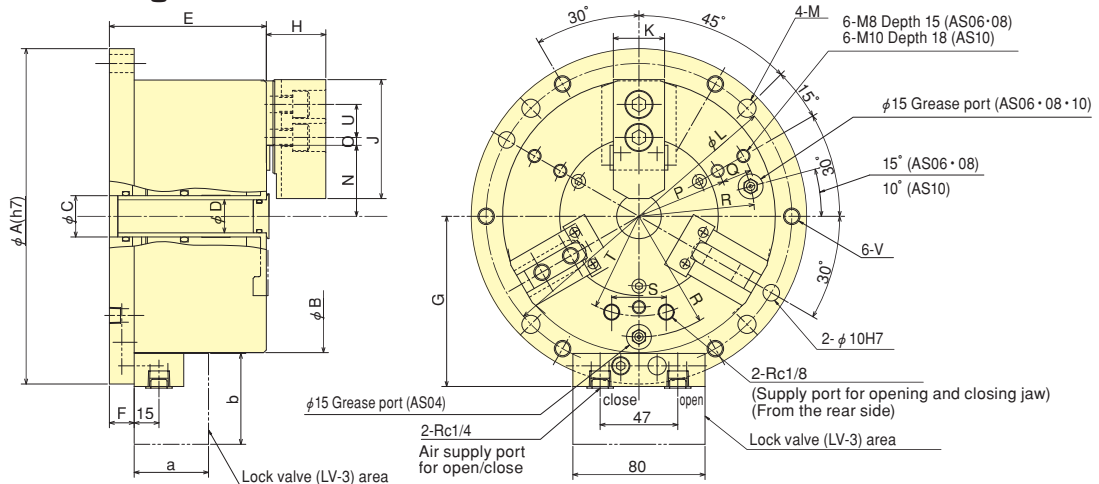

Dimensions

※The dimensions of a/b marked are the size of LV-3(Lock-valve).

Model	Dimensions	ϕA (h7)	ϕB	ϕC (H7)	ϕD	E	F	G	H	J	K	ϕL (± 0.2)	ϕM	N max.	N min.	O max.	O min.	P	Q	R
AS04		148	110	20	—	90	15	75.5	27	55	23	130	9	25.5	22.9	9.75	6.75	—	—	43
AS06		203	165	25	20	95	15	103	36	72	31	185	11	44.5	41.9	9.25	4.75	55	18	70
AS08		248	210	36	30	106	15	125.5	42	95	35	230	11	53	49.85	14.75	8.75	68	25	90
AS10		300	254	50	43	110	16	147.5	46	110	40	280	13	66	62.85	16	8.5	85	30	110

Model	Dimensions	S	T	U	V	a	b
AS04		33	34	14	M8	45	55
AS06		33	60.3	20	M10	45	55
AS08		33	80	25	M10	45	55
AS10		33	95	30	M12	45	55

※Air Consumption = Under Pressure 0.7MPa Plunger Stroke per 10mm

※Gripping dia./gripping range is with standard soft jaws.

Specifications

Model	Specifications	Jaw Stroke (diameter) mm	Gripping Force [Pneumatic at 0.7MPa] kN	Net Weight kg	Max. air pressure MPa	Matching Soft top jaw	Gripping range mm		Air consumption (N _l)
							Max.	Min.	
AS04		5.2	8.8	7.3	0.7	SJ04B1	110	8	0.47
AS06		5.2	24.5	16.0	0.7	SJ06B1	165	26	1.21
AS08		6.3	38.5	27.7	0.7	SJ08B1	210	38	2.11
AS10		6.3	56	42.5	0.7	SJ10A1	254	53	2.94

ワークグリップ
Work Gripper



WORK GRIPPER

2爪ワークグリッパ

AT series

突起物ワークも確実把握

M/C関係のワークホールディングもKITAGAWA

- エアシリンダを内蔵した薄型・軽量設計
- エア配管だけで取付け簡単
- バーワークやエアブローに最適の中空構造
- 当社パワーチャックとのソフトジョー共用可能
- オプションのロックバルブユニット使用により、配管を外して加工可能



※配管回路にルブリケータを設けてください。

*CE対応品

■ 寸法図

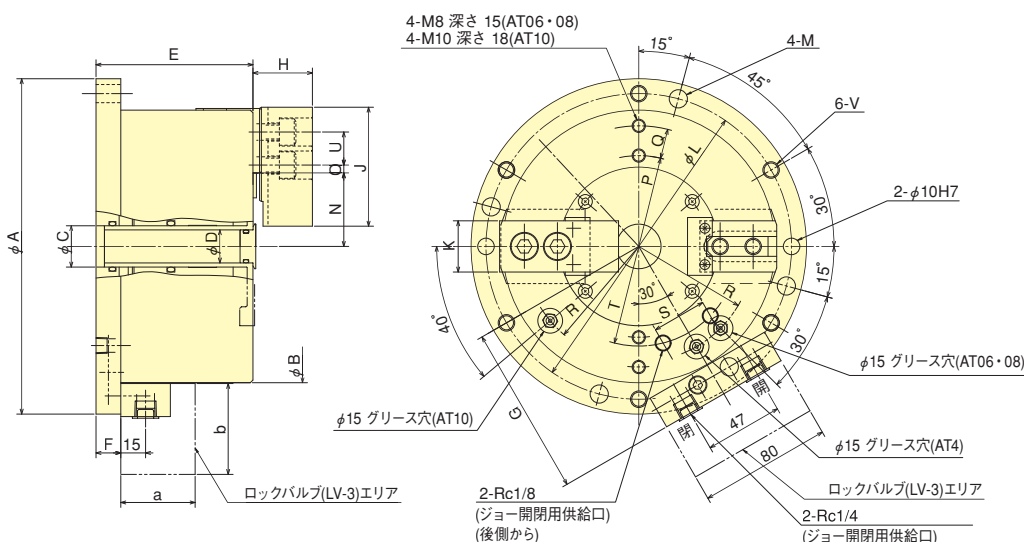

■ 寸法表 ※a, bの寸法はLV-3(ロックバルブ)の寸法

型式	寸法	φA (H7)	φB	φC	φD	E	F	G	G	H	J	K	φL (±0.2)	φM	N max.	N min.	O max.	O min.	P	Q
AT04		148	110	20H7	-	90	15	75.5	(110.5)	27	55	23	130	9	25.5	22.9	8.75	7.25	-	-
AT06		203	165	25H7	20	95	15	103	(138)	36	72	31	185	11	44.5	41.9	9.25	4.75	55	18
AT08		248	210	36H7	30	106	15	125.5	(160.5)	42	95	35	230	11	53	49.85	15	9	68	25
AT10		300	254	50H7	43	110	16	147.5	(182.5)	46	110	40	280	13	66	62.85	16	8.5	85	30

型式	寸法	R	S	T	U	V	a	b
AT04		43	33	34	14	M8	45	55
AT06		70	33	60.3	20	M10	45	55
AT08		90	33	80	25	M10	45	55
AT10		110	33	95	30	M12	45	55

■ 仕様表 ※空気消費量はプランジャストローク10mm当り、圧力0.6MPa時 ※把握径/把握範囲は標準のソフトジョーを使用した場合。

型式	仕様	ジョーストローク (直径) mm	把握力 [エア圧力 0.6MPa] kN	質量 kg	許容最大エア圧力 MPa	適用ソフトジョー	把握径 mm		空気消費量 (N _l)
							Max.	Min.	
AT04		5.2	7.5	6.9	0.6	SJ04A1T	110	10	0.40
AT06		5.2	21.0	15.0	0.6	SJ06A1T	165	31	1.04
AT08		6.3	33.0	26.7	0.6	SJ08A1	210	41	1.81
AT10		6.3	48.0	40.8	0.6	SJ10A1	254	61	2.52



WORK GRIPPER

2-Jaw Work Gripper

AT series

Secure gripping of all types of component
Can be used as an alternative to a fixture

- Small and lightweight design, with inbuilt air cylinder
- Easy mounting by air piping
- Hollow structure optimal for bar work-piece and air blow
- Standard Soft Jaw for Power Chuck is used
- By using the optional lock valve unit, it is possible to remove the piping during machining

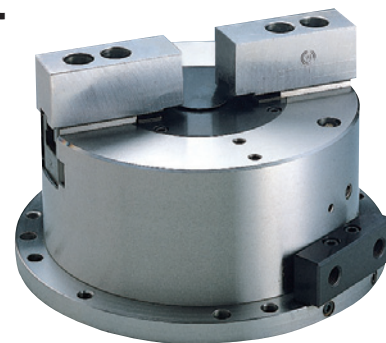

※Provide a lubricator in the piping circuit.

*CE corresponding

Dimensional Drawings

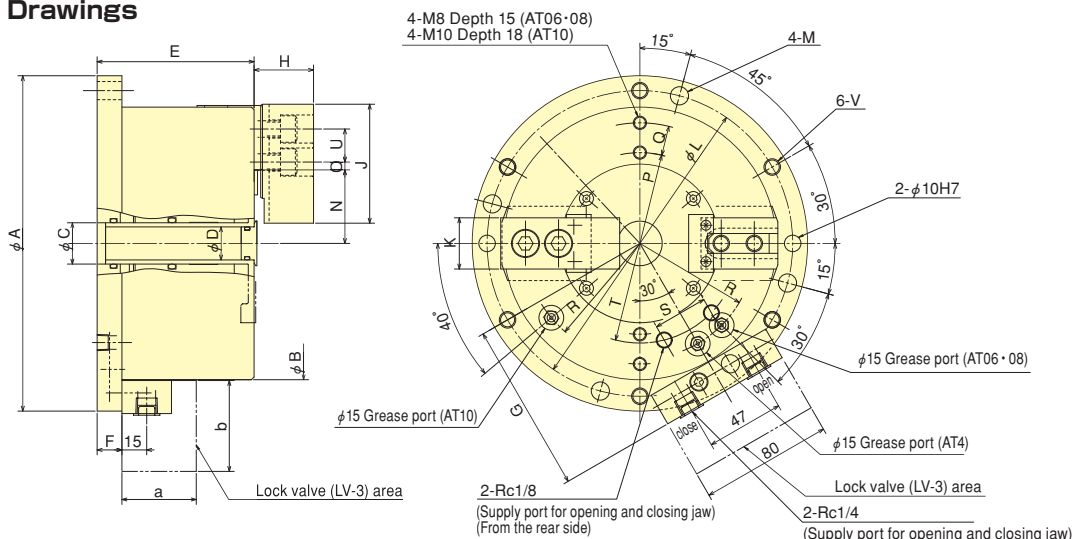

Dimensions

※The dimensions of a/b marked are the size of LV-3(Lock-valve).

Model	Dimensions	φA (H7)	φB	φC	φD	E	F	G	G	H	J	K	φL (±0.2)	φM	N max.	N min.	O max.	O min.	P	Q
AT04		148	110	20H7	—	90	15	75.5	(110.5)	27	55	23	130	9	25.5	22.9	8.75	7.25	—	—
AT06		203	165	25H7	20	95	15	103	(138)	36	72	31	185	11	44.5	41.9	9.25	4.75	55	18
AT08		248	210	36H7	30	106	15	125.5	(160.5)	42	95	35	230	11	53	49.85	15	9	68	25
AT10		300	254	50H7	43	110	16	147.5	(182.5)	46	110	40	280	13	66	62.85	16	8.5	85	30

Model	Dimensions	R	S	T	U	V	a	b
AT04		43	33	34	14	M8	45	55
AT06		70	33	60.3	20	M10	45	55
AT08		90	33	80	25	M10	45	55
AT10		110	33	95	30	M12	45	55

Specifications

※Air Consumption = Under Pressure 0.6MPa Plunger Stroke per 10mm
 ※Gripping dia./gripping range is with standard soft jaws.

Model	Specifications	Jaw Stroke (diameter) mm	Gripping Force [Pneumatic at 0.6MPa] kN	Net Weight kg	Max. air pressure MPa	Matching Soft top jaw	Gripping range mm		Air consumption (N _l)
							Max.	Min.	
AT04		5.2	7.5	6.9	0.6	SJ04A1T	110	10	0.40
AT06		5.2	21.0	15.0	0.6	SJ06A1T	165	31	1.04
AT08		6.3	33.0	26.7	0.6	SJ08A1	210	41	1.81
AT10		6.3	48.0	40.8	0.6	SJ10A1	254	61	2.52



WORK GRIPPER

パワーウイングワークグリッパ PWS06

旋盤用チャックがM/C用に変身 シリンダ内蔵でコストダウン

- ワーク素材を引き込む安定把握
旋盤工程前後の荒加工用に使用すれば、同じ把握状態で省段取り
- シリンダ内蔵で導入コストダウン *別途チャック作用用シリンダが不要です
- 機械標準コラム仕様で対応可能 *シリンダ内蔵で全高を低く抑えました
- NC円テーブルにスムーズ搭載
- オプションのロックバルブユニット使用により、配管を外して加工可能

※配管回路にルブリケータを設けてください。

*CE対応品



■ 寸法図

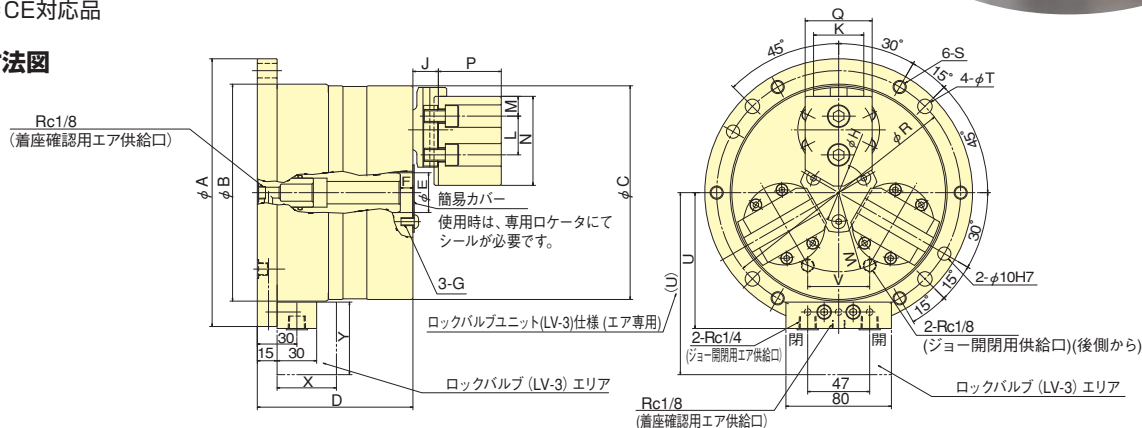

■ 寸法表

※(U), X, Yの寸法はLV-3(ロックバルブ)の寸法である。

寸法	A	B	C	D	E	F	G	H	J	K	L	M	N	P	Q	R	S	T	U	(U)	V	W	X	Y
型式	h7				+0.02/0	min	M6 深12									(±0.2)								
PWS06	203	164.5	162	118	30.17	5.5		44	19.3	38.07	29.36	15	67.5	47.7	50.8	185	M10	11	103	138	47	60	45	55

■ 仕様表

※把握力はジョーおよびワークの把握部状態により変化します。 ※空気消費量はプランジャストローク5mm当たり、圧力0.6MPa時
※把握径/把握範囲は標準のソフトジョーを使用した場合。

仕様	プランジャストローク mm	ジョーストローク (直径) mm	把握力 kN		許容最大圧力 MPa		最低使用圧力 MPa	把握径 mm				質量 (標準ソフトジョー付) kg	空気消費量 (N ₂)
			エア圧力 0.6MPa	油圧力 1.3MPa	MPa			Max. Min.		Max. Min.			
					エア圧力	油圧力		Max.	Min.	Max.	Min.		
型式					0.7	1.3	0.2	120	13	160	70	24	0.54

■ 作動位置寸法図 (外径把握時)

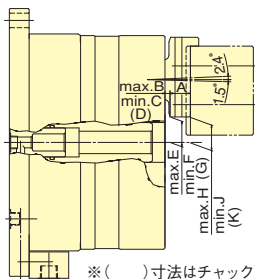

※()寸法はチャック面とソフトジョートリツケ面が平行の場合を示す。

■ 作動位置寸法表 (外径把握時)

寸法	A	B	C	D	E	F	G	H	J	K
型式										
PWS06	15.50	4.96	3.05	3.80	20.06	18.89	19.33	20.70	18.48	19.33

■ 作動位置寸法図 (内径把握時)

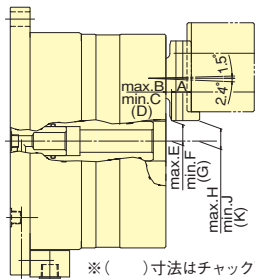

※()寸法はチャック面とソフトジョートリツケ面が平行の場合を示す。

■ 作動位置寸法表 (内径把握時)

寸法	A	B	C	D	E	F	G	H	J	K
型式										
PWS06	15.03	5.59	3.43	4.27	16.28	15.08	15.53	17.17	14.52	15.53



WORK GRIPPER

Power Wing Work Gripper PWS06

Suitable for 3 to 5-Axis machines

Cost reduction achieved by built-in Cylinder

- Stationary clamping by pull back the work-pieces
Suitable for rough machining, OP-10 or OP-20 with reduced setup time.
- Cost reduction achieved by built-in Cylinder
*No need to introduce separated Cylinder for Chuck.
- Available on the standard column of machine
*Total height is reduced by built-in Cylinder.
- Available to be mounted on NC Rotary Table
- By using the optional lock valve unit, it is possible to remove the piping during machining

*Provide a lubricator in the piping circuit.

*CE corresponding



Dimensional Drawings

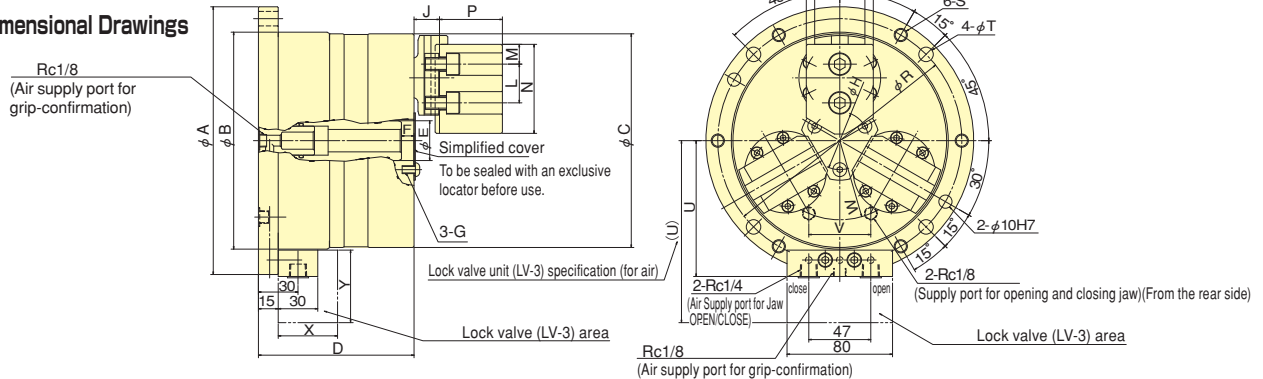

Dimensions

*The dimensions of (U)/X/Y marked are the size of LV-3(Lock-valve).

Dimensions	A	B	C	D	E	F	G	H	J	K	L	M	N	P	Q	R	S	T	U	(U)	V	W	X	Y
Model	h7				+0.02 0	min	M6 Depth 12									(±0.2)								
PWS06	203	164.5	162	118	30.17	5.5		44	19.3	38.07	29.36	15	67.5	47.7	50.8	185	M10	11	103	138	47	60	45	55

*Clamping force varies in clamping state for jaws and work-pieces. *Air Consumption = Under Pressure 0.6MPa Plunger Stroke per 5mm

*Gripping dia./gripping range is with standard soft jaws.

Specifications

Specifications	Plunger Stroke mm	Jaw Stroke (diameter) mm	Gripping Force kN		Max. allowable pressure MPa		Min. allowable pressure MPa	Gripping range mm				Net Weight with Soft top jaws kg	Air consumption (N _l)
			Pneumatic at 0.6MPa	Hydraulic at 1.3MPa	Pneumatic	Hydraulic		external φ		Internal φ			
Model								Max.	Min.	Max.	Min.		
PWS06	11.1	7.7	19	53	0.7	1.3	0.2	120	13	160	70	24	0.54

Dimensional Drawing for actuated position (External Gripping)

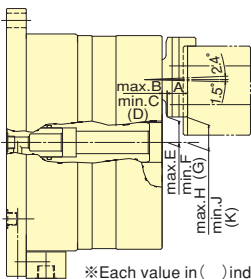

*Each value in () indicate that surface of chuck and Jaw mounting side is parallel.

Dimensions for actuated position (External Gripping)

Dimensions	A	B	C	D	E	F	G	H	J	K
Model										
PWS06	15.50	4.96	3.05	3.80	20.06	18.89	19.33	20.70	18.48	19.33

Dimensional Drawing for actuated position (Internal Gripping)

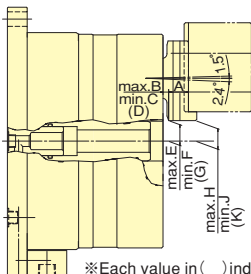

*Each value in () indicate that surface of chuck and Jaw mounting side is parallel.

Dimensions for actuated position (Internal Gripping)

Dimensions	A	B	C	D	E	F	G	H	J	K
Model										
PWS06	15.03	5.59	3.43	4.27	16.28	15.08	15.53	17.17	14.52	15.53



WORK GRIPPER

内径プルロックワークグリッパ

PUES06

**旋盤用チャックがM/C用に変身
シリンダ内蔵でコストダウン
オプションジョーの使用で把握範囲拡大**

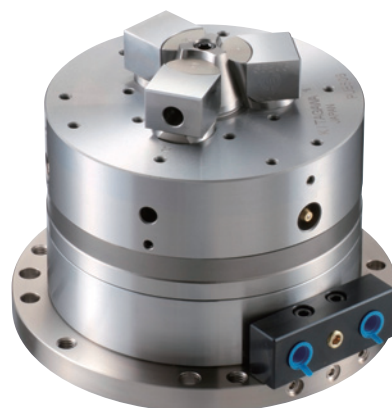

- ワーク内径を引込把握
抜群の安定精度で仕上げ工程に最適
- シリンダ内蔵で導入コストダウン
別途チャック作動用シリンダが不要
- 機械標準コラム仕様で対応可能
シリンダ内蔵で全高を低く抑えました
- NC円テーブルにスムーズ搭載
ワークに合わせた最適な把握をご提案します
- オプションジョーの使用で把握範囲拡大
- オプションのロックバルブユニット使用により、
配管を外して加工可能

※配管回路にルブリケータを設けてください。

*CE対応品

■ 寸法図

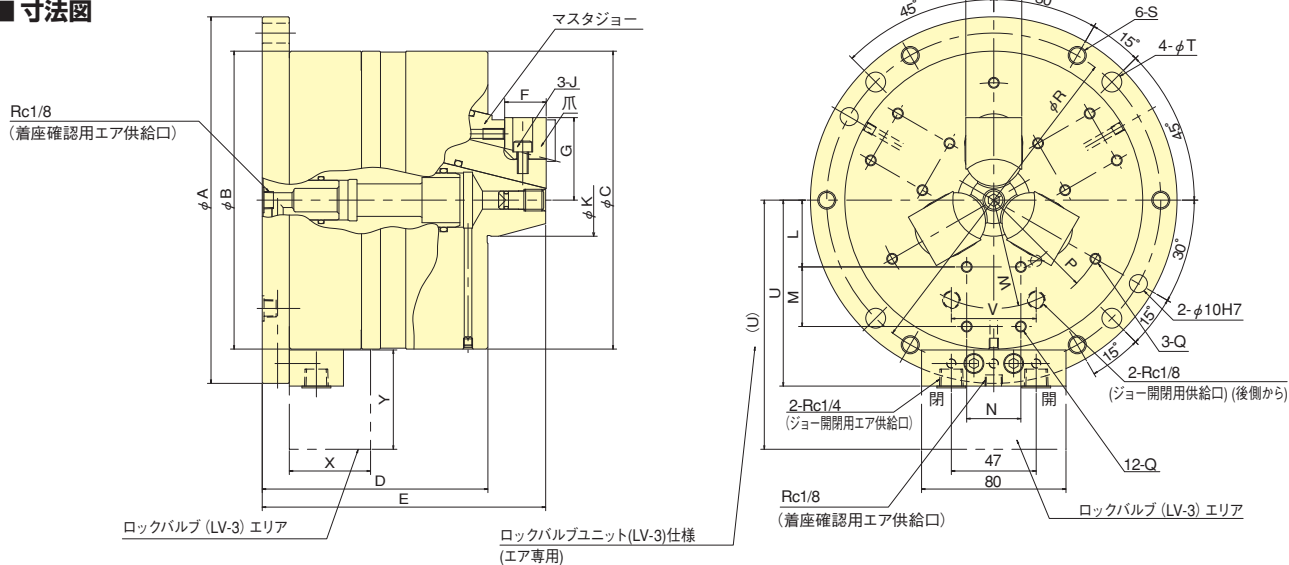

※ジョー開でワーク内径をクランプします。

■ 寸法表 ※(U),X,Yの寸法はLV-3(ロックバルブ)の寸法である。

型式	寸法		A _{h7}	B	C	D	E	F	G		H	J	K	L	M	N	P	Q	R _(±0.2)	S	T	U	(U)	V	W	X	Y
	max.	min.																									
PUES06	203	165	165	125	157	23	46.9	44.5	31	M6	40	37	33	30	65	M6 深11	185	M10	11	103	138	47	60	45	55		

■ 仕様表 ※把握力はジョーおよびワークの把握部状態により変化します。 ※空気消費量はプランジャストローク5mm当たり、圧力0.6MPa時

型式	仕様	プランジャストローク mm	ジョーストローク (直径) mm	把握力 kN		許容最大圧力 MPa		最低使用圧力 MPa	把握範囲 mm			質量 (標準ソフトジョー付) kg	空気消費量 (N _l)
				エア圧力 0.6MPa	油圧力 1.3MPa	エア圧力	油圧力		標準ジョー	オプションジョー	マスタジョー 把握		
PUES06		10.3	4.8	20	57	0.7	1.3	0.2	φ70~φ87	φ89~φ108	φ44~φ70	21	0.54



WORK GRIPPER

Internal Pull Lock Work Gripper PUES06

Suitable for 3 to 5-Axis machines
Cost reduction achieved by built-in Cylinder
Wide gripping range with the use of optional jaws

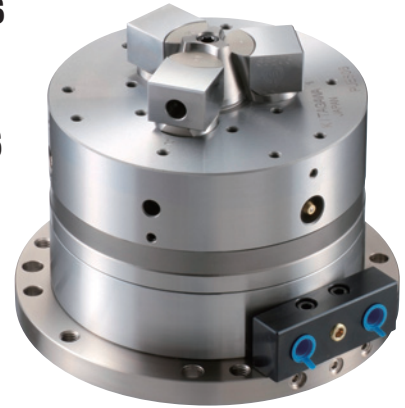

- Pull back and clamping the inner diameter of work-pieces
Suitable for finish machining with stationary machining accuracy.
- Cost reduction achieved by built-in Cylinder
No need to introduce separated Cylinder for Chuck.
- Available on the standard column of machine
Total height is reduced by built-in Cylinder.
- Wide gripping range with the use of optional jaw
- By using the optional lock valve unit, it is possible to remove the piping during machining

※Provide a lubricator in the piping circuit.

*CE corresponding

Dimensional Drawings

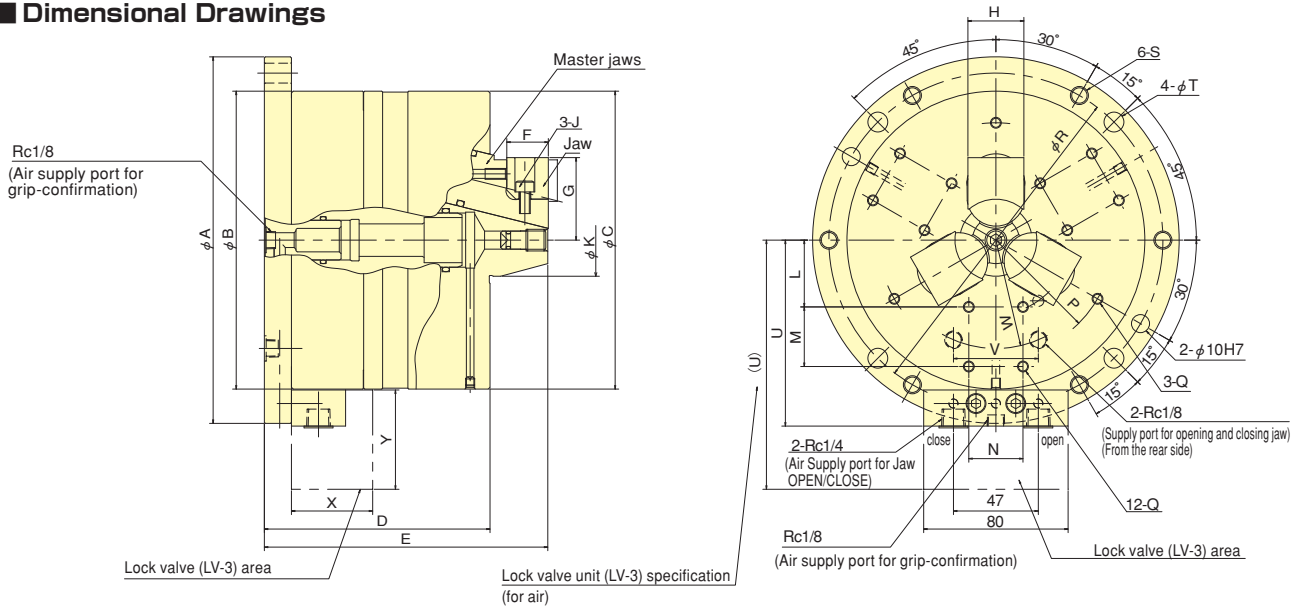

※By opening jaws the chuck clamps ID of the workpiece.

Dimensions

※The dimensions of (U)/X/Y marked are the size of LV-3(Lock-valve).

Model	A		B	C	D	E	F	G		H	J	K	L	M	N	P	Q	R (±0.2)	S	T	U	(U)	V	W	X	Y
	h7	h7						max.	min.																	
PUES06	203	165	165	125	157	23	46.9	44.5	31	M6	40	37	33	30	65	M6 Depth 11	185	M10	11	103	138	47	60	45	55	

Specifications

※Clamping force varies in clamping state for jaws and work-pieces. ※Air Consumption = Under Pressure 0.6MPa Plunger Stroke per 5mm

Model	Plunger Stroke mm	Jaw Stroke (diameter) mm	Gripping Force kN		Max. allowable pressure MPa		Min. allowable pressure MPa	Gripping range mm			Net Weight with Soft top jaws kg	Air consumption (N _l)
			Pneumatic at 0.6MPa	Hydraulic at 1.3MPa	Pneumatic	Hydraulic		Standard jaws	Option jaws	Master jaws		
PUES06	10.3	4.8	20	57	0.7	1.3	0.2	φ70~φ87	φ89~φ108	φ44~φ70	21	0.54

ワークグripper



WORK GRIPPER

プルロックワークグリッパ

PLS series

引込みで安定把握

M/C関係のワークホールディングもKITAGAWA

- 高精度、高把握力で安定した切削加工ができます
- 着座確認に対応できるため、自動化に対応できます
- シリンダ内蔵、低床、省スペース設計により加工範囲が広がります
- オプションのロックバルブユニット使用により、配管を外して加工可能

※配管回路にルブリケータを設けてください。
 ※CE対応品



■ 寸法図

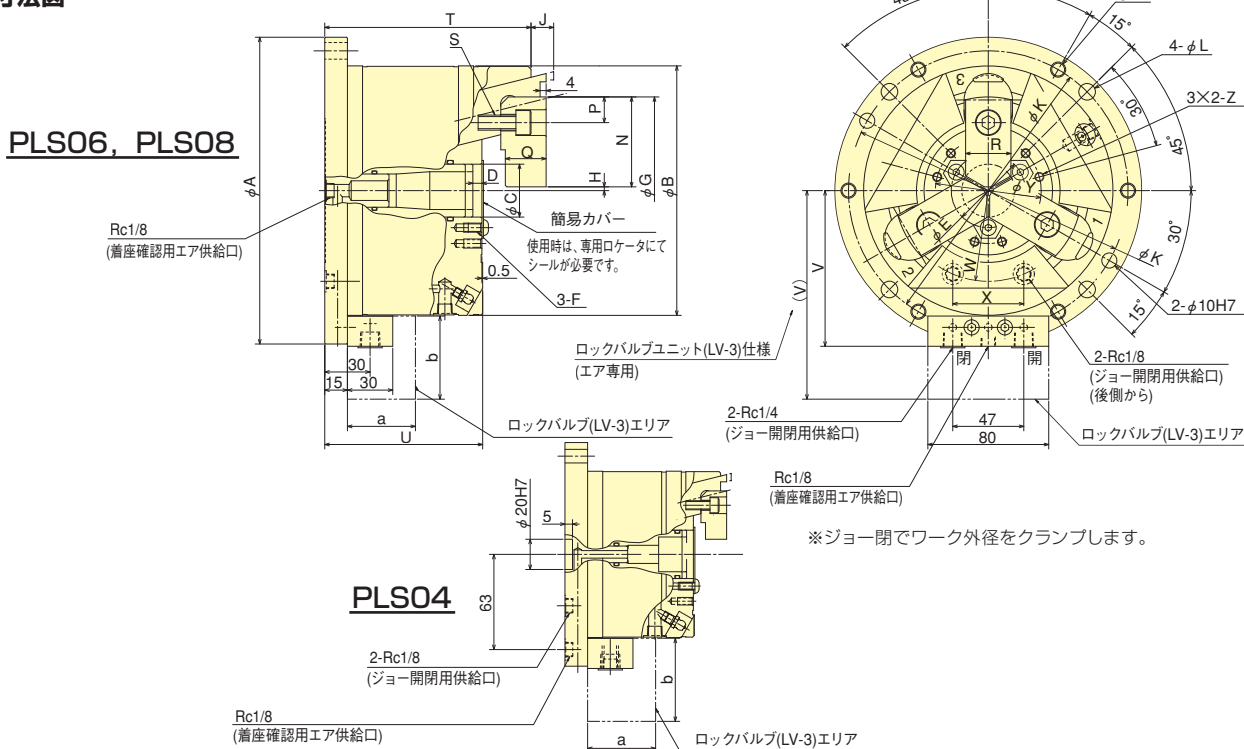

■ 寸法表

※(V), a, bの寸法はLV-3(ロックバルブ)の寸法である。

寸法	A (h7)	B(0.1)	C(0.01)	Dmin.	E	F	G(H6)	Hmax.	Hmin.	J max.	J min.	K (±0.2)	L	M	N
型式															
PLS04	148	110.1	32	4.5	42	M5 深 10	84	2.25	0.75	7	1	130	9	M 8	40.5
PLS06	203	165.1	35	6.0	49	M6 深 12	124	3.75	1.25	15	5	185	11	M10	59.5
PLS08	248	210.1	55	6.0	71	M6 深 12	154	3.75	1.25	17	7	230	11	M10	74.5

寸法	P	Q	R	S	T	U	V	(V)	W	X	Y	Z	a	b
型式														
PLS04	9.5	14	20	M 6	103	85.5	75.5	110.5	34	33	62	M5 深 10	45	55
PLS06	17	27	30	M10	136.5	104.5	103	138	60	47	70	M6 深 12	45	55
PLS08	20.5	31	35	M12	155.5	118.5	125.5	160.5	80	47	95	M6 深 12	45	55

■ 仕様表

※把握力はジョーおよびワークの把握部状態により変化します。 ※空気消費量はプランジャストローク5mm当り、圧力0.6MPa時
 ※把握径/把握範囲は標準のソフトジョーを使用した場合。

型式	仕様	プランジャストローク mm	ジョーストローク (直密) mm	把握力 kN				許容最大圧力 MPa		最低使用圧力 MPa	把握径 mm		質量 (標準ソフトジョー付) kg	空気消費量 (N ₀)
				エア圧力 0.6MPa時		油圧力 1.3MPa時		エア圧力	油圧力		Max.	Min.		
				ソフトジョー使用時	焼入れジョー使用時	ソフトジョー使用時	焼入れジョー使用時							
PLS04		6	3	6.7	7.4	16.0	17.4	0.7	1.3	0.2	φ50	φ5	7.4	0.22
PLS06		10	5	18.5	22.0	40.0	45.0				φ69	φ8	18.0	0.54
PLS08		10	5	37.0	40.0	80.0	84.0				φ89	φ8	33.0	0.93



WORK GRIPPER

Pull Lock Work Gripper

PLS series

Pull Lock for steady gripping

Stable cutting is guaranteed through the high precision and exceptional gripping performance. Can be used as alternative to a fixture



- Stable cutting is performed by high precision and high gripping force
- Perfect for CNC machining applications, thanks to component detection feature
- It's compact design, featuring an inbuilt cylinder allows for more space in the machining envelope
- By using the optional lock valve unit, it is possible to remove the piping during machining

※Provide a lubricator in the piping circuit.

*CE corresponding

Dimensional Drawings

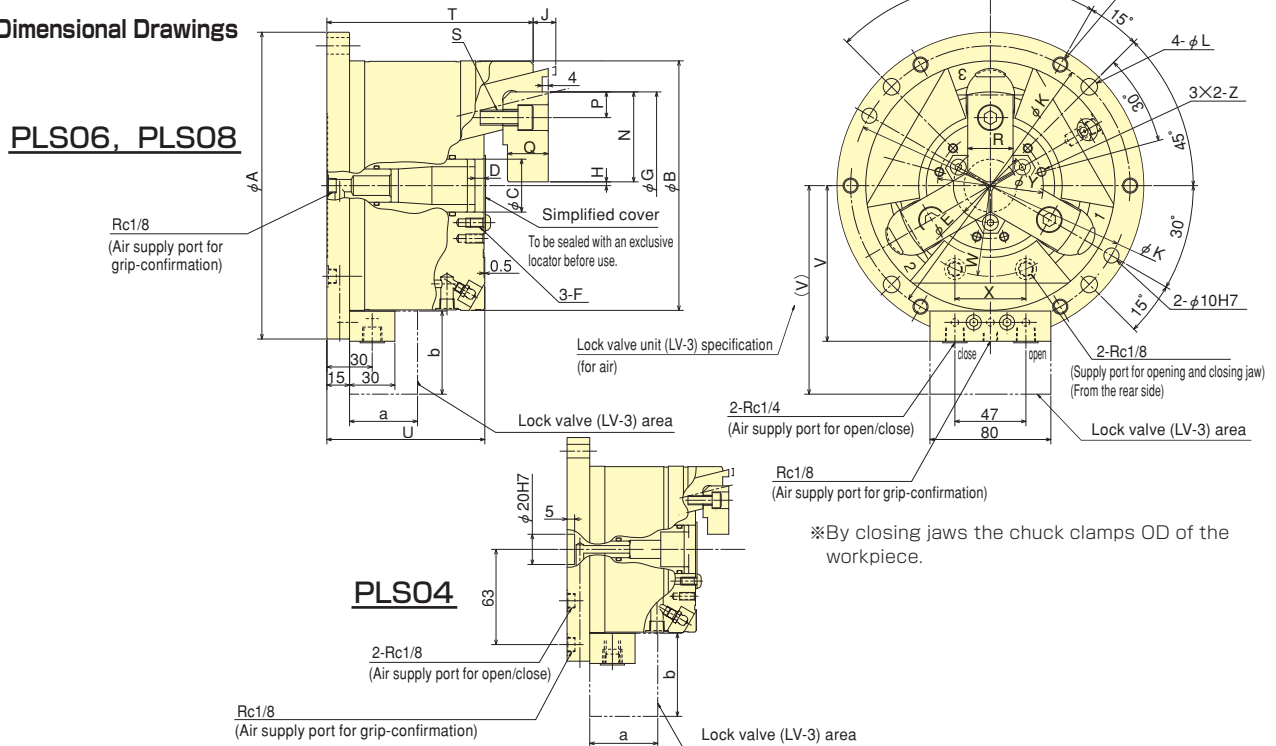

Dimensions

※The dimensions of a/b marked are the size of LV-3(Lock-valve).

Dimensions	A (h7)	B (0.1)	C (0.01)	D min.	E	F	G (H6)	H max.	H min.	J max.	J min.	K (±0.2)	L	M	N
Model PLS04	148	110.1	32	4.5	42	M5 Depth 10	84	2.25	0.75	7	1	130	9	M 8	40.5
Model PLS06	203	165.1	35	6.0	49	M6 Depth 12	124	3.75	1.25	15	5	185	11	M10	59.5
Model PLS08	248	210.1	55	6.0	71	M6 Depth 12	154	3.75	1.25	17	7	230	11	M10	74.5

Dimensions	P	Q	R	S	T	U	V	(V)	W	X	Y	Z	a	b
Model PLS04	9.5	14	20	M 6	103	85.5	75.5	110.5	34	33	62	M5 Depth 10	45	55
Model PLS06	17	27	30	M10	136.5	104.5	103	138	60	47	70	M6 Depth 12	45	55
Model PLS08	20.5	31	35	M12	155.5	118.5	125.5	160.5	80	47	95	M6 Depth 12	45	55

Specifications

※Clamping force varies in clamping state for jaws and work-pieces. ※Air Consumption = Under Pressure 0.6MPa Plunger Stroke per 5mm
 ※Gripping dia./gripping range is with standard soft jaws.

Specifications	Plunger Stroke mm	Jaw Stroke (diameter) mm	Gripping Force kN				Max. allowable pressure MPa		Min. allowable pressure MPa	Gripping range mm		Net Weight with Soft top jaws kg	Air consumption (N ϕ)
			Pneumatic at 0.6MPa		Hydraulic at 1.3MPa		Pneumatic	Hydraulic		Max.	Min.		
			Use of soft jaw	Use of hardened jaw	Use of soft jaw	Use of hardened jaw							
Model PLS04	6	3	6.7	7.4	16.0	17.4	0.7	1.3	0.2	ϕ 50	ϕ 5	7.4	0.22
Model PLS06	10	5	18.5	22.0	40.0	45.0				ϕ 69	ϕ 8	18.0	0.54
Model PLS08	10	5	37.0	40.0	80.0	84.0				ϕ 89	ϕ 8	33.0	0.93

ワークグripper
Work Gripper



WORK GRIPPER

ジグモジュール

JM200

異形ダイカストワークも確実把握

多種類のワークに対応する新しいクランプシステム

- ロックバルブ機構(オプション)が組み込み可能のため、エアを切り離してもワークが保持できます
- センタリングとコンペセイティングの切替が出来ます
- フェイスクランプ(端面把握)が可能です
- 着座確認が可能な為、自動化に対応出来ます

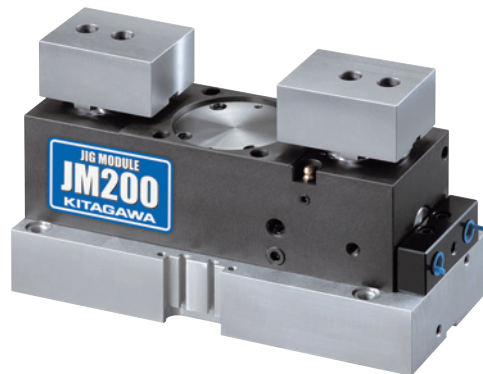

3つの把握機能が1台で対応できます。

求心把握 センタライジング

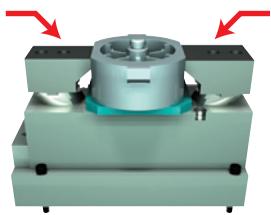

引き込みによる外部把握

心補償把握 コンペセイティング

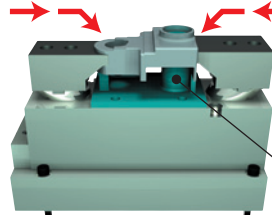

基準位置ピン&引き込みによる把握

端面把握 フェイスクランプ

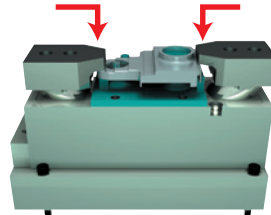

引き込みによる端面把握

着座確認対応可能

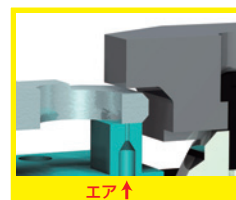

■ 寸法図

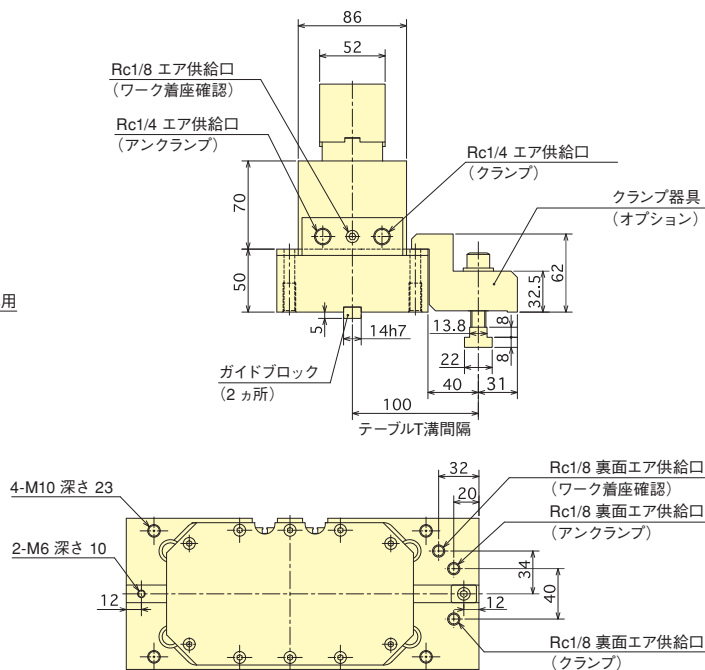
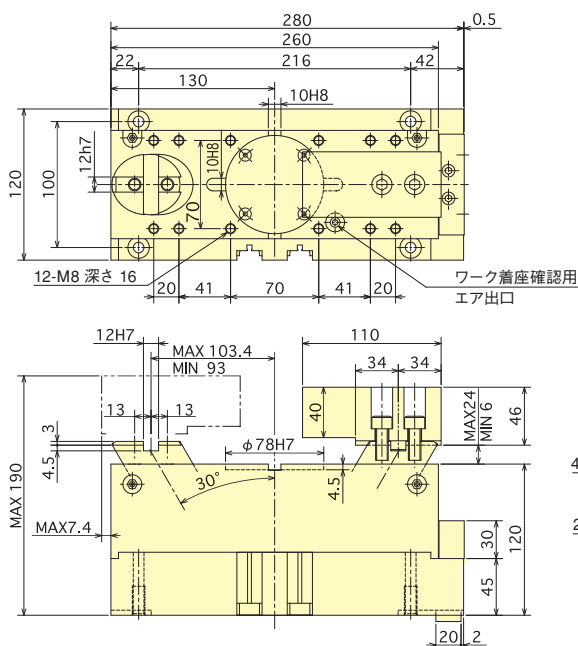

※本体取付用のクランプ金具はオプションとなります。

■ 仕様表

シリンダストローク mm	ジョーストローク mm		最大把握力 kN		最低把握力 kN		最大揺動量 mm		ワークサイズ mm		質量 kg	許容最大エア圧力 MPa	最低使用エア圧力 MPa
	センタリング・コンペ	フェイスクランプ	センタリング・コンペ	フェイスクランプ	センタリング・コンペ	フェイスクランプ	センタリング・コンペ	フェイスクランプ	センタリング・コンペ	フェイスクランプ			
18	20.8	18	9.0	5.5	3.0	1.8	1.5	2.5	40~200	40~150	19.0	0.6	0.2



WORK GRIPPER

Jig Module JM200

Securely grips a wide range of irregularly shaped components
New clamping system accommodates a variety of work-pieces

- Option of lock valve mechanism meaning that during machining work-pieces can be held without air line
- Centralizing or compensating is switchable
- Face grip (end grip) is possible
- Seating confirmation can be checked automatically

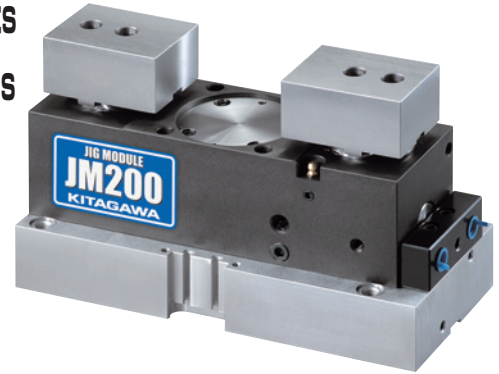

One unit is equipped with three gripping functions.

Centralizing Grip **Centralizing**

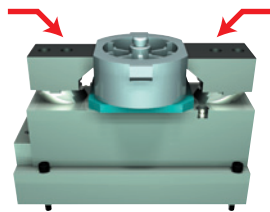

External gripping by pull down

Center compensation grip **Compensating**

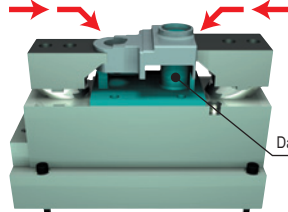

Compensating gripping using pin locators and pull down

End face grip **Face Grip**

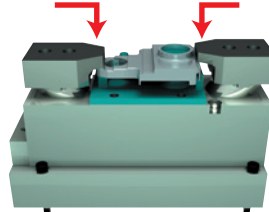

Face gripping by pull down

Seating confirmation can be checked

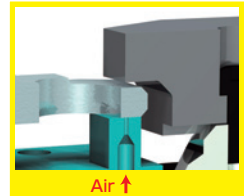

Dimensional Drawings

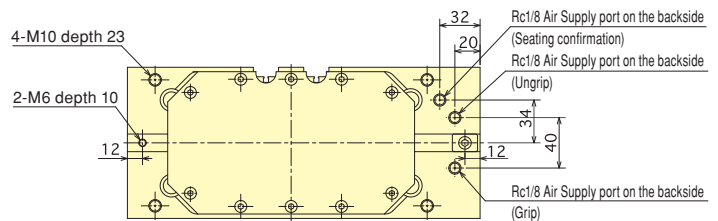
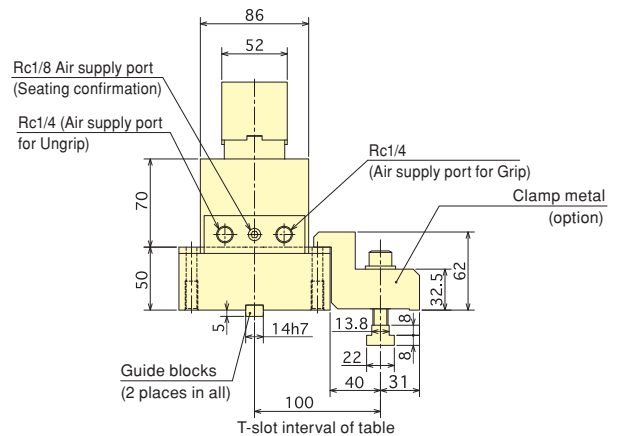
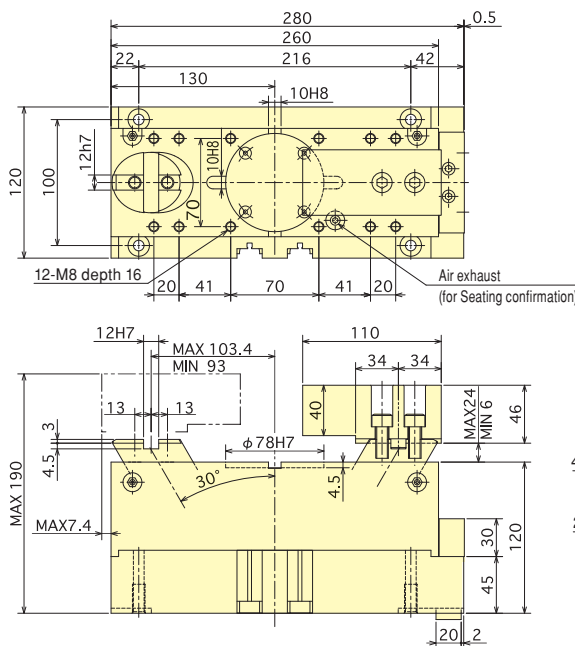

Note : Grip metals for mounting main part can be optionally offered.

Specifications

Cylinder Stroke mm	Jaw Stroke mm		Max. Gripping Force kN		Min. Gripping Force kN		Max. Oscillating amount mm		Work-piece size mm		Net Weight kg	Max. air pressure MPa	Min. air pressure MPa
	Centring/Compensation	Face grip	Centring/Compensation	Face grip	Centring/Compensation	Face grip	Centring/Compensation	Face grip	Centring/Compensation	Face grip			
18	20.8	18	9.0	5.5	3.0	1.8	1.5	2.5	40~200	40~150	19.0	0.6	0.2



WORK GRIPPER

スクロールワークグリッパ

SC-S series

安心、安定、使い易い ステーションナリスクロールチャック

- 複数セッティングでも個々の位置設定は自在
- 狭いスペースにもセッティング可能
- 多様なワークに対応できる、爪分割式のソフトジョー仕様
- 使い易い専用ハンドル付

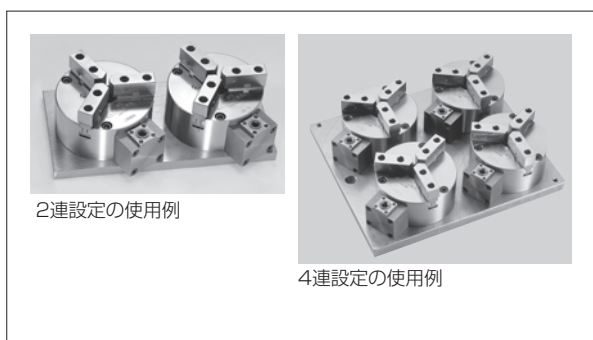

■ 寸法図

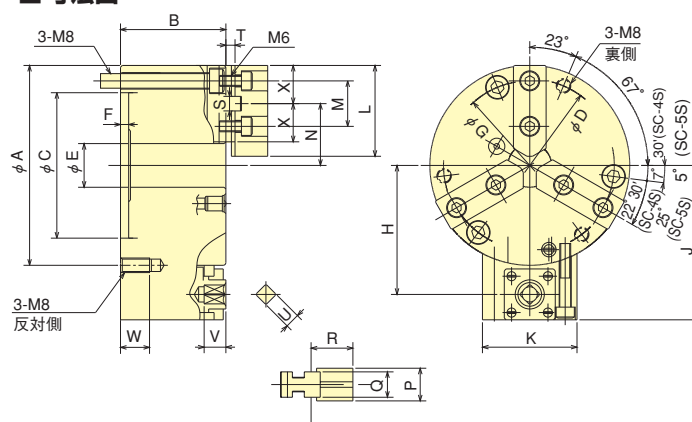

■ 仕様表 ※把握径/把握範囲は標準のソフトジョーを使用した場合。

型式	仕様	最大静的把握力 kN	許容ハンドルトルク N・m	質量 kg	把握範囲	
					外径 φ mm	内径 φ mm
SC-4S		9.6	27.5	4.0	3~95	29~84
SC-5S		12.0	39.2	5.3	3~110	33~100

■ 寸法表

型式	寸法	A	B	C (H6)	D	E	F	G	H	J	K	L	M	Nmin	Nmax	P	Q	R	S	T	U	V	W	X
		SC-4S	110	58	80	95	24	4.5	93	71	85	52	50	25	26	37	18	14	23	8	5	8	12	16
SC-5S	130	60	100	115	32	4.5	113	81	95	56	60	30	30	45	20	16	26	8	6	8	12	16	25	

■ ソフトジョー寸法図

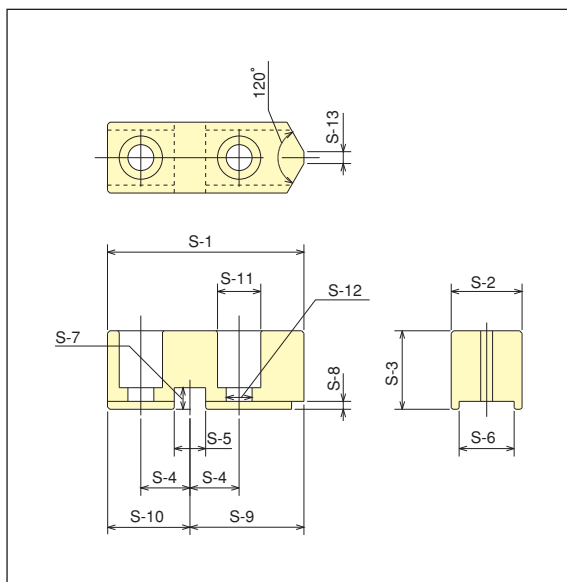

■ ソフトジョー寸法表

型式	寸法	チャック サイズ	S-1	S-2	S-3	S-4 ±0.1	S-5 +0.01 0	S-6 +0.05 +0.02
			SBS04S	4	50	18	20	12.5
SBS05S	5	60	20	22	15	8	16	

型式	寸法	S-7	S-8	S-9	S-10	S-11	S-12	S-13
		SBS04S	5.5	2	29	21	11	6.6
SBS05S	5.5	2	35	25	11	6.6	3	

■ ハンドル寸法図

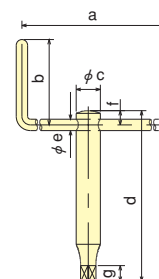

■ ハンドル寸法表

型式	寸法	a	b	c	d	e	f	g
		SC-4S	130	60	17	120	8	10
SC-5S	150	60	20	130	10	12	11	



WORK GRIPPER

Stationary Scroll Chuck

SC-S series

Durable, reliable and versatile Stationary scroll chuck

- Available on multiplate for easy fixture mounting
- Compact designed
- Soft jaw can be machined to adapt to a wide range of machine work-pieces
- Uses exclusive handle for clamping



2 chuck fixture sample



4 chuck fixture sample

Dimensional Drawings

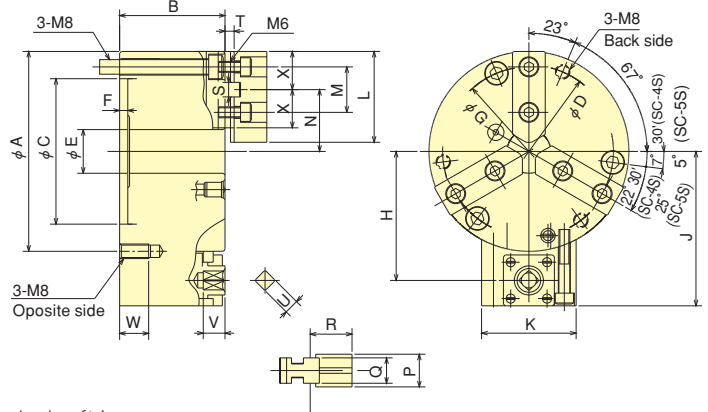

Specifications ※Gripping dia./gripping range is with standard soft jaws.

Model	Specifications	Max. Gripping Force kN	Allowable handle torque N·m	Net Weight kg	Gripping range	
					external ϕ mm	internal ϕ mm
SC-4S		9.6	27.5	4.0	3~95	29~84
SC-5S		12.0	39.2	5.3	3~110	33~100

Dimensions

Model	Dimensions																						
	A	B	C (H6)	D	E	F	G	H	J	K	L	M	Nmin	Nmax	P	Q	R	S	T	U	V	W	X
SC-4S	110	58	80	95	24	4.5	93	71	85	52	50	25	26	37	18	14	23	8	5	8	12	16	21
SC-5S	130	60	100	115	32	4.5	113	81	95	56	60	30	30	45	20	16	26	8	6	8	12	16	25

Dimensional Drawings for Soft Jaw

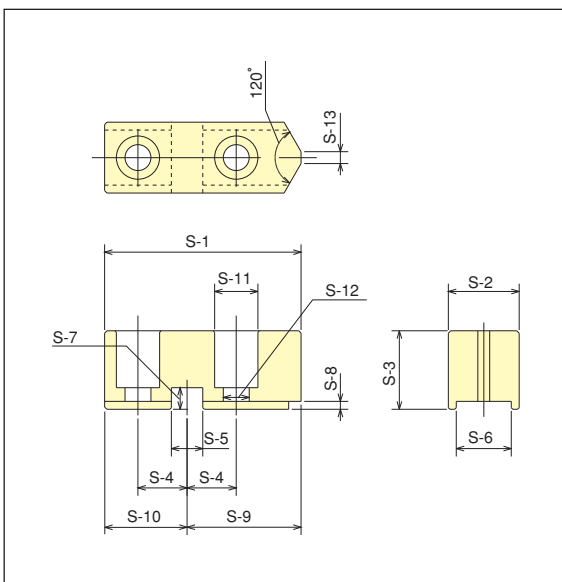

Dimensions for Soft Jaws

Model	Dimensions	chuck size	S-1	S-2	S-3	S-4	S-5	S-6
						± 0.1	0	$+0.05$ $+0.02$
SBS04S		4	50	18	20	12.5	8	14
SBS05S		5	60	20	22	15	8	16

Model	Dimensions	S-7	S-8	S-9	S-10	S-11	S-12	S-13
		SBS04S	5.5	2	29	21	11	6.6
SBS05S	5.5	2	35	25	11	6.6	3	

Dimensional Drawings for Handle

Dimensions for Handles

Model	Dimensions						
	a	b	c	d	e	f	g
SC-4S	130	60	17	120	8	10	11
SC-5S	150	60	20	130	10	12	11

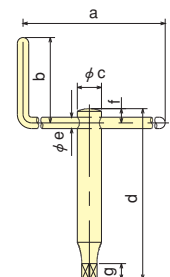



WORK GRIPPER

オプション Option

LV-3

■ エアロックバルブユニット (エア専用)
Air Lock Valve Unit

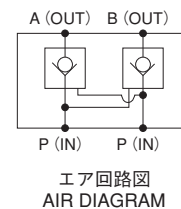
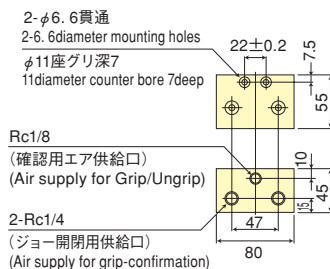
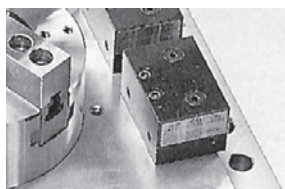

AV-02S

■ エア手動切換弁
Original manual air valve

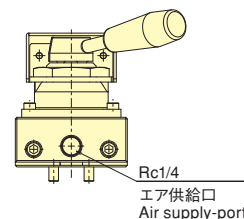
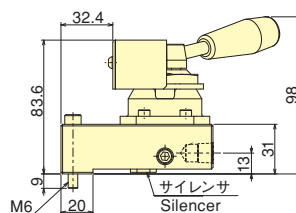
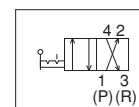
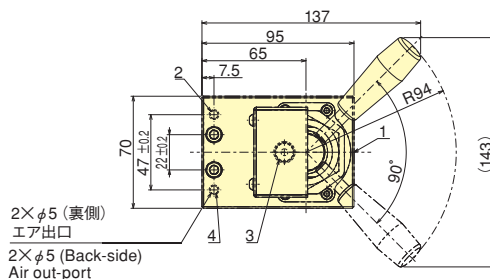
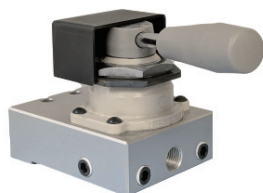

AV-02Sは空気配管をシンプルにする。
AV-02S allows air system to be simplified

- ※ワークグリッパ、マルチプレートに簡単に取付けできます。
- ※ Valves can be easily mounted onto work gripper and multiplate.

■ 取り付け図面 (AV-02S) Mounting Drawing (by AV-02S)

最大許容圧力 Max. pressure	0.7MPa
操作角度 Lever movement	90°
接続口径 Connection port	Rc 1/4

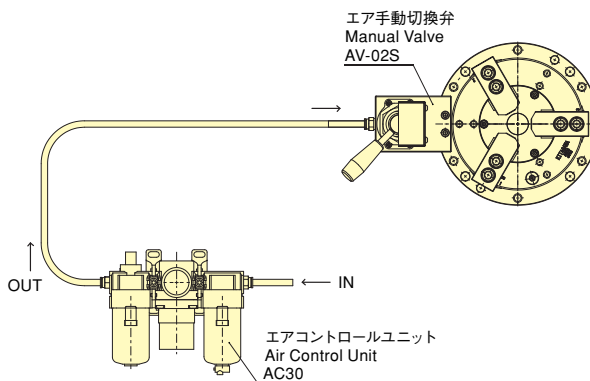
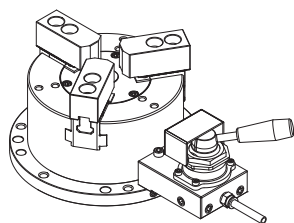

VH201-02

■ エア手動切換弁
Original manual air valve



最大許容圧力 Max. pressure	1MPa
操作角度 Lever movement	90°
接続口径 Connection port	Rc 1/4

■ 取り付け図面 (VH201-02)
Mounting Drawing (by VH201-02)

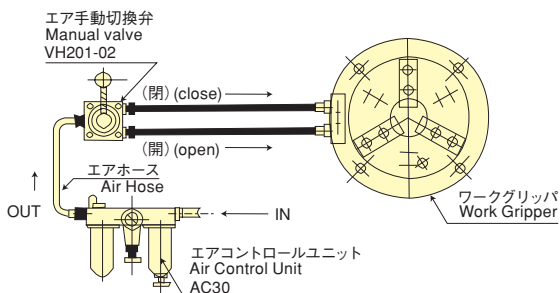

AC30

■ エアコントロールユニット
(潤滑装置付き)
Air Control Unit
(With Lubrication)

最大許容圧力 Max. pressure	1MPa
圧力設定範囲 Pressure setting range	0.05~0.85MPa
濾過精度 Filter mesh	5μm
最高使用温度 Max. temperature	60°C
接続口径 Connection port	Rc 1/4



CHUCK

▶ P.111~P.136

部品・その他
Jaws and Accessories



CHUCK

パワーチャック用ソフトジョー Soft Jaws for Power Chuck

SJ series



※SJシリーズは従来型ソフトジョー SBシリーズのモデルチェンジ品であり、SBシリーズと完全互換性があります。
ご不明な点がございましたら、弊社の担当営業員までお問い合わせください。

※SJ series is a model change type of existing SB series and it is fully compatible with SB series.
If you have any questions, please consult us.

型式表示 Description of Model

SJ 06A1-80

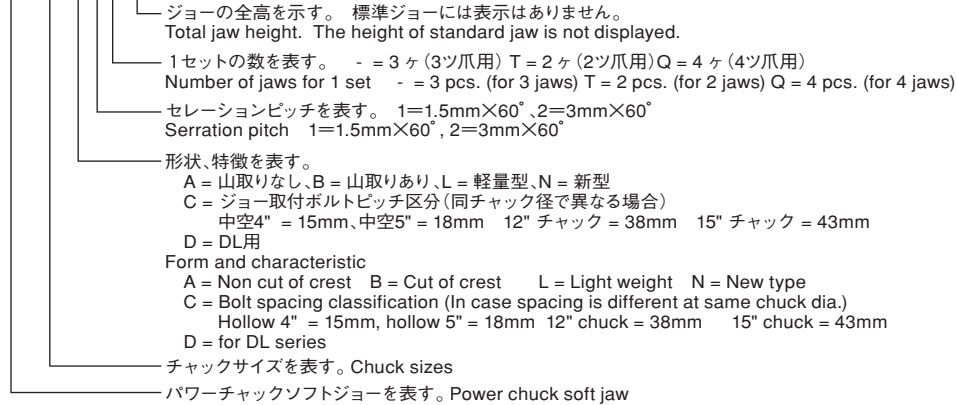

ソフトジョー兼用表 Combination of Soft Jaws

標準爪型式 Standard jaw	高爪型式 High jaw	適応中実チャック型式 Adaptive closed centre chuck	適応中空チャック型式 Adaptive open centre chuck
SJ04B1	SJ04A1-036	SJ04A1-048	N-04, AS04, NL04, NRC04
SJ04A1T	SB04A1T036	SJ04A1T048	NT04, AT04
SJ04N1	SJ04N1-036	SJ04N1-048	
SJ04N1T	SJ04N1T036	SJ04N1-048	B-204 BT204
SJ05B1	SJ05A1-038	SJ05A1-053	N-05
SJ05A1T	SJ05A1T038	SJ05A1T053	NT05
SJ05N1	SJ05N1-038	SJ05N1-053	
SJ05N1T	SJ05N1-038	SJ05N1T-53	BR05, B-205 BT205
SJ06B1	SJ06A1-066		N-06, NL06, AS06, NRC06, HRS08 BR06, BB206, QJR07, DLR08
SJ06A1T	SJ06A1T066		NLT06, AT06 BRT06, BBT206
SJ06C1			UVE160K
SJ06D1	SJ06D1-066		DL206
SJ06L1A	SJ06A1-066		B-206, BS306, BL206, HOH-206
SJ06L1T	SJ06A1T066		BT206, BLT206
SJ08A1	SJ08A1T056	SJ08A1T076	NLT08, AT08 BRT08, BT208, BBT208, BLT208
SJ08B1	SJ08A1-056	SJ08A1-076	N-08, NL08, DL208, AS08, NRC08 BR08, B-208, BB208, BS308, BL208, HOH-208, QJR08
SJ08B1Q		SJ08B1Q-76	HW-08
SJ10A1	SJ10A1-056	SJ10A1-080 SJ10A1T080	SJ10A1-116 NL10, AS10, NRC10 NLT10, AT10 BRT10, BT210, BBT210, BLT210
SJ10B1	SJ10A1-056	SJ10A1-080	SJ10A1-116 N-10 BR10, B-210, BB210, BS310, BL210, HOH-10K, QJR10, UVE200K, UVE250K
SJ10A2Q	SJ10A2Q080		HW-10, HW-12
SJ10D1			DL210
SJ12A1	SJ12A1-090 SJ12A1T090		N-12, NL12, DL212 NLT12 HOH-12K
SJ12C1			UVE315K
SJ12N1	SJ12N1-090		BR12, B-212, BB212, BL212, QJR12, BT212, BBT212, BLT212, BRT12
SJ15C1	SJ15C1-110		B-15, B-18, HOH-15K
SJ15A2			UVE400K
SJ15A2Q			HW-15
SJ15N1	SJ15N1-110		N-15, N-18 B-215
SJ18A2	SJ18A2-110		N-21, N-24 B-21, B-24
SB06BB	SB06BB-040		QB306
SB08BB	SB08BB-056		QB308
SB10BB	SB10BB-060		QB310
SB12BB	SB12BB-070		QB312
SBW06			PW-06
SBW08			PW-08
SBW10			PW-10
SBW12			PW-12
SBW15			PW-15, PW-21

■ 標準ソフトジョー組合せ表

Combination Table for Standard Soft Jaws

チャック型式 Chuck	ソフトジョー型式 Soft jaw	取付ボルト Mounting bolt	チャック型式 Chuck	ソフトジョー型式 Soft jaw	取付ボルト Mounting bolt
BR05	SJ05N1	M8×20	NL04	SJ04B1	M8×22
BR06	SJ06B1	M10×25	NL06	SJ06B1	M10×30
BR08	SJ08B1	M12×30	NL08	SJ08B1	M12×35
BR10	SJ10B1	M12×30	NL10	SJ10A1	M12×35
BR12	SJ12N1	M16×35	NL12	SJ12A1	M14×45
			NL18	SJ15N1	M20×55
B-204	SJ04N1	M8×20			
B-205	SJ05N1	M8×20	NT04	SJ04A1T	M8×22
B-206	SJ06L1A	M10×25	NT05	SJ05A1T	M8×22
B-208	SJ08B1	M12×30	NT15	SJ12N1	M20×55
B-210	SJ10B1	M12×30			
B-212	SJ12N1	M16×40	NLT06	SJ06A1T	M10×25
B-215	SJ15N1	M20×55	NLT08	SJ08A1	M12×30
			NLT10	SJ10A1	M12×35
			NLT12	SJ12A1	M14×45
B-15	SJ15C1	M20×60			
B-18	SJ15C1	M20×60			
B-21	SJ18A2	M20×60	ML06	SJ06B1	M10×25
B-24	SJ18A2	M20×60	ML08	SJ08B1	M12×30
BB206	SJ06B1	M10×25	MLT06	SJ06A1T	M10×25
BB208	SJ08B1	M12×30	MLT08	SJ08A1	M12×30
BB210	SJ10B1	M12×30			
BB212	SJ12N1	M16×35	MLV06	SB06A1V	M10×25
			MLV08	SB08A1V	M12×30
BS306	SJ06L1A	M10×25			
BS308	SJ08B1	M12×30	HW-08	SJ08B1Q	M10×25
BS310	SJ10B1	M12×30	HW-10	SJ10A2Q	M12×35
			HW-12	SJ10A2Q	M12×35
			HW-15	SJ15A2Q	M14×40
BL206	SJ06L1A	M10×25			
BL208	SJ08B1	M12×30			
BL210	SJ10B1	M12×30	UVE160K	SJ06C1	M12×30
BL212	SJ12N1	M16×40	UVE200K	SJ10B1	M12×30
			UVE250K	SJ10B1	M12×30
			UVE315K	SJ12C1	M14×35
			UVE400K	SJ15A2	M20×45
HOH-206	SJ06L1A	M10×25			
HOH-208	SJ08B1	M12×30			
HOH-10K	SJ10B1	M12×35			
HOH-12K	SJ12A1	M14×45	UB450K	SJ18U2	M20×45
HOH-15K	SJ15C1	M20×55	UB560K	UB560K	M20×45
			UB630K	UB710	M24×60
			UB710K	UB710	M24×60
QB306	SB06BB	-			
QB308	SB08BB	-			
QB310	SB10BB	-	HRS08	SJ06B1	M10×25
QB312	SB12BB	-			
			DLR08	SJ06B1	M10×25
BRT06	SJ06A1T	M12×30			
BRT08	SJ08A1	M12×30	DL206	SJ06D1	M10×25
BRT10	SJ10A1	M16×40	DL208	SJ08B1	M12×30
BRT12	SJ12N1	M16×35	DL210	SJ10D1	M14×40
			DL212	SJ12A1	M14×40
BT204	SJ04N1T	M8×20			
BT205	SJ05N1T	M8×20	PW-06	SBW06	M10×16
BT206	SJ06L1T	M10×25	PW-08	SBW08	M12×20
BT208	SJ08A1	M12×30	PW-10	SBW10	M16×25
BT210	SJ10A1	M12×30	PW-12	SBW12	M16×25
BT212	SJ12N1	M16×40	PW-15	SBW15	M20×30
			PW-21	SBW15	M20×30
BBT206	SJ06A1T	M10×25			
BBT208	SJ08A1	M12×30	AS04	SJ04B1	M8×22
BBT210	SJ10A1	M12×30	AS06	SJ06B1	M10×30
BBT212	SJ12N1	M16×40	AS08	SJ08B1	M12×35
			AS10	SJ10A1	M12×35
BLT206	SJ06L1T	M10×25			
BLT208	SJ08A1	M12×30	AT04	SJ04A1T	M8×22
BLT210	SJ10A1	M12×30	AT06	SJ06A1T	M10×30
BLT212	SJ12N1	M16×40	AT08	SJ08A1	M12×35
			AT10	SJ10A1	M12×35
N-04	SJ04B1	M8×22			
N-05	SJ05B1	M8×22	NRC04	SJ04B1	M8×22
N-06	SJ06B1	M10×30	NRC06	SJ06B1	M10×30
N-08	SJ08B1	M12×35	NRC08	SJ08B1	M12×35
N-10	SJ10B1	M12×35	NRC10	SJ10A1	M12×35
N-12	SJ12A1	M14×45			
N-15	SJ15N1	M20×55	QJR07	SJ06B1	M10×30
N-18	SJ15N1	M20×55	QJR08	SJ08B1	M12×35
N-21	SJ18A2	M20×60	QJR10	SJ10B1	M12×35
N-24	SJ18A2	M20×60	QJR12	SJ12N1	M16×45

■ 高爪適用表

Interchangeable High jaws with standard jaws

標準爪型式 Standard jaw	高爪型式 High jaw
SJ04B1	SJ04A1-036 SJ04A1-048
SJ04A1T★	SB04A1T036★ SJ04A1T048★
SJ04N1	SJ04N1-036 SJ04N1-048
SJ04N1T★	SJ04N1T036★ SJ04N1-048
SJ05B1	SJ05A1-038 SJ05A1-053
SJ05A1T★	SJ05A1T038★ SJ05A1T053★
SJ05N1	SJ05N1-038 SJ05N1-053
SJ05N1T★	SJ05N1-038 SJ05N1T-53★
SJ06B1	SJ06A1-066
SJ06A1T★	SJ06A1T066★
SJ06D1	SJ06D1-066
SJ06L1A	SJ06A1-066
SJ06L1T★	SJ06A1T066★
SJ08B1	SJ08A1-056 SJ08A1-076
SJ08B1Q	SJ08B1Q-76
SJ08A1	SJ08A1-056 SJ08A1-076 SJ08A1T056★ SJ08A1T076★
SJ10A1	SJ10A1-056 SJ10A1-080 SJ10A1-116 SJ10A1T080★
SJ10B1	SJ10A1-056 SJ10A1-080 SJ10A1-116
SJ10A2Q	SJ10A2Q080
SJ12A1	SJ12A1-090 SJ12A1T090★
SJ12N1	SJ12N1-090
SJ15C1	SJ15C1-110
SJ15N1	SJ15N1-110
SJ18A2	SJ18A2-110
SB06BB	SB06BB-040
SB08BB	SB08BB-056
SB10BB	SB10BB-060
SB12BB	SB12BB-070

※★マークのついている型式は、2ヶ/1セットです。
 その他は、3ヶ/1セットでの販売となります。

※Models with the ★ mark are 2 pieces / set.
 Others are 3 pieces / set.

■ BR専用 小径把握用ソフトジョー

BR soft jaw for small diameter gripping

チャック型式 Chuck	ソフトジョー型式 Soft jaw	取付ボルト Mounting bolt	外形把握での把握範囲 Gripping range at gripping the outer diameter
BR06	SJ06S1	M10×25	φ8~170
BR08	SJ08S1	M12×30	φ12~210
BR10	SJ10S1	M12×30	φ20~254
BR12	SJ12S1	M16×35	φ34~315
BRT06	SJ06S1	M10×25	φ14~170
BRT08	SJ08S1	M12×30	φ16~210
BRT10	SJ10S1	M12×30	φ29~254
BRT12	SJ12S1	M16×35	φ41~315

※ここに記載のソフトジョーは全て3ヶ/セットです。

※All soft jaws listed here come in sets of 3.

参考図1 Ref. DWG. 1

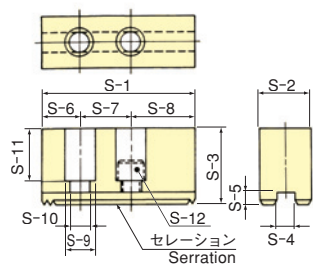

参考図2 Ref. DWG. 2

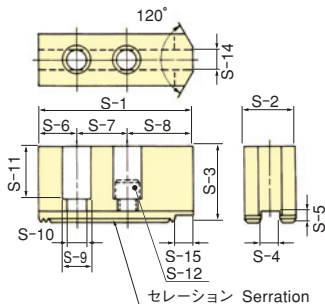

参考図3 Ref. DWG. 3

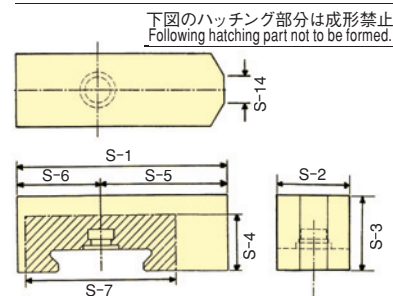

■ ソフトジョー寸法表 Dimensions

ソフトジョー型式 Soft Jaw TYPE	S-1	S-2	S-3	S-4	S-5	S-6	S-7	S-8	S-9	S-10	S-11	S-12	S-14	S-15	セレーションピッチ Serration pitch	参考図 Ref. DWG.
SJ04B1	55	23	25	10	4	13	14	28	13.5	8.5	16	M8	3	13	1.5×60°	2
SJ04A1-036	55	23	36	10	4	13	14	28	13.5	8.5	27	M8			1.5×60°	1
SJ04A1-048	55	23	48	10	4	13	14	28	13.5	8.5	39	M8			1.5×60°	1
SJ04A1T	55	23	25	10	4	13	14	28	13.5	8.5	16	M8			1.5×60°	1
SB04A1T036	55	23	36	10	4	13	14	28	13.5	8.5	27	M8			1.5×60°	1
SJ04A1T048	55	23	48	10	4	13	14	28	13.5	8.5	39	M8			1.5×60°	1
SJ04N1	49.5	23	23	10	4	10	14	25.5	13.5	8.5	14.5	M8	4		1.5×60°	2
SJ04N1-036	49.5	23	36	10	4	10	14	25.5	13.5	8.5	27.5	M8			1.5×60°	1
SJ04N1-048	49.5	23	48	10	4	10	14	25.5	13.5	8.5	39.5	M8			1.5×60°	1
SJ04N1T	49.5	23	23	10	4	10	14	25.5	13.5	8.5	14.5	M8			1.5×60°	1
SJ04N1T036	49.5	23	36	10	4	10	14	25.5	13.5	8.5	27.5	M8			1.5×60°	1
SJ05B1	62	23	27	10	4	14	19	29	13.5	8.5	18	M8	12	14	1.5×60°	2
SJ05A1-038	62	23	38	10	4	14	19	29	13.5	8.5	29	M8			1.5×60°	1
SJ05A1-053	62	23	53	10	4	14	19	29	13.5	8.5	44	M8			1.5×60°	1
SJ05A1T	62	23	27	10	4	14	19	29	13.5	8.5	18	M8			1.5×60°	1
SJ05A1T038	62	23	38	10	4	14	19	29	13.5	8.5	29	M8			1.5×60°	1
SJ05A1T053	62	23	53	10	4	14	19	29	13.5	8.5	44	M8			1.5×60°	1
SJ05N1	54	23	25	10	4	12	14	28	13.5	8.5	16.5	M8	5		1.5×60°	2
SJ05N1-038	54	23	38	10	4	12	14	28	13.5	8.5	29.5	M8			1.5×60°	1
SJ05N1-053	54	23	53	10	4	12	14	28	13.5	8.5	44.5	M8			1.5×60°	1
SJ05N1T	54	23	25	10	4	12	14	28	13.5	8.5	16.5	M8			1.5×60°	1
SJ05N1T-53	54	23	53	10	4	12	14	28	13.5	8.5	44.5	M8			1.5×60°	1
SJ06B1	72	31	32	12	5	15	20	37	17	11	20	M10	12	15	1.5×60°	2
SJ06S1	75.5	31	32	12	5	15	20	40.5	17	11	20	M10	5	29.5	1.5×60°	2
SJ06A1-066	72	31	66	12	5	15	20	37	17	11	54	M10			1.5×60°	1
SJ06A1T	72	31	32	12	5	15	20	37	17	11	20	M10			1.5×60°	1
SJ06A1T066	72	31	66	12	5	15	20	37	17	11	54	M10			1.5×60°	1
SJ06C1	76.5	40	37	14	5	15	25	36.5	19	13	22	M12			1.5×60°	1
SJ06D1	72	31	32	12	5	22	20	30	17	11	20	M10	6	15	1.5×60°	2
SJ06D1-066	72	31	66	12	5	22	20	30	17	11	54	M10	6	15	1.5×60°	2
SJ06L1A	66	26	28	12	5	12	20	34	17	11	16	M10	5	12	1.5×60°	2
SJ06L1T	66	26	28	12	5	12	20	34	17	11	16	M10			1.5×60°	1
SJ08A1	95	35	42	14	5	24	25	46	19	13	27	M12			1.5×60°	1
SJ08B1	95	35	38	14	5	24	25	46	19	13	23	M12	12	20	1.5×60°	2
SJ08S1	95	35	38	14	5	19.5	25	50.5	19	13	23	M12	9	20	1.5×60°	2
SJ08A1-056	95	35	56	14	5	24	25	46	19	13	41	M12			1.5×60°	1
SJ08A1-076	95	35	76	14	5	24	25	46	19	13	61	M12			1.5×60°	1
SJ08B1Q	90	31	38	12	5	24	20	46	17	11	26	M10	16	24	1.5×60°	2
SJ08B1Q-76	90	31	76	12	5	24	20	46	17	11	64	M10	16	24	1.5×60°	2
SJ08A1T056	95	35	56	14	5	24	25	46	19	13	41	M12			1.5×60°	1
SJ08A1T076	95	35	76	14	5	24	25	46	19	13	61	M12			1.5×60°	1
UB450	165	62	66	25.5	8	37	43	85	32	21	43	M20			3.0×60°	1
UB560K	180	65	69.2	25.5	8	39.5	60	80.5	32	21	45.3	M20			3.0×60°	1
UB710	209.5	75	80	30	9	40	60	109.5	39	26	55	M24			3.0×60°	1

参考図4 Ref. DWG. 4

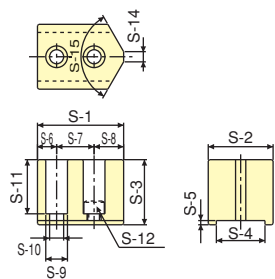

参考図1、2 セレーション部詳細
Ref. DWG. 1, 2 Serration

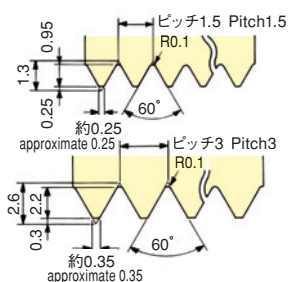

■ ソフトジョー寸法表 Dimensions

ソフトジョー型式 Soft Jaw TYPE	S-1	S-2	S-3	S-4	S-5	S-6	S-7	S-8	S-9	S-10	S-11	S-12	S-14	S-15	セレーションピッチ Serration pitch	参考図 Ref. DWG.
SJ10B1	110	40	42	16	5	30	30	50	19	13	27	M12	15	20	1.5×60°	2
SJ10A1	110	40	42	16	5	30	30	50	19	13	27	M12			1.5×60°	1
SJ10S1	110	40	42	16	5	25.5	30	54.5	19	13	27	M12	15	20	1.5×60°	2
SJ10A1-056	110	40	56	16	5	30	30	50	19	13	41	M12			1.5×60°	1
SJ10A1-080	110	40	80	16	5	30	30	50	19	13	65	M12			1.5×60°	1
SJ10A1-116	110	40	116	16	5	30	30	50	19	13	101	M12			1.5×60°	1
SJ10A2Q	110	40	42	16	6	30	30	50	19	13	26	M12			3.0×60°	1
SJ10A2Q080	110	40	80	16	6	30	30	50	19	13	64	M12			3.0×60°	1
SJ10A1T080	110	40	80	16	5	30	30	50	19	13	65	M12			1.5×60°	1
SJ10D1	101.5	45	45	18	5	22.5	30	49	22	15	25	M14	15	17.5	1.5X60°	2
SJ12A1	129	50	50	18	5	39	30	60	22	15	30	M14			1.5×60°	1
SJ12S1	114	50	50	21	4	19.5	30	64.5	25	17	33	M16			1.5×60°	1
SJ12A1-090	129	50	90	18	5	39	30	60	22	15	70	M14			1.5×60°	1
SJ12C1	129	50	50	18	5	32	38	59	22	15	35	M14			1.5×60°	1
SJ12A1T090	129	50	90	18	5	39	30	60	22	15	70	M14			1.5×60°	1
SJ12N1	111	50	50	21	4	21	30	60	25	17	33	M16			1.5×60°	1
SJ12N1-090	111	50	90	21	4	21	30	60	25	17	73	M16			1.5×60°	1
SJ15C1	165	62	66	22	8	37	43	85	32	21	42	M20			1.5×60°	1
SJ15C1-110	165	62	110	22	8	37	43	85	32	21	86	M20			1.5×60°	1
SJ15A2	156	62	70	22	9	36	60	60	32	21	45	M20			3.0×60°	1
SJ15A2Q	129	50	50	18	6	32	38	59	22	15	34	M14			3.0×60°	1
SJ15C1T	165	62	66	22	8	37	43	85	32	21	42	M20			1.5×60°	1
SJ15N1	135	50	60	25.5	5	26	43	66	32	21	39	M20			1.5×60°	1
SJ15N1-110	135	50	110	25.5	5	26	43	66	32	21	89	M20			1.5×60°	1
UVE500AR	210	65	100	25	9	40	60	110	32	21	75	M20			3.0×60°	1
SJ18A2	180	65	70	25	9	40	60	80	32	21	45	M20			3.0×60°	1
SJ18A2-110	180	65	110	25	9	40	60	80	32	21	85	M20			3.0×60°	1
SB06BB	90	32	30	24	54	36	68						5			3
SB06BB-040	90	32	40	24	54	36	68						5			3
SB08BB	106	37	38	28	64	42	76						14			3
SB08BB-056	106	37	56	28	64	42	76						14			3
SB10BB	125	42	42	31	76	49	88						26			3
SB10BB-060	125	42	60	31	76	49	88						26			3
SB12BB	139	42	50	34	90	49	92						30			3
SB12BB-070	139	42	70	34	90	49	92						30			3
PW-06	67.5	50.8	51	38.07	3.3	15	29.36	23.14	17	11	42.4	M10	8	120°		4
PW-08	74	57	57.47	44.45	3.3	15	34.14	24.86	20	13.5	47	M12	41	90°		4
PW-10	89.5	70.1	70.2	57.1	3.3	19	44.45	26.05	25	17	59	M16				4
PW-12	108.5	70.1	70.2	57.1	3.3	19	44.45	45.05	25	17	59	M16				4
PW-15	140	76.2	76.5	66.62	3.3	23.9	53.98	62.12	32	21	61.2	M20				4



CHUCK

パワーチャック用ハードジョー Hard Jaws for Power Chuck HB series

型式表示 Description of Model

HB06B1

- セレーションピッチを表す。Serration pitch
1=1.5mm×60°、2=3mm×60°、3=1/16"×90°、4=3/32"×90°
- 形状、特徴を表す。Form and characteristic
- チャックサイズを表す。Chuck sizes
- パワーチャックハードジョーを表す。Power chuck hard jaw

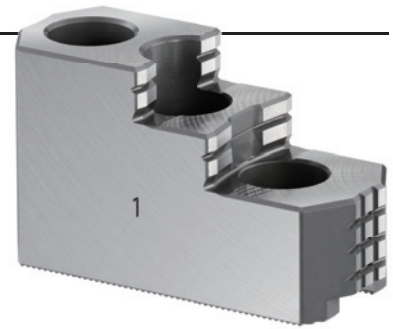

■ ハードジョー兼用表 Combination of Hard Jaws

ジョー型式 Hard Jaw TYPE	適応中実チャック型式 Adaptive closed centre chuck	適応中空チャック型式 Adaptive open centre chuck
HB04N1	N-04	BR05, B-204, B-205
HB05C1	N-05	
HB06A1	N-06, NLO6	BR06, BB206, BS306, B-206, HOH-206, BL206
HB06B1	N-06, NLO6	BR06, BB206, BS306, B-206, HOH-206, BL206
HB08A1	N-08, NLO8	B-208, HOH-208, BL208
HB08B1		BR08, BB208, BS308
HB08N1		BR08, BB208
HB10A1	N-10, NL10	B-210, HOH-10K, BL210
HB10AA1		BR10, BB210, BS310
HB12B1	N-12, NL12	HOH-12K
HB12N1		BR12, BB212, B-212, BL212
HB15A1		HOH-15K, B-15, B-18
HB15N1	N-15, N-18, NV15, NV18	B-215
HB18B2	N-21, N-24, NV21, NV24, NV28, NV32, NV36, NV40	B-21, B-24
HB24B2		
HB06U1		UVE160K
HB08U1		UVE200K, UVE250K
HB12U1		UVE315K
HB16U2		UVE400K
HB18W2		UB450K

参考図1 Ref. DWG. 1

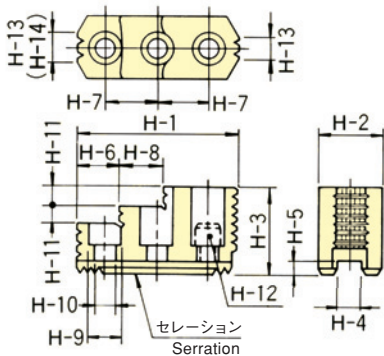

参考図2 Ref. DWG. 2

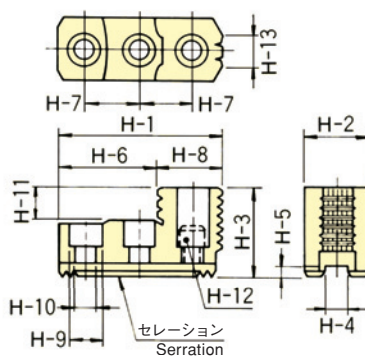

参考図3 Ref. DWG. 3

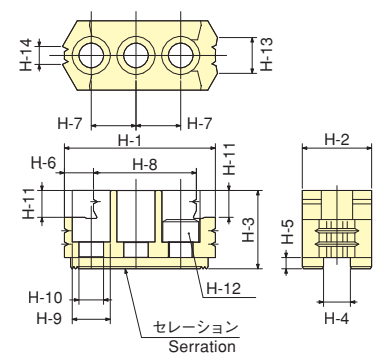

■ ハードジョー寸法表 Dimensions

ジョー型式 Hard Jaw TYPE	H-1	H-2	H-3	H-4	H-5	H-6	H-7	H-8	H-9	H-10	H-11	H-12	H-13	H-14	セレーションピッチ Serration pitch	参考図 Ref. DWG.
HB04N1	53	23	27.5	10	4	30.5	14	22.5	13.5	8.5	10	M 8	6	—	1.5	2
HB05C1	61	23	30	10	4	7.5	19	53.5	13.5	8.5	12	M 8	6	—	1.5	2
HB06A1	66.6	31	36	12	5	40	20	26.6	17	11	12	M10	10	—	1.5	2
HB06B1	67.5	31	35	12	5	13	20	46	17	11	12	M10	16	10	1.5	3
HB08A1	86	35	51	14	5	31	25	18	19	13	12	M12	12	12	1.5	1
HB08B1	92	35	51	14	5	12	25	63	19	13	18	M12	11	11	1.5	3
HB08N1	88	35	51	14	5	36	25	14	19	13	12	M12	12	11	1.5	1
HB10A1	99.5	40	54	16	5	43	30	17	19	13	13	M12	15	15	1.5	1
HB10AA1	102.5	40	54	16	5	43	30	17	19	13	13	M12	15	15	1.5	1
HB12B1	97.5	50	55	18	5	64.5	30	33	22	15	20	M14	30	—	1.5	2
HB12N1	103	50	52	21	4	62.5	30	40.5	25	17	17	M16	30	—	1.5	2
HB15A1	149	62	86	22	8	63	43	34	32	21	20	M20	40	40	1.5	1
HB15N1	149	62	86	25.5	5	69	43	27	32	21	20	M20	43	38	1.5	1
HB18B2	159.5	80	90	25	9	104.5	50	55	32	21	40	M20	55	—	3.0	2
HB24B2	183.5	90	105	25	9	116.5	60	67	32	21	50	M20	76	—	3.0	2
HB06U1	69.5	35	48	14	5	34	19	18	19	13	12	M12	12	20	1.5	1
HB08U1	79.25	40	42	16	5	35.25	21	44	19	13	14	M12	12	—	1.5	2
HB12U1	107.25	45	50	18	5	56.75	30	50.5	22	15	20	M14	25	—	1.5	2
HB16U2	138.5	60	71	22	9	76.5	43	62	32	21	26	M20	35	—	3.0	2
HB18W2	155.5	60	85	25.5	9	79.5	43	24	32	21	20	M20	38	—	3.0	1

※HB06A1の爪形状は2段です。※The form of HB06A1 is 2-step jaw.



Tナット T-nut

参考図1 Ref. DWG. 1

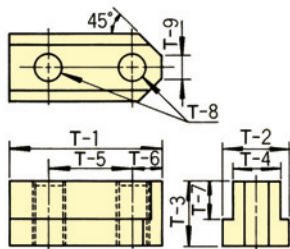

※T-8はソフトジョー取付ボルトサイズです。
※T-8 is the size of soft jaw mounting bolt.

参考図2 Ref. DWG. 2

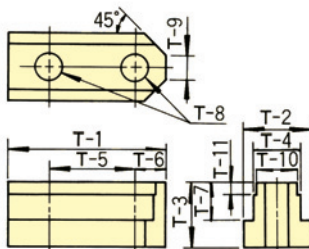

※T-8はソフトジョー取付ボルトサイズです。
※T-8 is the size of soft jaw mounting bolt.

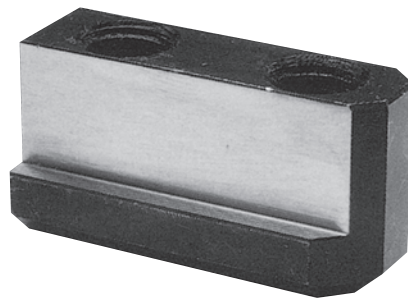

参考図3 Ref. DWG. 3

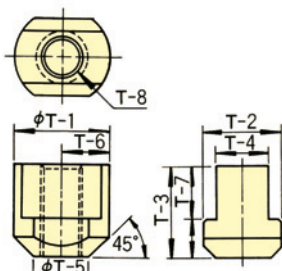

※T-8はソフトジョー取付ボルトサイズです。
※T-8 is the size of soft jaw mounting bolt.

参考図4 Ref. DWG. 4

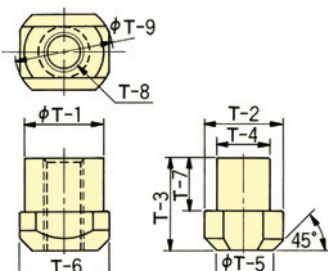

※T-8はソフトジョー取付ボルトサイズです。
※T-8 is the size of soft jaw mounting bolt.

参考図5 Ref. DWG. 5

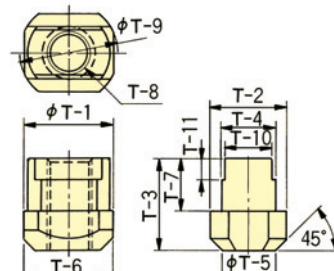

※T-8はソフトジョー取付ボルトサイズです。
※T-8 is the size of soft jaw mounting bolt.

※ご注文に際しては、チャック型式及びTナット寸法をご指示の上ご注文下さい。

※Please inform us of the chuck type and T-Nut dimensions before ordering.

■ Tナット適応表、寸法表 Dimensions and Combination

T-1	T-2	T-3	T-4	T-5	T-6	T-7	T-8	T-9	T-10	T-11	適応チャック型式 Adaptive chuck	参考図 Ref. DWG.
26	14.5	15	10	14	6	9.5	M8	5	-	-	BR05, B-204, BT204, B-205, BT205	1
26	14.5	18	10	14	6	12.5	M8	5	-	-	N-04, NT04, NL04, AS04, AT04, NRC04	1
32	14.5	18	10	19	6	12.5	M8	6	-	-	N-05, NT05	1
36.5	17	18.5	12	20	8.25	11	M10	8	-	-	HW-08, HRS08	1
36.5	17	22.5	12	20	7.5	15	M10	8	-	-	N-06, NL06, NLT06, AS06, AT06, NRC06	1
46.5	20	20.5	14	25	10.5	12	M12	12	-	-	BR08, B-208, BB208, BS308, BAT08, BT208, BBT208, HOH-208, BL208, BLT208	1
48	20	25.5	14	25	11	16	M12	8	-	-	N-08, NL08, NLT08, AS08, AT08, NRC08	1
51	22	21.5	16	30	11	13	M12	11	-	-	BR10, B-210, BB210, BS310, BRT10, BT210, BBT210, BL210, BLT210	1
55	22	25.5	16	30	11	16	M12	8	-	-	N-10, NL10, NLT10, AS10, AT10, NRC10, HW-10, HW-12	1
56.25	29.5	22.75	21	30	12	11.25	M16	9.5	-	-	BR12, BB212, BRT12, BBT212	1
55.5	29.5	27.75	21	30	12	16.25	M16	13	-	-	B-212, BT212, BL212, BLT212	1
55.5	26.5	31	18	30	11.5	17.5	M14	12	-	-	HOH-12K	1
55.5	26.5	33.5	18	30	11.5	20	M14	12	-	-	N-12, NL12, NLT12	1
62.5	26.5	33.5	18	38	12	20	M14	12	-	-	HW-15	1
91	32	18	22.2	53.98	15.02	10.5	M20	-	-	-	PW-15, PW-21	1
90	37.5	45	25	50	20	26	M20	16	-	-	B-21・24, ハードジョー用 For hard jaw	1
100	37.5	45	25	60	20	26	M20	16	-	-	B-21・24, ソフトジョー用 For soft jaw	1
80	33.5	40.5	24	43	17	24	M20	11	22	7.5	HOH-15K	2
80	33.5	45.5	24	43	17	29	M20	11	22	8.2	B-15, BT15, B-18	2
80	35	39.25	25.5	43	17	20.25	M20	14	-	-	B-215	1
42	35	39.25	25.5	25	-	20.25	M20	-	-	-	N-15, N-18, NV15, NV18	3
46	37.5	45	25	26.5	-	26	M20	-	-	-	N-21, N-24, NV21, NV24, NV28, NV32, NV36, NV40	3
19	22.5	23.5	14	19.5	19	15	M12	24.5	-	-	UVE160K	4
19	22.5	24	16	19.5	19	15.5	M12	24.5	-	-	UVE200K, UVE250K	4
24	28.5	27.5	18	24	24	17	M14	32	-	-	UVE315K	4
32	36	30.5	24	30	32	20	M20	40	22	8.5	UVE400K	5
46	19.8	10.7	12.65	29.36	8.5	6	M10	-	-	-	PW-06	1
53.2	21.6	12.9	14.24	34.14	9.5	7.4	M12	-	-	-	PW-08	1
68.45	27.4	17	19	44.5	12	10	M16	-	-	-	PW-10, PW-12	1
32	36	29.5	25.5	32	32	19	M20	42	-	-	UB450K, UB560K	4
-	44	44	30	32	36	26	M24	52	-	-	UB630K, UB710K	4

Tナット-PlusについてはP.9をご参照ください。

Please refer to page 9 for Tnut-Plus.



CHUCK

スクロールチャック用ハードジョー Hard Jaws for Scroll Chuck HBS series

型式表示 Description of Model

HBS06C

- 使用チャック型式を表す。Chuck type
C=JN
- チャックサイズを表す。Chuck sizes
スクロールチャックハードジョーを表す。
Hard jaw of scroll chuck



■ ハードジョー兼用表 Combination Table for Hard Jaws

ハードジョー型式 Hard jaw type	適応チャック型式 Adaptive chuck model
HBS06C	JN06T, JN06RA5
HBS07C	JN07T, JN07RA5, JN08RA6
HBS09C	JN09T, JN09RA6
HBS10C	JN10T, JN10RA6 (8)
HBS12C	JN12T, JN12RA6 (8)

■ 寸法図 Dimensional Drawings

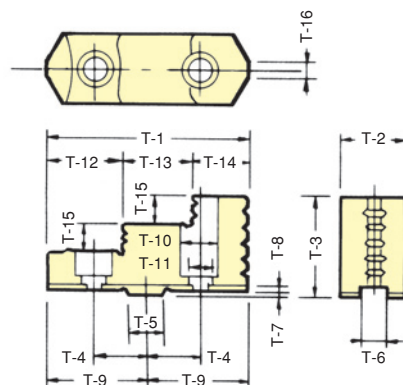
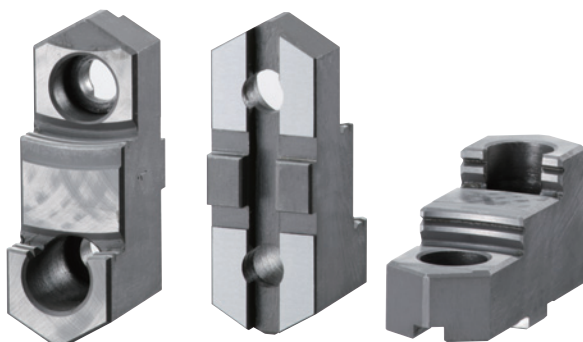

■ 寸法表 Dimensions

型式 TYPE	チャックサイズ Chuck size	T-1	T-2	T-3	T-4	T-5	T-6	T-7	T-8	T-9	T-10	T-11	T-12	T-13	T-14	T-15	T-16	取付ボルト Mounting bolt
HBS06C	6	68	26	37	19.05 ^{±0.1}	12.68 ^{+0.008 -0.003}	7.94 ^{+0.05 0}	3	3.5	34	14	8.5	26	21.5	20.5	8.5	2	M 8 × 20
HBS07C	7	80	28	40	22.225 ^{±0.1}	12.68 ^{+0.008 -0.003}	7.94 ^{+0.05 0}	3	3.5	40	17	11	30.5	26	23.5	9.5	2	M10 × 20
HBS09C	9	90	32	48	26.99 ^{±0.1}	19.03 ^{+0.009 -0.004}	12.7 ^{+0.05 0}	3	3.5	45	19	13	34	30	26	12	3	M12 × 25
HBS10C	10	100	35	52	26.99 ^{±0.1}	19.03 ^{+0.009 -0.004}	12.7 ^{+0.05 0}	3	3.5	50	19	13	38	32	30	14	3	M12 × 25
HBS12C	12	115	40	54	31.75 ^{±0.1}	19.03 ^{+0.009 -0.004}	12.7 ^{+0.05 0}	3	3.5	57.5	19	13	46	35	34	15	4	M12 × 25



CHUCK

スクロールチャック用ソフトジョー Soft Jaws for Scroll Chuck SBS series

型式表示 Description of Model

SBS06

チャックサイズを表す。Chuck sizes
スクロールチャックソフトジョーを表す。
Soft jaw of scroll chuck



■ソフトジョー兼用表 Combination Table for Soft Jaws

ソフトジョー型式 Soft jaw type	適応チャック型式 Adaptive chuck model
SBS03	SC-3F
SBS04	SC-4F
SBS05	SC-5F
SBS06	JN06T, JN06RA5
SBS07	JN07T, JN07RA5, JN08RA6, JT07
SBS09	JN09T, JN09RA6, JT09
SBS10	JN10T, JN10RA6(8)
SBS12	JN12T, JN12RA6(8)

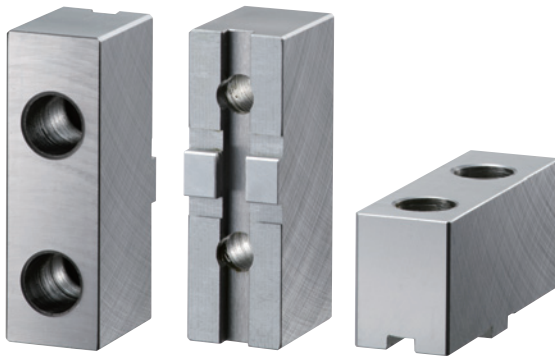

■寸法図 Dimensional Drawings

SBS03, SBS04, SBS05

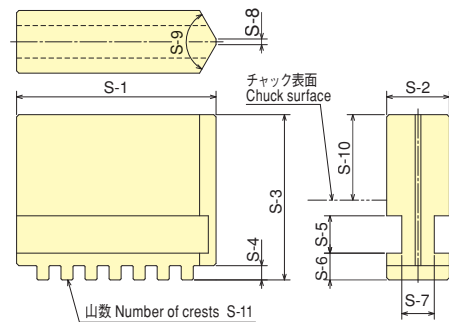

SBS06, SBS07, SBS09, SBS10, SBS12

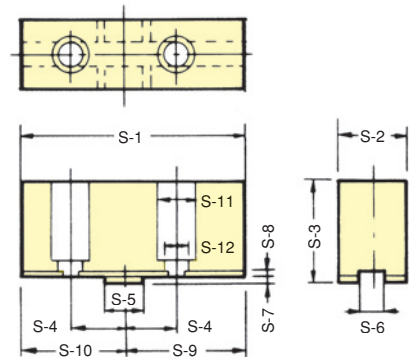

■寸法表 Dimensions

型式 TYPE	チャックサイズ Chuck size	S-1	S-2	S-3	S-4	S-5	S-6	S-7	S-8	S-9	S-10	S-11	S-12	取付ボルト Mounting bolt
SBS03	3	35	11	29	2.5	6.55	4.7	5.7	1	120°	15	7		
SBS04	4	42	14	34.5	3.5	6.55	6.2	7.2	1.5	120°	18	7		
SBS05	5	50	16	40	4	8.2	7.7	7.2	1.5	120°	20	7		
SBS06	6	75	26	38	19.05 \pm 0.1	12.68 $\begin{smallmatrix} +0.008 \\ -0.003 \end{smallmatrix}$	7.94 $\begin{smallmatrix} +0.05 \\ 0 \end{smallmatrix}$	3	3.5	41	34	14	8.5	M 8 × 20
SBS07	7	88	28	41	22.225 \pm 0.1	12.68 $\begin{smallmatrix} +0.008 \\ -0.003 \end{smallmatrix}$	7.94 $\begin{smallmatrix} +0.05 \\ 0 \end{smallmatrix}$	3	3.5	48	40	17	11	M10 × 20
SBS09	9	100	32	48	26.99 \pm 0.1	19.03 $\begin{smallmatrix} +0.009 \\ -0.004 \end{smallmatrix}$	12.7 $\begin{smallmatrix} +0.05 \\ 0 \end{smallmatrix}$	3	3.5	55	45	19	13	M12 × 25
SBS10	10	110	35	52	26.99 \pm 0.1	19.03 $\begin{smallmatrix} +0.009 \\ -0.004 \end{smallmatrix}$	12.7 $\begin{smallmatrix} +0.05 \\ 0 \end{smallmatrix}$	3	3.5	60	50	19	13	M12 × 25
SBS12	12	125	40	54	31.75 \pm 0.1	19.03 $\begin{smallmatrix} +0.009 \\ -0.004 \end{smallmatrix}$	12.7 $\begin{smallmatrix} +0.05 \\ 0 \end{smallmatrix}$	3	3.5	67.5	57.5	19	13	M12 × 25



CHUCK

バックプレート Back Plate

■ バックプレート適合表 Back Plate Acceptable table

型式 Model	チャックサイズ Chuck Size	主軸端形状 Spindle Nose				
		A2-5	A2-6	A2-8	A2-11	A2-15 (IEJIS) (Former JIS)
BR BB200	6	CBB-06A05	CBB-06A06			
	8	CBB-08A05	61P363755	CBB-08A08		
	10		CB-10A06	CB-10A08		
	12		61P393994	CB-15A08	61Q349363	
B-200 QB300	6	CB-06A05	CB-06A06			
	8	CB-08A05	CB-08A06	CB-08A08		
	10		CB-10A06	CB-10A08	CB-10A11	
	12			CB-10A08	CB-10A11	
	15		61P393994	CB-15A08	CB-15A11	CB-15A15
B	15		61P393994	CB-15A08	CB-15A11	CB-15A15
	18			CB-18A08	CB-18A11	CN-21A15
	21				CB-21A11	CB-21A15
	24				CB-21A11	CB-21A15
BS300	6	61P363754				
	8	61P371952	61P363755			
	10		61P363757	61P363756		
BL200	6	CB-06A05	CB-06A06			
	8		CB-08A06	CB-08A08		
	10		CB-10A06	CB-10A08	CB-10A11	
	12		CB-10A06	CB-10A08	CB-10A11	
QJR	7	CB-06A05	CB-06A06			
	8	CB-08A05	CB-08A06	CB-08A08		
	10		CB-10A06	CB-10A08	CB-10A11	
	12			CB-10A08	CB-10A11	
BRT	6	CBBT06A05				
	8	CBBT08A05	CBBT08A06			
	10		CBT10A06	CBT10A08		
	12			CBT15A08	61P836116	
BT200	6	CBT06A05	CBT06A06			
	8	CBT08A05	CBT08A06	CBT08A08		
	10		CBT10A06	CBT10A08	CBT10A11	
	12		CBT10A06	CBT10A08	CBT10A11	
BLT200	6	CBT06A05	CBT06A06			
	8		CBT08A06	CBT08A08		
	10		CBT10A06	CBT10A08	CBT10A11	
	12			CBT10A08	CBT10A11	
BBT200	6	CBBT06A05				
	8	CBBT08A05	CBBT08A06			
	10		CBT10A06	CBT10A08		
	12			CBT15A08	61P836116	
N	6	CB-06A05	CB-06A06			
	8	CB-08A05	CB-08A06	61Q327856		
	10		CN-10A06	CB-10A08	CB-10A11	
	12		CN-10A06	CB-10A08	CB-10A11	
	15			CN-15A08	CB-15A11	
	18			CN-15A08	CB-15A11	CB-21A15
	21			CN-21A08	CN-21A11	CB-21A15
	24				CN-21A11	
NL	6	CB-06A05	CB-06A06			
	8		CB-08A06	CB-08A08		
	10		CN-10A06	CB-10A08		
	12		CN-10A06	CB-10A08	CB-10A11	
	18			CN-15A08	CB-15A11	
ML	6	CB-06A05	CB-06A06			
8	CB-08A05	CB-08A06	CB-08A08			
NT	15			CBT15A08	CBT15A11	
NLT	6	CBT06A05	CBT06A06			
	8		CBT08A06	CBT08A08		
	10		CNT10A06	CBT10A08	CBT10A11	
	12		CNT10A06	CBT10A08	CBT10A11	
MLT	6	CBT06A05	CBT06A06			
MLV	8	CBT08A05	CBT08A06	CBT08A08		
HW	8	61P342469	61Q341375	61Q382381		
	10		61Q330007	61P344050		
	12		61Q330007	61P344050		
	15			61Q379169	61Q308602	

**CHUCK**

カバーフタ Cover Cap

■ 寸法図 Dimensional Drawings

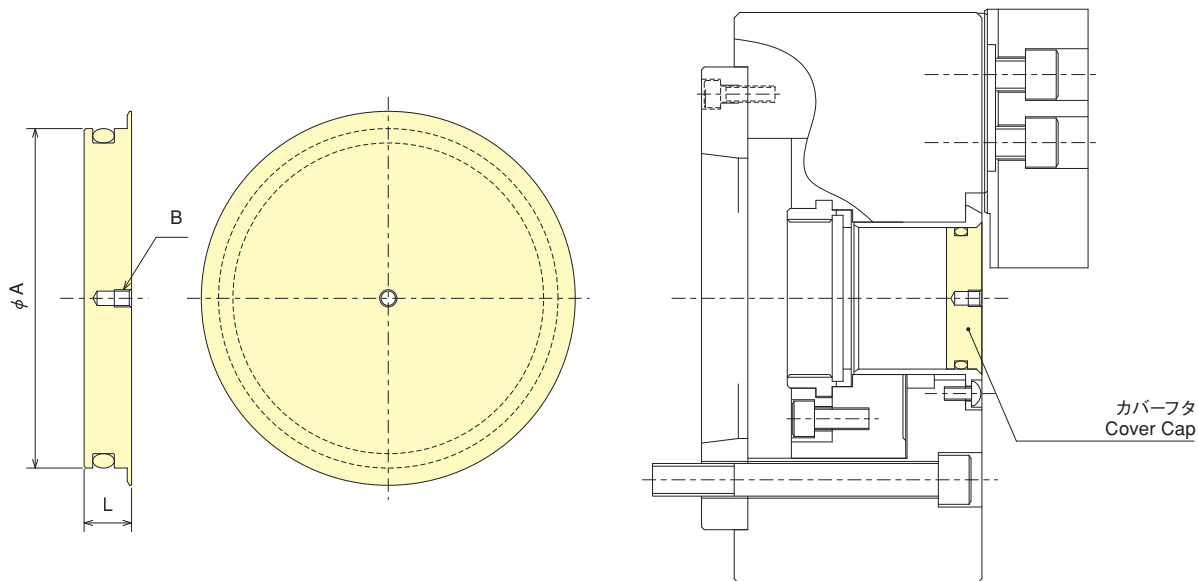

■ 寸法表 Dimensions

チャック型式 Chuck Model	寸法 Dimension			Oリング O-ring
	A	L	B	
BR05/B-205/BT205	33	12	M5	P26
BR06/BRT06/BB206/BBT206	53	13	M6	P46
BR08/BRT08/BB208/BBT208	66	15	M6	P56
BR10/BRT10/BB210/BBT210	81	15	M6	P71
BR12/BRT12/BB212/BBT212	106	15	M6	P95
B-15/B-18	117.5	16.5	—	P105
B-21	140	15	M6	P130
B-24	165	15	M6	G155
B-204/BT204	26	9	M5	P22
B-206/BT206	45	13	M6	P38
B-206	46	13	M6	P40
DLR08/B-208/BT208	52	13	M6	P46
B-208	53	13	M6	P46
B-210/BT210	75	15	M6	P65
B-210	77	15	M6	P67
B-210	78	15	M6	P67
B-212/BT212	91	15	M6	P80
B-215	100	17	M6	P90
BL206/BLT206	28	12	M5	P22A
BL208/BLT208	45	13	M6	P38
BL210/BLT210	53	13	M6	P46
BL212/BLT212	63	15	M6	P53
BS306	45	13	M6	P38
BS308	52	13	M6	P46
BS310	75	15	M6	P65

チャック型式によりサイズの異なるものが存在します。
ご注文の際にはA寸法をご確認の上、ご注文をお願いします。

The size may vary as per Chuck models. Check "A" dimension when the order is placed.



CHUCK

チャックグリース

Chuck Grease Pro

チャック把握力が1.5倍に (一般グリース比)
寿命は約3倍に (一般グリース比)

●人の健康や生態系への配慮

「PRTTR法」(特定化学物質の環境への排出量の把握等及び管理の改善の促進に関する法律)に該当しない。

●把握力の低下率が小さい

B-206チャックにおける当社比(図2参照)。

●黒色グリースから白色グリースへ進化

黒色の「汚れる」「汚い」といったイメージから脱却。

●多様な商品形態をご用意

18kgペール缶、1kg缶、400gジャバラ、400gカートリッジの4タイプ。

CHUCK GREASE PROは、KITAGAWAの豊富な経験と実績に基づき、チャック専用グリースとして厳選した特殊グリースです。

良好な潤滑性は、チャックの把握力維持、精度維持等チャック性能を最大限に発揮します。また、安全性を向上し、寿命も延長します。

●安全データシート(SDS)

以下のサイトでダウンロードできます。

<https://prod.kiw.co.jp/mtools/others/2259.html>



図1 グリースによる把握力比較



図2 グリースによる把握力低下の比較



※グリースの性能を提示するためのグラフであり、チャックの使用条件を保証するものではありません。
チャックの使用条件は、チャックの仕様表をご参照下さい。

■使用方法

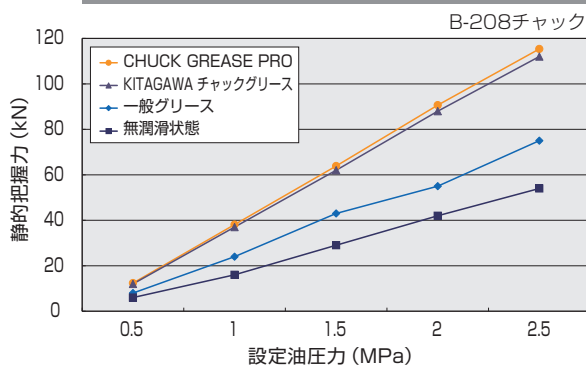
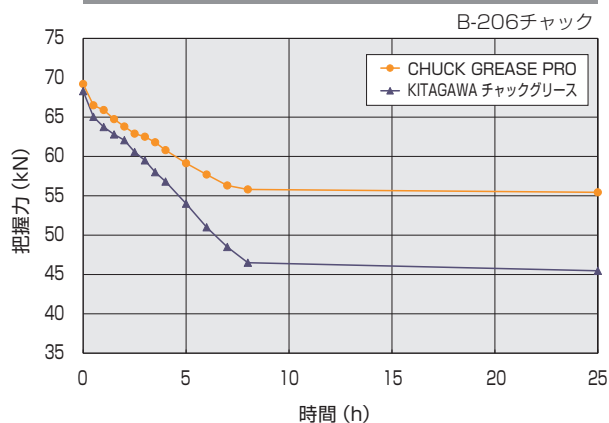
一般のグリースと同様、チャックの取扱説明書をご参考に、市販のグリースガンで給油して下さい。

■代表特性

色	淡黄色～黄色ペースト状
密度 g/cm ³	1.12
使用温度範囲 °F (°C)	18～300 (-28～149)
摩擦係数	0.06～0.1 (LFW-1 回転往復試験機による)
NLGI稠度	#2
JIS K-2220に準ずる稠度	混和 60回 265-295



CHUCK

Chuck Grease

Chuck Grease Pro

**Chuck Gripping Force 1.5 times
(Compared to Standard Grease)**

**Service Life 3 times
(Compared to Standard Grease)**

- Conforms to international standards for health, safety and the environment
- Loss of grip over time is reduced
Refer to graph below for B206 chuck.
- White grease is cleaner and reduces contamination
- Various sizes available; 18kg can, 1kg can, 400g bellows and 400g cartridge

Chuck Grease Pro has been specially developed by Kitagawa by utilising long term experience in many applications. The use of Chuck Grease Pro will extend life, increase gripping force and improve safety.

● **Safety Data Sheet (SDS)**

can be downloaded from the following URL:
https://www.kitagawa.com/en/mttools/others/chuck_grease_pro.html



Fig.1 Gripping force check by grease

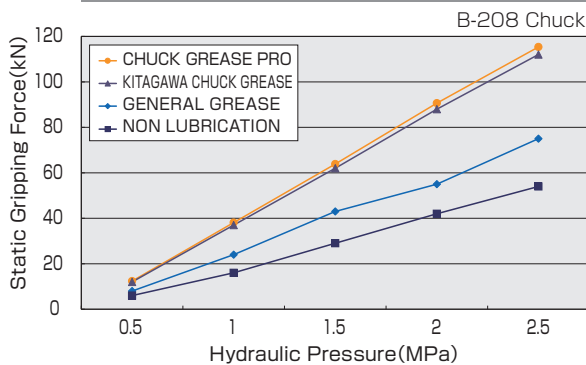
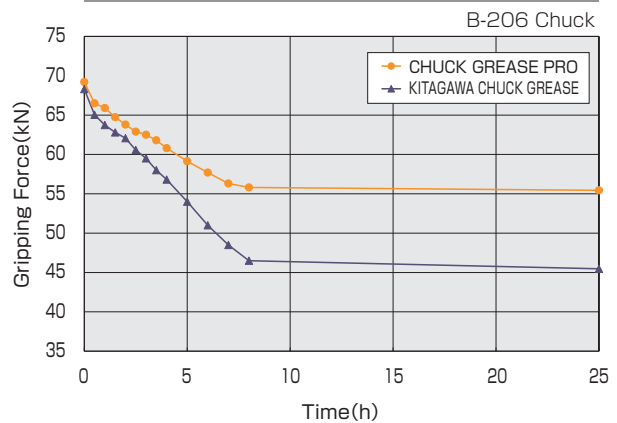

Fig.2 Grease Check Test



※The graphs show the grease performance, not the condition of using Chuck. Please refer to Chuck specification table for the condition of Chuck.

■ **Using method**

Grease the chuck with a commercial grease gun according to the instruction manual of the chuck as well as general grease.

■ **Features**

Color	Lemon yellow ~ yellow paste form	
Density g/cm ³	1.12	
Temperature range °F (°C)	18~300 (-28~149)	
Friction factor	0.06~0.1 (by LFW-1 Rotary Reciprocating Test Machine)	
NLGI Consistency	#2	
JIS K-2220 PS consistency	Mixing 60 times	265-295

工具・NCG
Jaws and Accessories



CHUCK

チャックグリース Chuck Grease グリースニップル Grease Nipple

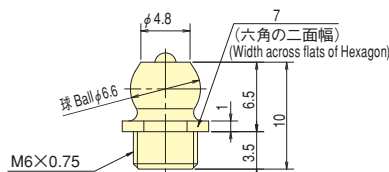

61S403879

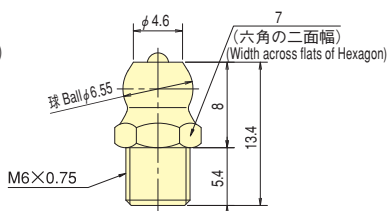

A M6 細目 Fine screw thread
(M6×0.75)

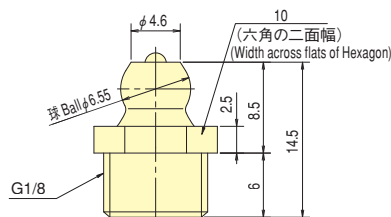

WA-100

■ グリースニップル挿入部 座グリ径 Grease nipple details

チャック型式 Model	座グリ径 Counterbore dia.	グリースニップル型式(図番) Grease nipple type (DWG No.)
BRO6/BRT06	φ15	61S403879
BRO8/BRT08	φ15	A M6 細目 Fine screw thread
BR10/BRT10	φ15	A M6 細目 Fine screw thread
BR12/BRT12	φ15	A M6 細目 Fine screw thread
B-204/BT204	φ12	61S403879
B-205/BT205	φ12	61S403879
B-206/BT206	φ15	A M6 細目 Fine screw thread
B-208/BT208	φ15	A M6 細目 Fine screw thread
B-210/BT210	φ15	A M6 細目 Fine screw thread
B-212/BT212	φ15	A M6 細目 Fine screw thread
B-215	φ15	A M6 細目 Fine screw thread
B series	φ15	A M6 細目 Fine screw thread
BB200 series	φ15	61S403879
BS306	φ15	61S403879
BS308	φ15	A M6 細目 Fine screw thread
BS310	φ15	A M6 細目 Fine screw thread
BL/BLT series	φ15	A M6 細目 Fine screw thread
HOH-206	φ15(ボデー Body) φ15(レバー Lever)	61S403879
HOH-208	φ15(ボデー Body) φ17(レバー Lever)	61S403879, A M6
HOH-10K	φ15(ボデー Body) φ17(レバー Lever)	A M6 細目 Fine screw thread
HOH-12K	φ20(ボデー Body) φ19(レバー Lever)	A M6 細目 Fine screw thread
HOH-15K	φ15(ボデー Body) φ21(レバー Lever)	A M6 細目 Fine screw thread
QB306	φ15	61S403879
QB308	φ15	A M6 細目 Fine screw thread
QB310	φ15	A M6 細目 Fine screw thread
QB312	φ15	A M6 細目 Fine screw thread
N-04	φ15	A M6 細目 Fine screw thread
N-05	φ15	A M6 細目 Fine screw thread
N-06	φ15	A M6 細目 Fine screw thread
N-08	φ15	A M6 細目 Fine screw thread
N-10	φ15	A M6 細目 Fine screw thread
N-12	φ15	A M6 細目 Fine screw thread
N-15	φ15	A M6 細目 Fine screw thread
N-18	φ15	A M6 細目 Fine screw thread
N-21	φ15	WA-100
N-24	φ15	WA-100
NLO4	φ15	A M6 細目 Fine screw thread
NLO6	φ15	A M6 細目 Fine screw thread
NLO8	φ15	A M6 細目 Fine screw thread
NL10	φ15	A M6 細目 Fine screw thread
NL12	φ15	A M6 細目 Fine screw thread
NL18	φ15	WA-100
ML/MLT/MLV series	φ15	A M6 細目 Fine screw thread
NT series	φ15	A M6 細目 Fine screw thread
NLT series	φ15	A M6 細目 Fine screw thread
HW-08	φ24	A M6 細目 Fine screw thread
HW-10	φ14	A M6 細目 Fine screw thread
HW-12	φ14	A M6 細目 Fine screw thread
HW-15	φ17	A M6 細目 Fine screw thread

チャック型式 Model	座グリ径 Counterbore dia.	グリースニップル型式(図番) Grease nipple type (DWG No.)
UVE-K series	φ12	A M6 細目 Fine screw thread
UB series	φ15	WA-100
UBR series	φ15	WA-100
HRS08	φ15	A M6 細目 Fine screw thread
DLR08	φ15	61S403879
DL206	φ15	61S403879
DL208	φ15	A M6 細目 Fine screw thread
DL210	φ15	A M6 細目 Fine screw thread
DL212	φ15	A M6 細目 Fine screw thread
PW/PWT series	φ15	A M6 細目 Fine screw thread
PUB series	φ15	A M6 細目 Fine screw thread
PU203	φ12	A M6 細目 Fine screw thread
PU204	φ15	A M6 細目 Fine screw thread
PU205	φ15	A M6 細目 Fine screw thread
PU206	φ15	A M6 細目 Fine screw thread
PU208	φ15	A M6 細目 Fine screw thread
PU210	φ15	A M6 細目 Fine screw thread
PU212	φ15	A M6 細目 Fine screw thread
PUE series	φ15	A M6 細目 Fine screw thread
LU series	φ15	A M6 細目 Fine screw thread
FGT05/FG05	φ12	A M6 細目 Fine screw thread
FGT06/FG06	φ15(ボデー Body) φ12(フィンガーブッシュ Finger bushing)	A M6 細目 Fine screw thread
FGT08/FG08	φ15	A M6 細目 Fine screw thread
FGT10/FG10	φ15	A M6 細目 Fine screw thread
FGT12/FG12	φ15	A M6 細目 Fine screw thread
FG-V series	φ15(プランジャ Plunger)	A M6 細目 Fine screw thread
FG-L series	φ15(プランジャ Plunger)	61S403879
FG52M	φ15(プランジャ Plunger)	61S403879
FG-Q series	φ14(プランジャ Plunger)	A M6 細目 Fine screw thread
JN/JN-T series	φ15	61S403879
JN-RA series	φ15	61S403879
JT series	φ15	61S403879
JS series	φ15	61S403879
AS04	φ15	61S403879
AS06	φ15	A M6 細目 Fine screw thread
AS08	φ15	A M6 細目 Fine screw thread
AS10	φ15	A M6 細目 Fine screw thread
AT04	φ15	61S403879
AT06	φ15	A M6 細目 Fine screw thread
AT08	φ15	A M6 細目 Fine screw thread
AT10	φ15	A M6 細目 Fine screw thread
PLS series	φ15	A M6 細目 Fine screw thread
JM200	φ15	A M6 細目 Fine screw thread

*KPCシリーズおよびSCシリーズはグリースの代わりに潤滑オイルを使用します。
*Lubrication oil is applied to KPC series and SC series instead of Chuck Grease.



CHUCK

静止型チャック把握力計 Jaw Force Tester JFT-S100A

掴んだ力が一目でわかる！ Gripping force can be checked at a glance!



作業性に優れたコンパクトタイプ。
チャックの把握力を定量化し、品質管理と安全性を向上します。

Compact design with excellent workability
Chuck gripping force is quantified, thus improving quality control and safety!

●小型一体型 Compact and integral

検出部と表示部は一体型、軽量1.3kgで、取り扱いが簡単！ Integrated detector and display. Easy to handle with a low weight of only 1.3kg!

●ゼロ調整不要 Zero adjustment not required

自動でゼロ調整されるため、直ちに測定可能！ Enables quick measurement with the automatic zero adjustment function!

●測定値記憶機能 Measured value memory function

必要な測定値を3点記憶でき、後での確認が可能！ Stores three required measured values, and enables later checking.

●節電機能 Power-saving function

自動電源遮断機能の使用で、節電可能！ Saves power with the automatic power-off function.

●警報メッセージ表示 Alarm message display

電池電圧低下、過大入力、自動ゼロ調整範囲外などのアラーム表示。 Battery voltage drop, excessive input, out-of-range zero adjustment, etc.

■寸法図 Dimensional Drawings

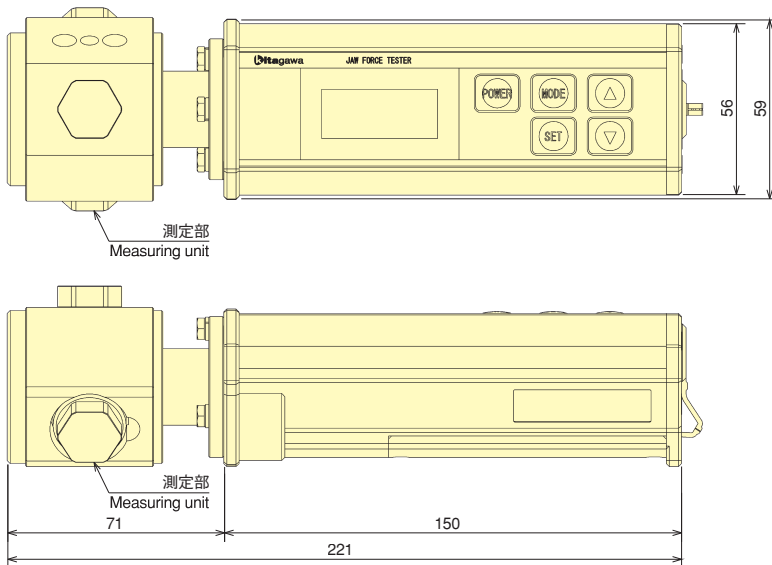

把握点数：3ヶ所の場合 When the number of gripping points is 3.

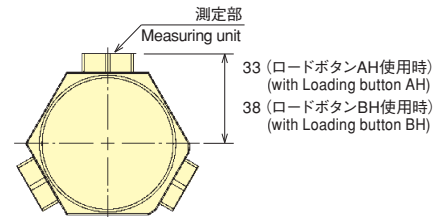

把握点数：2ヶ所の場合 When the number of gripping points is 2.

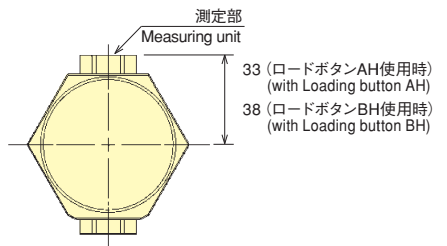

■仕様 Specifications

検出部(ロードセル) Loading Cell	
定格容量(爪当たり) Constant Capacity(per jaw)	100 kN
許容過負荷 Allowable load	150 %
把握点数 Gripped points	3箇所又は2箇所 Two or three positions
精度 Accuracy	±2 % R.O.
測定径 Measurable diameter	φ62~φ65mm (ロードボタンAH使用時) (with Loading button AH)
	φ62~φ75mm (ロードボタンBH使用時) (with Loading button BH)
表示部 Display	
計測範囲 Measuring range	0.5~100 kN
表示単位 Display unit	0.1 kN
操作スイッチ Operation Switch	シートスイッチパネル Sheet Switch Panel
表示部 Display unit	LCDキャラクタディスプレイ(8×2行バックライト付) LCD Character display (8×2 line with Back light)

その他 Others	
電源 Power source	リチウム電池 (CR123A×2本) Lithium Battery(CR123A)×2sets
外部電源 external power source	電源電圧 DC5V±5% Source voltage DC5V±5%
使用温度範囲 Operation Temperature	0~50℃
使用湿度範囲 Operation Humidity	80%RH以内 (結露しないこと) 80%RH or less
質量 Weight	1.3 kg
付属品 Accessory	ロードボタンAH (高さ7mm)×3ヶ Loading button A(H 7mm)×3pieces ロードボタンBH (高さ12mm)×3ヶ Loading button B(H 12mm)×3pieces 動作確認用電池×2本 Battery for operation check(CR123A×2pieces)

校正証明書はオプションとなります。
The calibration certificate is option.



CHUCK

ショートテーパチャックの 旋盤適合表

	型 式		第一主軸	第二主軸
			形状 (JIS)	形状 (JIS)
(株)池貝	AN	20N	A2-6	-
		25N	A2-8	-
	AX	30N	A2-8	-
	EC18	40B	A2-15	-
	ED18		A1-5	-
	FT		A1-5	-
		20	A2-6	-
	FX	20U,25U,20J,25J,600	A2-8	-
		10N	A2-5	-
		15N,MINI	スリット,フレット仕様	-
		20N	A1-6	-
		20II	A2-6	-
	LX20N		A2-8	-
			A1-6	-
	TC	8,10	スリット,フレット仕様	-
		15	A2-6	-
		25	A2-8	-
	TCR	15	A2-6	-
		25,25Y	A2-8	-
	TU	15	A2-6	-
TUR	15	A2-6	-	
TM25YS	サブ	A2-6	-	
	メイン	A2-8	-	
オークマ(株)	LB	2000EX	φ140フラット (A2-6)	φ140フラット
		2500EX	A2-6	-
		3000EX	A2-6(A2-8,A2-11)	φ140フラット
		4000EX	A2-8(A2-11)	-
		2000EXII	φ140フラット (A2-6)	φ140フラット
		2500EXII	A2-6	-
		3000EXII	A2-6(A2-8,A2-11)	φ140フラット
		4000EXII	A2-8(A2-11)	-
		35II	A2-8(A2-11,A2-15)	-
		45II	A2-11(A2-20)	-
		35III	A2-8(A2-11,A2-15)	-
		45III	A2-11(A2-20)	-
		GENOS	L250II	A2-6
	L400II		A2-8	-
	L2000		A2-6	-
	L3000		A2-8	-
	LU	300	φ140フラット(A2-6,A2-8)	-
		400	A2-8(A2-11)	-
		3000EX	A2-6	-
		4000EX	A2-8	-
35		A2-8(A2-11,A2-15)	-	
45		A2-11(A2-20)	-	
35II		A2-8(A2-11,A2-15)	-	
45II		A2-11(A2-20)	-	
LCS	250	A2-6(A2-8)	-	
	25	A2-8	-	
2SP	150H	φ140フラット	-	
	250H	A2-6	-	
	10HG	φ140フラット	φ140フラット	
	25HG	A2-6	A2-6	
	35HG,V40	A2-8	A2-8	
V60,V80		A2-11	A2-11	
	2500H	A2-6	-	
LFS	10-2SP	φ140フラット	φ140フラット	
	10M-2SP	φ140フラット	φ140フラット	
3SP	25HG	A2-6	A2-6	
LVT	300	A2-6	-	
	400	A2-8	-	
LAW	FII,2S	A2-8	-	
	V24	A2-11	-	
MAC TURN	250	A2-6(A2-8)	φ140フラット(A2-6)	
	350	A2-6(A2-8)	φ140フラット(A2-6,A2-8)	
	550	A2-8(A2-11)	A2-8	
MULTUS	B200	φ140フラット	-	
	B200(W)	φ140フラット	φ140フラット	
	B300	A2-6(A2-8)	-	
	B300(W)	A2-6(A2-8)	A2-6	
	B400	A2-8(A2-11)	-	
	B400(W)	A2-8(A2-11)	A2-8	
	B550	A2-11	-	
	B750	A2-11(A2-15,A2-20)	-	
	B200II	φ140フラット(A2-6)	-	
	B250II	A2-6(A2-8)	-	
	B300II	A2-6(A2-8)	-	
	B400II	A2-8(A2-11)	-	
	U3000	A2-6	-	
	U4000	A2-8	-	

	型 式		第一主軸	第二主軸	
			形状 (JIS)	形状 (JIS)	
オークマ(株)	U5000		A2-11	-	
		LT	200-M	φ140フラット(A2-6)	φ140フラット(A2-6)
			300-M	A2-6(A2-8)	A2-6(A2-8)
			2000EX	φ140フラット(A2-6)	φ140フラット(A2-6)
			3000EX	A2-6(A2-8)	A2-6(A2-8)
	LOC	650	A2-15(A2-20,φ725フラット)	-	
	LH(※)	55-N	A2-11(A2-15,A2-20)	-	
	HJ	18	φ140フラット	-	
		28,250	A2-6	-	
	HL	20	A2-6	-	
		35(L)	A2-8	-	
	SV	250	φ140フラット	-	
		40R	A2-8	-	
	V	60R,80R	A2-11	-	
		100R	φ380フラット	-	
		760EX	A2-11	-	
		920EX	A2-11	-	
VTT	70	A2-11	-		
VTM	65,100,80YB,120YB	A2-11	-		
※LHの取付けボルトはユニファイ仕様です。 ()内は大径、超大径仕様					
KITA KAKO	ACE		A2-6	-	
	mini ACE		A2-5	-	
	MT4	75,80,80-200,85	φ60フラット	-	
		120,120G,125	A2-5	-	
		170,200,250S	A2-6	-	
	MT3	120	A2-5	-	
		200	A2-6	-	
	TG1	52	A2-6	-	
	TM1	52	A2-6	-	
	V	5II,Turn	A2-6	-	
	VT1	200	A2-6	-	
		400,500	A2-8	-	
	VT2	500	A2-8	-	
	VT4	200	A2-6	-	
		450,550	A2-8	-	
	HS	4200	A2-6	-	
		VT4	350	A2-8	-
大日金属工業(株)	B70		A2-11	-	
	DGL	6,8,10	A1-6	-	
	DHK,DHM,N105,SH		A1-11	-	
	DLG	SH	A1-6	-	
		SHB	A1-11	-	
	DM	III	A2-11	-	
			A1-11	-	
	F	15	A2-5	-	
		20	A2-6	-	
		25	A1-6	-	
		30,35	A2-8	-	
	M95		A1-11	-	
	M	112,132,152	A2-15	-	
	(株)TAKISAWA	TAL	460,510	A1-6	-
600			A1-8	-	
TC		100	フラットφ140	-	
		200	A2-6orフラットφ140	-	
		350	A2-8	-	
		40	A2-11	-	
			-	-	
TK		2	A2-6	-	
TAC		360	A1-5	-	
		510,650	A2-8	-	
	780	A2-11	-		
	950	A2-11	-		
TSL	550,800	A1-5 ※開い合わせ要	-		
TT	160	フラットφ140	-		
	200	A2-6	-		
TMM	250	A2-8	A2-6		
	200	A2-6	A2-6		
TNR	200	A2-6	A2-6		
TCC	1100	フラットφ140	-		
	2100	A2-6	-		
TCN	2100	A2-6	-		
	2600	A2-8	-		
	3500	A2-8/A2-11	-		
TG	6000	A2-11/A2-15/A2-20	-		
	TT	500	フラットφ80	-	
	1100	フラットφ140	-		
	2100	フラットφ140	-		
	2600	A2-6	-		
	350	A2-8	-		

* (株)シマダマシンツール 旧メーカー名: KITA KAKO コーポレーション(株)含む

	型 式	第一主軸	第二主軸	
		形状 (JIS)	形状 (JIS)	
TKAWA	TK	2100	A2-6	
		2600	A2-8	
	TF	2600	A2-6	
	TCY	160	フラットφ140	フラットφ140
		200	A2-6	フラットφ140
	TS	2000	A2-5	A2-5
		3000	A2-6	フラットφ140
		4000	A2-8	フラットφ140
		5000	A2-8/A2-11	A2-6/フラットφ140
	TMX	2000	A2-6	A2-6
4000		A2-6/A2-8/A2-11	A2-6/A2-8	
TM	4000	A2-8	A2-6	
TMM	250	A2-8	A2-6	
ツガミ	PAN	1.2	スリット、アレット仕様	-
	NCM	45/160,70/160	スリット、アレット仕様	-
	NL	1	A1-6	-
中村留精密工業(株)	TMC	12	A2-5	-
		18	A2-6	-
	TMY	25	A2-6	-
	SC	100	A2-5	A2-5(OPT)
		150II	A2-5	-
		200	A2-6	A2-5(OPT)
		250	A2-6	A2-5(OPT)
		300II/II	A2-8	A2-5(OPT)
		450	A2-8	-
	TW	8	フラットφ108	フラットφ108
		10	A2-5	A2-5
		20	A2-6	A2-6
		30	A1-8	A1-8
	WT	100	A2-5	A2-5
		150	A2-5	A2-5
		250A	A2-6	A2-5
		250B	A2-5	A2-5
		250C	A2-5	A2-5
		300	A2-6	A2-6
	JX	250	A2-6 (OPT A2-8)	A2-6
	MX	100	A2-5 (OPT A2-6)	A2-5
	STW/STS	40	A1-8	A1-8
	WTW/WTS	150	ヒックホア φ65	A2-5 φ51
		150	ヒックホア φ51	A2-5 φ42
		150A	A2-5 φ42	A2-5 φ42
		150B	A2-5 φ32	A2-5 φ32
	NTX-W	φ61仕様	A2-6	A2-6
	NTX-S	φ71仕様	A1-8	A1-8
	NTJ	100	A2-5 (OPT A2-6)	A2-5 (OPT A2-6)
	NTM3	φ51仕様	A2-5	A2-5
	NTY3	100	A2-5 (OPT A2-6)	A2-5 (OPT A2-6)
	NTJX	φ51仕様	A2-5	A2-5
	NTRX	φ65仕様	A2-6	A2-5
		300/300II	A2-6 (OPT A2-8)	A2-6 (OPT A2-8)
	SUPER TURN	2AM	A2-5	-
		2BM	A1-8	-
		3	A1-6	-
		4	A1-8	-
		5	A1-8	-
		6	A1-11	-
		ABX	51SY,51TH2	A2-6
	BNC	64SY,64TH2	A2-8	A2-6
		34C5,42C5	スリット、アレット仕様	-
	BND	34C5,42C5	スリット、アレット仕様	-
		34S5,42S5	スリット、アレット仕様	-
		51C2	A2-6(拡大:A2-8)	-
	BNE	51S2,51SY2	A2-6(拡大:A2-8)	スリット、アレット仕様
		34S5,34SY5	スリット、アレット仕様	スリット、アレット仕様
		51S,51SY5	A2-6	スリット、アレット仕様
	BNJ	34S,34SY	スリット、アレット仕様	スリット、アレット仕様
42S,42SY		スリット、アレット仕様	スリット、アレット仕様	
51S,51SY2		A2-6(拡大:A2-8)	スリット、アレット仕様	
BX	20S,26S	スリット、アレット仕様	スリット、アレット仕様	
	LX	06E2	スリット、アレット仕様	-
		08C,08R	スリット、アレット仕様	-
08E2		A2-6	-	
LZ	01R2,01RY2	スリット、アレット仕様	-	
	02R2,02RY2	A2-6	-	
	GN	3200,3000,4	スリット、アレット仕様	-
3000W,3100W		スリット、アレット仕様	スリット、アレット仕様	
BM250		スリット、アレット仕様	スリット、アレット仕様	
村田機械(株)	MW	40	フラットノーズ	フラットノーズ
		50	フラットノーズ	フラットノーズ
	80	フラットノーズ	フラットノーズ	
	100G(HG),120G(HG)	A2-5	A2-5	
	180	A2-6	A2-6	
	200G	A2-6	A2-6	
	200GS(高出力仕様)	A2-8	A2-8	
	300G	A2-8	A2-8	
	400G	A2-11	A2-11	
	MS	20	フラットノーズ	-

	型 式	第一主軸	第二主軸		
		形状 (JIS)	形状 (JIS)		
村田機械(株)		50G,60G	A2-5	-	
		90	A2-6	-	
		100G	A2-6	-	
	MZ	60G	フラット	-	
		MD	60G	A2-5	-
			100G	A2-6	-
			120G	A2-5	A2-5
			180	A2-6	A2-6
	200G	A2-6	A2-6		
	MJ	60	A2-5	-	
		100	A2-6	-	
		200	フラットノーズ	-	
	MT	12	A2-5	A2-5	
		20,25	A2-6	A2-6	
		100	φ90A2-5/φ110A2-6	φ90A2-5/φ110A2-6	
		200	φ100,110,120A2-6/φ130A2-8	φ100,110,120A2-6/φ130A2-8	
		ML	400	A2-6	-
		MV	120(M)	A2-5	-
	WSC	6	フラット、アレット仕様	-	
	1SC	12	A2-5	-	
10M5000		A2-6	-		
MSC	12M5020	A2-8	-		
	22	A2-8	-		
2SC	15M5060,18M5090	A1-11	-		
3SC	24(M5240),28	A1-15	-		
ALX	1500	A2-5	-		
	2000	A2-6	-		
	2500	A2-8	-		
CL	1500	A2-5	-		
	2000A,2000B(大貫通穴仕様)	A2-6	-		
	Dura Turn	1530	A2-5	-	
	2030	A2-6	-		
	2050	A2-6	-		
	2550	A2-8	-		
	MT	(大貫通穴仕様)	A2-5	-	
		第二主軸付き	A2-5	A2-5	
		第二主軸付き(大貫通穴仕様)	A2-6	A2-5	
2000		A2-6	-		
2000(第二主軸付)		A2-6	A2-5		
2500,3000		A2-8	-		
NL	2500(第二主軸付),3000(第二主軸付)	A2-8	A2-6		
	4000Aタイプ	A2-11	-		
	4000Bタイプ	A2-15	-		
	4000Cタイプ	A1-20	-		
	4000Aタイプ(第二主軸付)	A2-11	A2-8		
	4000Bタイプ(第二主軸付)	A2-15	A2-8		
NLX	4000Cタイプ(第二主軸付)	A1-20	A2-8		
	1500	A2-5	-		
	1500(第二主軸付)	A2-5	A2-5		
	2000	A2-6	-		
	2000(第二主軸付)	A2-6	A2-5,A2-6(オプション)		
	2500,3000	A2-8	-		
NRX	2500(第二主軸付)	A2-8	A2-5,A2-6(オプション)		
	4000	A2-11,A2-15(オプション)	-		
	6000	A2-20	-		
NT	2000	A2-5	-		
	3100,3150	A2-5	-		
	3100(第二主軸付),3150(第二主軸付)	A2-5	A2-5		
	3200,4200	A2-6	-		
	3200(第二主軸付),4200(第二主軸付)	A2-6	A2-6		
	4250,4300	A2-8	-		
	4250(第二主軸付),4300(第二主軸付)	A2-8	A2-8		
	5400	A2-11	-		
	5400(第二主軸付)	A2-11	A2-11		
	6600B	A2-15	-		
NTX	6600B(第二主軸付)	A2-15	A2-15		
	6600C	A1-20	-		
	6600C(第二主軸付)	A1-20	A1-20		
	1000	A2-5	A2-5		
NZ	2000	A2-6	A2-6		
	1500	A2-5	A2-5		
NZX	1500(大貫通穴仕様)	A2-6	A2-6		
	1500	A2-5	A2-5		
RL	2000	A2-6,A2-8(オプション)	A2-6		
	2500	A2-6(オプション),A2-8	-		
	4000	A2-11,A2-15,A2-20	-		
	153	A2-5	A2-5		
	203	A2-6	A2-6		

*DMG森精機(株) 旧メーカー名: (株)アマダマシンツール ワシノ 機械(株)含む

型 式		第一主軸	第二主軸	
		形状 (JIS)	形状 (JIS)	
DMG 森精機(株)	SL	2500	A2-8	A2-8
		154	A2-5	—
		154(第二主軸付)	A2-5	A2-5
	SL	204	A2-6	—
		204(第二主軸付)	A2-6	A2-5
		2500Y,303A,303B(大貫通穴仕様)	A2-8	—
		403B,65B,65MC	A2-11	—
		403C,603B,803A,80A,80F	A2-15	—
		603C,65C,803,803B,80,80B	A1-20	—
		65A,75A	A1-11	—
		803C,80C	A2-20	—
		1000	A2-5	—
		VL	253A1	A2-8
	ZL	553	A2-11	—
		153	A2-5	—
		153(第二主軸付)	A2-5	A2-5
		203,253(高速回転仕様)	A2-6	—
203(第二主軸付)		A2-6	A2-5	
253,35		A2-8	—	
253S		A2-8	A2-5	
ZT	45B,45MC	A2-11	—	
	1000Y,1500Y	A2-5	A2-5	
	1500YB	A2-6	A2-5	
	1500YB(第二主軸大貫通穴仕様)	A2-6	A2-6	
	2500	A2-8	A2-8	
	S1500	A2-5	—	
L	S1500(大貫通穴仕様)	A2-6	—	
	3-J2,3-J3	A1-6	—	
	5-J2,5-J3	A2-8	—	
	6-J	A1-11	—	
	7-J	A2-11	—	
	12-C,15-C	A1-8	—	
LE(G)	19K	A1-6	—	
LEO(G)	80A,125A	A1-6	—	
LG	5,6,7,7M	A2-4	—	
	7F,8,8M,8MC	A2-6	—	
LJ	3A	A2-4	—	
	3B,5B	A2-6	—	
	6,10,6M(MC),10M(MC)	A2-8	—	
LN	32N,50N	A1-6	—	
LPT	35C	A1-5	—	
LR	55A	A1-5	—	
SH	5(M,D,DM)	A2-4	—	
SL	10,10S	A2-6	—	
	12	A2-8	—	
TH	5(M)	A2-4	—	
	10(M)	A2-6 (特殊時:A2-4)	—	
G	100,100M	Φ100フラット	—	
	04T,04-UP	特殊	—	
	05-UP	Φ95フラット	—	
	05,06,07,07-M	Φ100フラット	—	
	G-5	Φ80フラット	—	
	06,06P	Φ100フラット	—	
	07,07M	Φ100フラット	—	
	07-F	A2-6	—	
	J	1	Φ100フラット	—
		f-1	Φ80フラット	—
J-1,JJ-1		Φ100フラット	—	
3		A2-6	—	
A	5	A2-6/A2-8	—	
	i8,i8f	Φ56フラット/Φ80フラット	—	
	12,D-12	A2-6	—	
	18-S,D-18S	A2-8	—	
C	150Y,150SY	A2-6	—	
	3D	A2-6	—	
CT	4500	A2-11	—	
	5500	A2-20	—	
DT	20	A2-6	A2-6	
	25	A2-8	A2-8	
	200	A2-6	A2-6	
INTE	1004	A2-5	—	
	1004S	A2-5	A2-5	
	2004	A2-6	—	
	2004S	A2-6	A2-6	
	3004,4004	A2-8	—	
	3004S,4004S	A2-8	A2-8	
	410H2,410H2打テッポ仕様,420H2	A2-8	—	
	410HS2,410HS2打テッポ仕様,420HS2	A2-8	A2-8	
	420H2打テッポ仕様,500H2,650H2	A2-11	—	
	420HS2打テッポ仕様,500HS2,650HS2	A2-11	A2-11	
	500H2打テッポ仕様,650H2打テッポ仕様	A2-15	—	
	500HS2打テッポ仕様,650HS2打テッポ仕様	A2-15	A2-11	
	i-100	A2-5	—	
	i-100S	A2-5	A2-5	
	i-200	A2-6	—	
	i-200S	A2-6	A2-6	
	i-300	A2-8	—	
	i-300S	A2-8	A2-8	

ヤマザキマザック(株)

*DMG森精機(株) 旧メーカー名 : (株)アマダマシンツール ワシノ機械(株)含む

型 式		第一主軸	第二主軸	
		形状 (JIS)	形状 (JIS)	
ヤマザキマザック(株)	IVS	i-400	A2-8	—
		i-400S	A2-8	A2-8
		j-200	A2-6	—
		j-200S	A2-6	A2-5
		j-300	A2-8	—
		j-400	A2-8	—
	M	200	A2-6	—
		300	A2-8	—
		400	A2-11	—
	MP	4	A2-8	—
		5	A1-11	—
		6100	A2-5	A2-5
	MPN	4200,6200	A2-6	A2-6
		4300,6250,6300,6500	A2-8	A2-8
		8200Y	A2-6	A2-6
	NANO TURN		Φ85h6フラットノズ	—
	PM		A1-11	—
	QTN	100	A2-5	—
		100S	A2-5	A2-5
		150,200	A2-6	—
		200S	A2-6	A2-5
		250	A2-8	—
		300	A2-8	—
350,400		A2-11	—	
450		A2-15	—	
QT		100	A2-5	—
QTC		100S	A2-5	A2-5
	200	A2-6	—	
	200S	A2-6	A2-5	
	250	A2-8	—	
	250S	A2-8	A2-5	
	300	A2-8	—	
	350,400	A2-11	—	
	450	A2-15	—	
	ST	100	A2-6	—
	ST	200	A2-8	—
		300	A2-11	—
ST	450,50	A1-11	—	
	60	A2-15	—	
ST	80	A2-11	—	
X	100	A2-5	—	
	120	A2-5	フラット	
	150	A2-6	—	
	180	A2-6	—	
	200	A2-6 (A2-8 opt)	A2-5	
	S700	A2-6, A2-8	—	
	12	A2-5	—	
	20	A2-6	A2-6	
	XT	6	A2-5	—
	XT	8	A2-6	—
		500	A2-6 (A2-8 opt)	A2-6 (A2-8 opt)
	XWT	10	A2-8	—
	XC	100	A2-5	—
150		Φ170フラット	—	
XL	100	A2-5	—	
	150	A2-6 (A2-8 opt)	—	
	200	A2-6 (A2-8)	A2-5	
SX	150	Φ170フラット	—	
	XD	7	凸Φ75フラット	コレットチャック専用
5		フラット	フラット	
8		フラット	フラット	
8t		フラット	フラット	
10i		A2-5	A2-5	
XW		30	A3-S2	—
	30PLUS	A2-3	—	
	40	A2-5	—	
	50	凹Φ82.55フラット	凹Φ82.55フラット	
	60	A2-5 (A2-4 opt)	A2-5 (A2-4 opt)	
	80	A2-5	A2-5	
	130	A2-6	A2-6	
	150	A2-6	A2-6	
	180	A2-6	A2-6	
	200	A2-8	凸Φ75フラット	
XY	120	A2-5	凸Φ75フラット	
	1000	A2-5	A2-5	
	2000	A2-6 (A2-8 opt)	A2-6	
	mini-TURN		凸Φ75フラット	—
TOP-TURNII		A仕様	A2-5	
USL	B仕様	A2-5	—	
	300	A3-S2	—	
J-WAVE	480	A3-S2	—	
	GSL		凹Φ82.55フラット	
GSL	10	A2-5	—	
	15	A2-6	—	
VERSEC-neo		A1-5	—	

ヤマザキマザック(株)

高松機械工業(株)

VERSEC-neo



CHUCK

Compatibilities of Lathes to Short Taper Chucks

Model		First Spindle Nose (JIS)	Second Spindle Nose (JIS)	
IKEGAI	AN	20N	A2-6	
		25N	A2-8	
	AX	30N	A2-8	
	EC18	40B	A2-15	
	ED18		A1-5	
	FT		A1-5	-
		20	A2-6	-
	FX	20U,25U,20J,25J,600	A2-8	-
		10N	A2-5	-
		15N,MINI	Straight, plate	-
		20N	A1-6	-
		20II	A2-6	-
		25W,25II	A2-8	-
	LX20N		A1-6	-
	TC	8,10	Straight, plate	-
		15	A2-6	-
		25	A2-8	-
	TCR	15	A2-6	-
		25,25Y	A2-8	-
	TU	15	A2-6	-
TUR	15	A2-6	-	
TM25YS	Sub	A2-6	-	
	Maine	A2-8	-	
OKUMA	LB	2000EX	φ140Flat (A2-6)	φ140Flat
		2500EX	A2-6	-
		3000EX	A2-6(A2-8,A2-11)	φ140Flat
		4000EX	A2-8(A2-11)	-
		2000EX II	φ140Flat (A2-6)	φ140Flat
		2500EX II	A2-6	-
		3000EX II	A2-6(A2-8,A2-11)	φ140Flat
		4000EX II	A2-8(A2-11)	-
		35II	A2-8(A2-11,A2-15)	-
		45I	A2-11(A2-20)	-
	GENOS	L250II	A2-6	-
		L400II	A2-8	-
		L2000	A2-6	-
		L3000	A2-8	-
	LU	300	φ140Flat(A2-6,A2-8)	-
		400	A2-8(A2-11)	-
		3000EX	A2-6	-
		4000EX	A2-8	-
		35	A2-8(A2-11,A2-15)	-
		45	A2-11(A2-20)	-
35II		A2-8(A2-11,A2-15)	-	
45II		A2-11(A2-20)	-	
LCS	250	A2-6(A2-8)	-	
	25	A2-8	-	
2SP	150H	φ140Flat	-	
	250H	A2-6	-	
	10HG	φ140Flat	φ140Flat	
	25HG	A2-6	A2-6	
	35HG,V40	A2-8	A2-8	
	V60,V80	A2-11	A2-11	
	2500H	A2-6	-	
LFS	10-2SP	φ140Flat	φ140Flat	
	10M-2SP	φ140Flat	φ140Flat	
3SP	25HG	A2-6	A2-6	
LVT	300	A2-6	-	
	400	A2-8	-	
LAW	F II, 2S	A2-8	-	
	V24	A2-11	-	
MAC TURN	250	A2-6(A2-8)	φ140Flat(A2-6)	
	350	A2-6(A2-8)	φ140Flat(A2-6,A2-8)	
	550	A2-8(A2-11)	A2-8	
MULTUS	B200	φ140Flat	-	
	B200(W)	φ140Flat	φ140Flat	
	B300	A2-6(A2-8)	-	
	B300(W)	A2-6(A2-8)	A2-6	
	B400	A2-8(A2-11)	-	
	B400(W)	A2-8(A2-11)	A2-8	
	B550	A2-11	-	
	B750	A2-11(A2-15,A2-20)	-	
	B200II	φ140Flat(A2-6)	-	
	B250II	A2-6(A2-8)	-	
	B300II	A2-6(A2-8)	-	
	B400II	A2-8(A2-11)	-	
	U3000	A2-6	-	
	U4000	A2-8	-	

*SHIMADA Machine tool Drives includes former manufacturer : KITAKO

Model		First Spindle Nose (JIS)	Second Spindle Nose (JIS)	
OKUMA	U5000	A2-11	-	
	LT	200-M	φ140Flat(A2-6)	φ140Flat(A2-6)
		300-M	A2-6(A2-8)	A2-6(A2-8)
		2000EX	φ140Flat(A2-6)	φ140Flat(A2-6)
		3000EX	A2-6(A2-8)	A2-6(A2-8)
	LOC	650	A2-15(A2-20,φ725Flat)	-
	LH(※)	55-N	A2-11(A2-15,A2-20)	-
	HJ	18	φ140Flat	-
		28,250	A2-6	-
	HL	20	A2-6	-
		35(L)	A2-8	-
	SV	250	φ140Flat	-
		40R	A2-8	-
	V	60R,80R	A2-11	-
		100R	φ380Flat	-
760EX		A2-11	-	
920EX		A2-11	-	
VTM	70	A2-11	-	
VTM	65,100,80YB,120YB	A2-11	-	
※Mounting bolts of LH are unifying specifications. Numerical values in () are large diameter as option.				
KITAKO	ACE		A2-6	
	mini ACE		A2-5	
	MT4	75,80,80-200,85	φ60Flat	-
		120,120G,125	A2-5	-
		170,200,250S	A2-6	-
	MT3	120	A2-5	-
		200	A2-6	-
	TG1	52	A2-6	-
	TM1	52	A2-6	-
	V	5II,Turn	A2-6	-
VT1	200	A2-6	-	
VT2	400,500	A2-8	-	
	500	A2-8	-	
VT4	200	A2-6	-	
	450,550	A2-8	-	
HS	4200	A2-6	-	
	350	A2-8	-	
DANICHI KINZOKU KOGYO	B70		A2-11	
	DGL	6,8,10	A1-6	
	DHK,DHM,N105,SH		A1-11	-
		DLG	SH	A1-6
	DLG		A1-11	-
		DM	III	A1-11
	F		A2-11	-
		15	A2-5	-
		20	A2-6	-
	M95	25	A1-6	-
		30,35	A2-8	-
	M	112,132,152	A1-11	-
	TAKISAWA	TAL	460,510	A2-15
		TC	600	A1-6
100			A1-8	-
200			Flatφ140	-
350			A2-6 or Flatφ140	-
TK		40	A2-8	-
			A2-11	-
		2	A2-6	-
		360	A1-5	-
TAC		510,650	A2-8	-
		780	A2-11	-
		950	A2-11	-
		550,800	A2-11	-
TSL		160	A1-5 Inquiry required	-
TT	200	Flatφ140	-	
	200	A2-6	-	
TMM	250	A2-8	A2-6	
	200	A2-6	A2-6	
TNR	200	A2-6	A2-6	
	1100	Flatφ140	-	
TCC	2100	A2-6	-	
	2600	A2-8	-	
	3500	A2-8/A2-11	-	
TCN	2100	A2-6	-	
	6000	A2-11/A2-15/A2-20	-	
TG	500	Flatφ80	-	
	1100	Flatφ140	-	
	2100	Flatφ140	-	
	2600	A2-6	-	
	3500	A2-8	-	

第4・10号
Laws and Accessories

		Model	First Spindle Nose (JIS)	Second Spindle Nose (JIS)	
TAKISAWA	TK	2100	A2-6		
		2600	A2-8		
	TF	2600	A2-6		
	TCY	160	Flat ϕ 140	Flat ϕ 140	
		200	A2-6	Flat ϕ 140	
		2000	A2-5	A2-5	
	TS	3000	A2-6	Flat ϕ 140	
		4000	A2-8	Flat ϕ 140	
		5000	A2-8/A2-11	A2-6/Flat ϕ 140	
	TMX	2000	A2-6	A2-6	
4000		A2-6/A2-8/A2-11	A2-6/A2-8		
TM	4000	A2-8	A2-6		
TMM	250	A2-8	A2-6		
TSUGAMI	PAN	1,2	Straight, plate	-	
	NCM	45/160,70/160	Straight, plate	-	
	NL	1	A1-6	-	
1H		A1-5	-		
NAKAMURA	TMC	12	A2-5	-	
		18	A2-6	-	
	TMY	25	A2-6	-	
	SC	100	A2-5	A2-5(OPT)	
		150II	A2-5	-	
		200	A2-6	A2-5(OPT)	
		250	A2-6	A2-5(OPT)	
		300II/II	A2-8	A2-5(OPT)	
		450	A2-8	-	
	TW	8	Flat ϕ 108	Flat ϕ 108	
		10	A2-5	A2-5	
		20	A2-6	A2-6	
		30	A1-8	A1-8	
	WT	100	A2-5	A2-5	
		150	A2-5	A2-5	
		250A	A2-6	A2-5	
		250B	A2-5	A2-5	
		250C	A2-5	A2-5	
		300	A2-6	A2-6	
	JX	250	A2-6 (OPT A2-8)	A2-6	
	MX	100	A2-5 (OPT A2-6)	A2-5	
	STW/STS	40	A1-8	A1-8	
	WTW/WTS	150 Big bore	A2-6 ϕ 65	A2-5 ϕ 51	
		150 Big bore	A2-5 ϕ 51	A2-5 ϕ 42	
		150A	A2-5 ϕ 42	A2-5 ϕ 42	
		150B	A2-5 ϕ 32	A2-5 ϕ 32	
	NTX-W	ϕ 61	A2-6	A2-6	
	NTX-S	ϕ 71	A1-8	A1-8	
	NTJ	100	A2-5 (OPT A2-6)	A2-5 (OPT A2-6)	
	NTM3	ϕ 51	A2-5	A2-5	
	NTY3	100	A2-5 (OPT A2-6)	A2-5 (OPT A2-6)	
	NTJX	ϕ 51	A2-5	A2-5	
	NTRX	ϕ 65	A2-6	A2-5	
		300/300II	A2-6 (OPT A2-8)	A2-6 (OPT A2-8)	
	SUPER TURN	2AM	A2-5	-	
		2BM	A1-8	-	
		3	A1-6	-	
		4	A1-8	-	
		5	A1-8	-	
		6	A1-11	-	
	CITIZEN MACHINERY	ABX	51SY,51TH2	A2-6	A2-6
			64SY,64TH2	A2-8	A2-6
		BNC	34C5,42C5	Straight, plate	-
		BND	34C5,42C5	Straight, plate	-
			34S5,42S5	Straight, plate	-
			51C2	A2-6(Enlarged A2-8)	-
BNE		51S2,51SY2	A2-6(Enlarged A2-8)	Straight, plate	
		34S5,34SY5	Straight, plate	Straight, plate	
		51S,51SY5	A2-6	Straight, plate	
BNJ		34S,34SY	Straight, plate	Straight, plate	
		42S,42SY	Straight, plate	Straight, plate	
		51S,51SY2	A2-6(Enlarged A2-8)	Straight, plate	
BX		20S,26S	Straight, plate	Straight, plate	
LX		06E2	Straight, plate	-	
		08C,08R	Straight, plate	-	
		08E2	A2-6	-	
LZ	01R2,01RY2	Straight, plate	-		
	02R2,02RY2	A2-6	-		
	3200,3000,4	Straight, plate	-		
GN	3000W,3100W	Straight, plate	Straight, plate		
	BM250	Straight, plate	Straight, plate		
MURATA	MW	40	Flat nose	Flat nose	
		50	Flat nose	Flat nose	
	80	Flat nose	Flat nose		
	100G(HG),120G(HG)	A2-5	A2-5		
	180	A2-6	A2-6		
	200G	A2-6	A2-6		
	200GS(High power)	A2-8	A2-8		
	300G	A2-8	A2-8		
	400G	A2-11	A2-11		
	MS	20	Flat nose	-	

		Model	First Spindle Nose (JIS)	Second Spindle Nose (JIS)
MURATA		50G,60G	A2-5	-
		90	A2-6	-
		100G	A2-6	-
	MZ	60G	Flat	-
		60G	A2-5	-
		100G	A2-6	-
		120G	A2-5	A2-5
		180	A2-6	A2-6
	MD	200G	A2-6	A2-6
		60	A2-5	-
		100	A2-6	-
	MJ	200	Flat nose	-
		12	A2-5	A2-5
		20,25	A2-6	A2-6
	MT	100	ϕ 90A2-5/ ϕ 110A2-6	ϕ 90A2-5/ ϕ 110A2-6
		200	ϕ 100,110,120A2-6/ ϕ 130A2-8	ϕ 100,110,120A2-6/ ϕ 130A2-8
		400	A2-6	-
	ML	120(M)	A2-5	-
	WSC	6	Flat, plate	-
	1SC	12	A2-5	-
		10M5000	A2-6	-
	MSC	12M5020	A2-8	-
		22	A2-8	-
	2SC	15M5060,18M5090	A1-11	-
	3SC	24(M5240),28	A1-15	-
	ALX	1500	A2-5	-
		2000	A2-6	-
		2500	A2-8	-
	CL	1500	A2-5	-
		2000A,2000B(Large bore spec)	A2-6	-
Dura Turn	1530	A2-5	-	
	2030	A2-6	-	
	2050	A2-6	-	
	2550	A2-8	-	
MT	(Large bore spec)	A2-5	-	
	(Large bore spec)	A2-6	-	
	With 2nd main spindle	A2-5	A2-5	
	With 2nd main spindle(Large bore spec)	A2-6	A2-5	
	2000	A2-6	-	
	2000(With 2nd main spindle)	A2-6	A2-5	
	2500,3000	A2-8	-	
	2500(With 2nd main spindle)	A2-8	A2-6	
	4000A Type	A2-11	-	
	4000B Type	A2-15	-	
4000C Type	A1-20	-		
4000A Type(With 2nd main spindle)	A2-11	A2-8		
4000B Type(With 2nd main spindle)	A2-15	A2-8		
4000C Type(With 2nd main spindle)	A1-20	A2-8		
NL	1500	A2-5	-	
	1500(With 2nd main spindle)	A2-5	A2-5	
	2000	A2-6	-	
	2000(With 2nd main spindle)	A2-6	A2-5	
NLX	2500,3000	A2-8	-	
	2500(With 2nd main spindle)	A2-8	A2-5	
	1500	A2-5	-	
	1500(With 2nd main spindle)	A2-5	A2-5	
NRX	2000	A2-6	-	
	2000(With 2nd main spindle)	A2-6	A2-5,A2-6(Option)	
	2500,3000	A2-8	-	
	2500(With 2nd main spindle)	A2-8	A2-5,A2-6(Option)	
NT	4000	A2-11,A2-15(Option)	-	
	6000	A2-20	-	
	2000	A2-5	-	
	3100,3150	A2-5	-	
NTX	3100(With 2nd main spindle),3150(With 2nd spindle)	A2-5	A2-5	
	3200,4200	A2-6	-	
	3200(With 2nd main spindle),4200(With 2nd spindle)	A2-6	A2-6	
	4250,4300	A2-8	-	
	4250(With 2nd main spindle),4300(With 2nd spindle)	A2-8	A2-8	
	5400	A2-11	-	
NZ	5400(With 2nd main spindle)	A2-11	A2-11	
	6600B	A2-15	-	
	6600B(With 2nd main spindle)	A2-15	A2-15	
	6600C	A1-20	-	
NTZ	6600C(With 2nd main spindle)	A1-20	A1-20	
	1000	A2-5	A2-5	
	2000	A2-6	A2-6	
NZX	2000,3000	A2-8	A2-8	
	1500	A2-5	A2-5	
	1500(Large bore spec)	A2-6	A2-6	
RL	1500	A2-5	A2-5	
	2000	A2-6,A2-8(Option)	A2-6	
	2500	A2-6(Option),A2-8	-	
	4000	A2-11,A2-15,A2-20	-	
RL	153	A2-5	A2-5	
	203	A2-6	A2-6	

*DMG MORI SEIKI includes former manufacturer : Amada Machine Tools, WASINO

Model		First Spindle Nose (JIS)	Second Spindle Nose (JIS)
DMG MORI SEIKI	2500	A2-8	A2-8
	SL 154	A2-5	—
	154(With 2nd main spindle)	A2-5	A2-5
	204	A2-6	—
	SL 204(With 2nd main spindle)	A2-6	A2-5
	2500Y,303A,303B(Large bore spec)	A2-8	—
	403B,65B,65MC	A2-11	—
	403C,603B,803A,80A,80F	A2-15	—
	603C,65C,803,803B,80,80B	A1-20	—
	65A,75A	A1-11	—
	803C,80C	A2-20	—
	1000	A2-5	—
	VL 253A1	A2-8	—
	553	A2-11	—
	ZL 153	A2-5	—
	153(With 2nd main spindle)	A2-5	A2-5
	203,253(High speed spec.)	A2-6	—
	203(With 2nd main spindle)	A2-6	A2-5
	253,35	A2-8	—
	253S	A2-8	A2-5
	45B,45MC	A2-11	—
	ZT 1000Y,1500Y	A2-5	A2-5
	1500YB	A2-6	A2-5
	1500YB(With 2nd main spindle, Large bore spec)	A2-6	A2-6
	2500	A2-8	A2-8
	S1500	A2-5	—
	S1500(Large bore spec)	A2-6	—
	L 3-J2,3-J3	A1-6	—
	5-J2,5-J3	A2-8	—
	6-J	A1-11	—
	7-J	A2-11	—
	12-C,15-C	A1-8	—
	LE(G) 19K	A1-6	—
	LEO(G) 80A,125A	A1-6	—
	LG 5,6,7,7M	A2-4	—
	7F,8,8M,8MC	A2-6	—
	LJ 3A	A2-4	—
	3B,5B	A2-6	—
	6,10,6M(MC),10M(MC)	A2-8	—
	LN 32N,50N	A1-6	—
	LPT 35C	A1-5	—
	LR 55A	A1-5	—
	SH 5(M,D,DM)	A2-4	—
	SL 10,10S	A2-6	—
	12	A2-8	—
	TH 5(M)	A2-4	—
	10(M)	A2-6 (at special A2-4)	—
	G 100,100M	φ100Flat	—
	04T,04-UP	Special	—
	05-UP	φ95Flat	—
	05,06,07,07-M	φ100Flat	—
	G-5	φ80Flat	—
	06,06P	φ100Flat	—
	07,07M	φ100Flat	—
07-F	A2-6	—	
J 1	φ100Flat	—	
f-1	φ80Flat	—	
J-1,JJ-1	φ100Flat	—	
3	A2-6	—	
5	A2-6/A2-8	—	
A i8,i8f	φ56Flat/φ80Flat	—	
12,D-12	A2-6	—	
18-S,D-18S	A2-8	—	
150Y,150SY	A2-6	—	
C 3D	A2-6	—	
YAMAZAKI MAZAK	CT 4500	A2-11	—
	5500	A2-20	—
	DT 20	A2-6	A2-6
	25	A2-8	A2-8
	200	A2-6	A2-6
	INTE 1004	A2-5	—
	1004S	A2-5	A2-5
	2004	A2-6	—
	2004S	A2-6	A2-6
	3004,4004	A2-8	—
	3004S,4004S	A2-8	A2-8
	410H2,410H2 Option spec.,420H2	A2-8	—
	410HS2,410HS2 Option spec.,420HS2	A2-8	A2-8
	420H2 Option spec.,500H2,650H2	A2-11	—
	420HS2 Option spec.,500HS2,650HS2	A2-11	A2-11
	500H2 Option spec.,650H2 Option spec.	A2-15	—
	500HS2 Option spec.,650HS2 Option spec.	A2-15	A2-11
	i-100	A2-5	—
	i-100S	A2-5	A2-5
	i-200	A2-6	—
	i-200S	A2-6	A2-6
	i-300	A2-8	—
	i-300S	A2-8	A2-8

Model		First Spindle Nose (JIS)	Second Spindle Nose (JIS)	
YAMAZAKI MAZAK	i-400	A2-8	—	
	i-400S	A2-8	A2-8	
	j-200	A2-6	—	
	j-200S	A2-6	A2-5	
	j-300	A2-8	—	
	j-400	A2-8	—	
	IVS 200	A2-6	—	
	300	A2-8	—	
	400	A2-11	—	
	M 4	A2-8	—	
	5	A1-11	—	
	MP 6100	A2-5	A2-5	
	4200,6200	A2-6	A2-6	
	4300,6250,6300,6500	A2-8	A2-8	
	MPN 8200Y	A2-6	A2-6	
	NANO TURN	φ85h6 Flat nose	—	
	PM	A1-11	—	
	QTN 100	A2-5	—	
	100S	A2-5	A2-5	
	150,200	A2-6	—	
	200S	A2-6	A2-5	
	250	A2-8	—	
	300	A2-8	—	
	350,400	A2-11	—	
	450	A2-15	—	
	QT 100	A2-5	—	
	100S	A2-5	A2-5	
	200	A2-6	—	
	200S	A2-6	A2-5	
	250	A2-8	—	
	250S	A2-8	A2-5	
	300	A2-8	—	
	350,400	A2-11	—	
	450	A2-15	—	
	QTC 100	A2-6	—	
	200	A2-8	—	
	300	A2-11	—	
	ST 450,50	A1-11	—	
	60	A2-15	—	
	80	A2-11	—	
	TAKAMATSU	X 100	A2-5	—
		120	A2-5	Flat
		150	A2-6	—
		180	A2-6	—
		200	A2-6 (A2-8 opt)	A2-5
		S700	A2-6,A2-8	—
		12	A2-5	—
		20	A2-6	A2-6
		XT 6	A2-5	—
		8	A2-6	—
		XTT 500	A2-6 (A2-8 opt)	A2-6 (A2-8 opt)
		XWT 10	A2-8	—
		XC 100	A2-5	—
		150	φ170Flat	—
XL 100		A2-5	—	
150		A2-6 (A2-8 opt)	—	
200		A2-6(A2-8)	A2-5	
SX 150		φ170Flat	—	
XD 7		convexφ75Flat	Collect chuck only	
5		Flat	Flat	
8		Flat	Flat	
8t		Flat	Flat	
10i		A2-5	A2-5	
XW 30		A3-S2	—	
30PLUS		A2-3	—	
40		A2-5	—	
50		concaveφ82.55Flat	concaveφ82.55Flat	
60		A2-5 (A2-4 opt)	A2-5 (A2-4 opt)	
80		A2-5	A2-5	
130		A2-6	A2-6	
150	A2-6	A2-6		
180	A2-6	A2-6		
200	A2-8	convexφ75Flat		
XY 120	A2-5	convexφ75Flat		
1000	A2-5	A2-5		
2000	A2-6 (A2-8 opt)	A2-6		
mini-TURN	convexφ75Flat	—		
TOP-TURNII A	A2-5	—		
B	A2-5	—		
USL 300	A3-S2	—		
480	A3-S2	—		
J-WAVE	concaveφ82.55Flat	—		
GSL 10	A2-5	—		
15	A2-6	—		
SANDA UMS	VERSEC-neo	A1-5	—	



CHUCK

旋盤主軸端とショートテーパ チャック取付けについて

●旋盤主軸端について

旋盤主軸端に関する規格はJISの外にISO, ASA, DIN等があります。

日本国内の主要旋盤メーカーで製作されている旋盤の主軸端の大多数はJIS-A1, A2 (ISO-A1, A2)で一部ASA-A1, A2が採用されています。各規格の主軸端寸法は同寸法ですが、面板(チャックやバックプレート)の寸法公差には数ミクロンのちがいがあります。

●主軸端に対するショートテーパ(直付けタイプ)チャックの取付について

主軸端に対するショートテーパチャックのテーパ径はわずかに小さく、若干の締め代をもっています。チャックをはめ込んだ際に相互の取付端面にわずかな隙間が生じて密着せず、チャックの取付ボルトのねじ込みによって密着するものとなっています。(取付ボルト穴のある面が取付端面です。)そのためチャック取付の際、片締めとならないようにそれぞれの取付ボルトを順に均等に締付けることが肝要です。何かの原因により締め代の大きい場合と、締め代がなく径方向に隙間が生じる場合があり、前者ではチャック取付の際本体を歪ませ、また後者の場合は取付誤差を累加したりして把握精度を低下させます。

同様にスクロールチャックでも主軸端テーパの小端面内取付で取付ける場合は、過大な締め代をおこなうと本体に歪が生じ、ハンドル操作またはチャックの動きが極端に重くなります。また、締め代が大きい程その傾向は大きくなりますので注意下さい。

※P.125 ショートテーパチャックの旋盤適合表を参照下さい。

テーパ修正を必要とする場合は、修正を別途申し受けますのでご相談下さい。

主軸端形状図

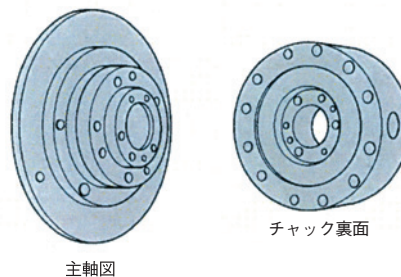

主軸端寸法図

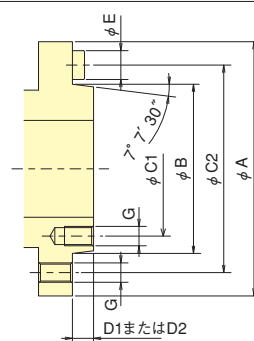

JIS B 6109-1: 2005

“工作機械-旋盤の主軸端及びチャックの接続寸法-第1部: 円すい接続”より抜粋

符号	主軸端番号				
	5	6	8	11	15
A	133	165	210	280	380
B	82.563	106.375	139.719	196.869	285.775
C1	61.9	82.6	111.1	165.1	247.6
C2	104.8	133.4	171.4	235	330.2
D1	14.288	15.875	17.462	19.050	20.638
D2	13	14	16	18	19
E	15.9	19.05	23.8	28.6	34.9
G	M10	M12	M16	M20	M24 (EJISはM22)

注1: C1は主軸端形状がA1形の場合のみ

注2: D1は主軸端形状がA1形、D2はA2形の場合

●分割爪スクロールチャック(ショートテーパ) JN-RAシリーズのご注文に際して

ご注文の際はお近くの販売店または弊社にお客様ご使用の旋盤メーカー名・型式をご連絡下さい。

メーカーにより主軸端面の寸法公差が異なる場合があるため、チャックのテーパ部の修正が必要となる場合があります。(納期、価格が変わりますのでご注意ください。)

また、JN-RAシリーズは、標準でメートルねじのチャック本体取付けボルトを同梱しています。

メーカーによりチャック本体取付けにインチねじ(ユニファイボルトまたはウイトネジ)を採用している場合がありますのでご相談下さい。



CHUCK

For mounting a short taper chuck to lathe spindle end

●About lathe spindle end

Standards covering the lathe spindle end are stipulated in ISO, ASA, DIN, etc except JIS.

Japan major lathe manufacturers manufacture the great majority of lathe spindle end parts at standards of JIS-A1, A2 (ISO-A1, A2). However, a part of lathe spindle end parts is manufactured at ASA-A1, A2.

Although the spindle end dimensions according to each standard are the same, the dimensional tolerance of a face plate (chuck or back plate) varies by a few microns.

●Mounting the short taper (direct type) chuck for spindle end

The taper diameter of the short taper chuck for the spindle end is small slightly and the chuck has the some amount of interference (tolerance). A little gap occurs in mutual mounting end faces when the chuck is set. The chuck is closely touched by screwing mounting bolts. (The face having mounting bolt holes is the mounting face.) Tighten the chuck evenly by screwing bolts diagonally.

When interference (tolerance) of the chuck is large or small, any gap may occur in diameter direction. In the former case, the chuck may be deformed at the time of chuck mounting. In the latter case, a gripping accuracy becomes low for increasing a mounting error.

Similarly, the scroll chuck will also be deformed by tightening it excessively when mounting the chuck to the small end face of spindle end taper. Thus, the handle operation or chuck motion becomes heavy extremely.

Moreover, take care since the more interference, the more failure becomes large.

※See a lathe matching list of the short taper chuck.

When you need taper correction, since correction expense is required separately, please consult our company.

●For order of separate jaw scroll chucks JN-RA for short taper

When placing an order, establish contact with your agent or our company to advise a manufacturer name and type of a lathe used in a customer shop.

Since the dimensional tolerance of spindle end face may vary by manufacturers, it is necessary to correct the taper of the chuck rear body. (Please understand that there is a fluctuation of a delivery date and a price.)

Moreover, JN-RA types are standard and chuck mounting M bolts are packed together with the chuck. Since each chuck mounting bolt is manufactured at inch (UNIH1 bolt or wit screw) by manufacturers, confer with our company.

Nose shape figure

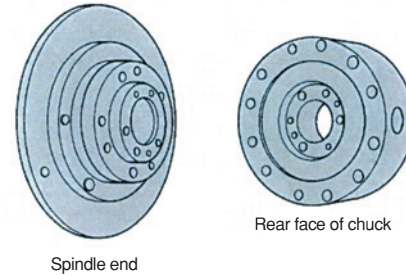

Nose dimension figure

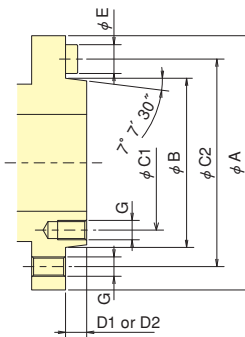

JIS B 6109-1: 2005

Machine Tool - Lathe Spindle End and Chuck mounting dimensions Part 1: Extract "Mounting Short Taper"

Code	Spindle Nose Number				
	5	6	8	11	15
A	133	165	210	280	380
B	82.563	106.375	139.719	196.869	285.775
C1	61.9	82.6	111.1	165.1	247.6
C2	104.8	133.4	171.4	235	330.2
D1	14.288	15.875	17.462	19.050	20.638
D2	13	14	16	18	19
E	15.9	19.05	23.8	28.6	34.9
G	M10	M12	M16	M20	M24 (M22 for Former JIS)

Note 1: C1 is Shown on A1 Spindle Nose

Note 2: D1 is shown on A1 Spindle Nose and D2 is done on A2 one



CHUCK

スクロールチャックのパーツ ご注文に際して

●スクロールチャックのハードジョー(内・外・分割(上爪/下爪))ご注文に際して

- ・SC series … 3・4・5・14・16インチのボデーは鋳鉄製。
JN / JN-T JN-RA series … 6~12インチのボデーはスチール製。

SCシリーズは、チャックボデーにジョー嵌め合部のアリ溝を現物合わせし、ワーク把握面を含み研磨を実施しています。原則チャックをお預かりし、修理として芯研磨を実施いたします。

JNシリーズは、芯研磨はジョーの把握面の部位となります。

分割爪チャック(JN-T / JN-RA)の下爪(爪受け台)の場合、SCシリーズと同様チャック本体のアリ溝部の現物合わせが必要となります。

しかし、お客様の強いご要望によりパーツのみの出荷も対応しますが、上記内容により本体にジョーが挿入できない等、お客様ご使用のチャックに対して合わせ研磨を実施していないために精度不良が生じる場合があります。

お客様納入後による返品は、原則お引き受けできませんのでご注意ください。

■ハードジョー (SC series)

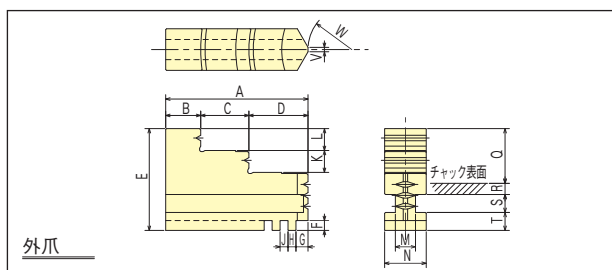
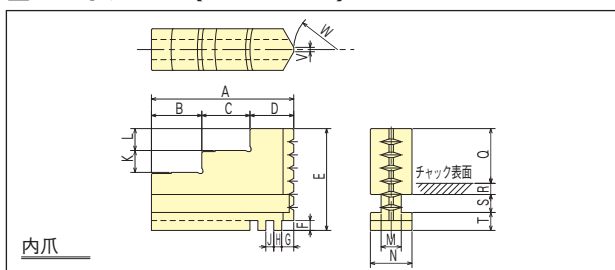

■SC series ジョー寸法表

チャック型式		A	B	C	D	E	F	G	H	J	K	L	M	N	Q	R	S	T	V	W
SC-3	内爪	35	14	10	11	29	2.5	4	2.11	2.11	6	6	5.7	11	15	2.75	6.55	4.7	1	R 7.5
	外爪	35	9	10	16	29	2.5	4	2.11	2.11	6	6	5.7	11	15	2.75	6.55	4.7	1	R 7.5
SC-4	内爪	42	16	13	13	34.5	3.5	4.5	2.54	2.54	7	7	7.2	14	18	3.75	6.55	6.2	1.5	R11
	外爪	42	10	13	19	34.5	3.5	4.5	2.54	2.54	7	7	7.2	14	18	3.75	6.55	6.2	1.5	R11
SC-5	内爪	50	20	15	15	40	4	4	3.175	3.175	8	8	7.2	16	20	4.1	8.2	7.7	1.5	R15
	外爪	50	14	15	21	40	4	4	3.175	3.175	8	8	7.2	16	20	4.1	8.2	7.7	1.5	R15
SC-14	内爪	132	49	42	41	93.5	7	8	5.08	5.08	18	18	19	35	52	9.3	16.2	16	5	R47
	外爪	132	40	41	51	93.5	7	8	5.08	5.08	18	18	19	35	52	9.3	16.2	16	5	R47
SC-16	内爪	146	52	50	44	102	7	10.5	5.08	5.08	20	20	23	40	58	11.8	16.2	16	6	R53
	外爪	146	43	50	53	102	7	10.5	5.08	5.08	20	20	23	40	58	11.8	16.2	16	6	R53

■ハードジョー (JN series)

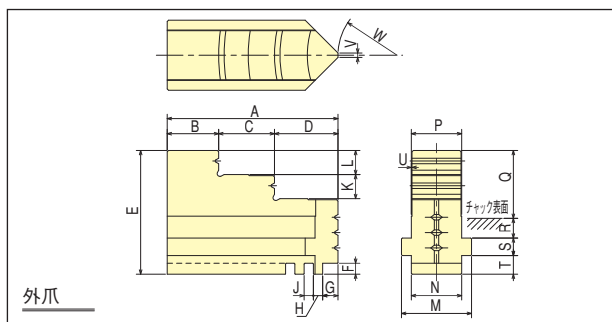
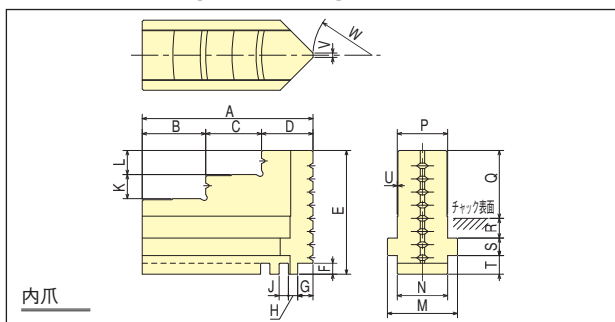

■JN series ジョー寸法表

チャック型式		A	B	C	D	E	F	G	H	J	K	L	M	N	P	Q	R	S	T	U	V	W
JN06	内爪	66	26.5	19	20.5	48.5	4.5	5.5	3.629	3.629	9	9	29	21	21	27	8	6.5	7	0.3	2	R19.5
	外爪	66	18	19	29	48.5	4.5	5.5	3.629	3.629	9	9	29	21	21	27	8	6.5	7	0.3	2	R19.5
JN07	内爪	78	29	25.5	23.5	56.5	5	7	4.233	4.233	11	11	32	23	23	31	9	8	8.5	0.3	2	R27
	外爪	78	20.5	25.5	32	56.5	5	7	4.233	4.233	11	11	32	23	23	31	9	8	8.5	0.3	2	R27
JN09	内爪	88	34	28	26	62.5	5	7.5	4.233	4.233	13	13	38	27	27	33	10.5	9.5	9.5	0.3	3	R34.5
	外爪	88	24	28	36	62.5	5	7.5	4.233	4.233	13	13	38	27	27	33	10.5	9.5	9.5	0.3	3	R34.5
JN10	内爪	98	36.5	32	29.5	66.5	5	7.5	4.233	4.233	14	14	38	27	27	37	10.5	9.5	9.5	0.3	3	R42
	外爪	98	28	32	38	66.5	5	7.5	4.233	4.233	14	14	38	27	27	37	10.5	9.5	9.5	0.3	3	R42
JN12	内爪	113	41.5	36.5	35	81	6	8	5.08	5.08	15	15	44	31	31	44	14.5	11	11	0.3	4	R42
	外爪	113	33	36.5	43.5	81	6	8	5.08	5.08	15	15	44	31	31	44	14.5	11	11	0.3	4	R42

■ JN・JN-T・JN-RA把握範囲表

型式	把握範囲							
	外径把握					内径把握		
	A1	A2	A3	A4	ソフトジョー	B1	B2	ソフトジョー
SC-3(F)	2~35	33~55	53~70	2~35	(2~70)	24~44	42~64	(24~64)
SC-4(F)	3~43	41~69	67~95	3~43	(3~95)	29~57	55~84	(29~84)
SC-5(F)	3~46	44~77	75~110	3~46	(3~110)	33~67	65~100	(33~100)
JN06	3~64	62~112	110~160	3~64	-	48~100	98~150	-
JN06T	3~64	62~112	110~160	-	3~160	55~104	102~150	55~150
JN06R	3~64	62~112	110~160	-	-	55~104	102~150	-
JN07	4~72	70~126	124~180	4~72	-	56~114	112~170	-
JN07T	4~68	66~124	122~180	-	4~180	62~117	115~170	62~170
JN07R	4~68	66~124	122~180	-	-	62~117	115~170	-
JS07	4~72	70~126	124~180	4~72	-	56~114	112~170	-
JT07	-	-	-	-	4~180	-	-	62~170
JN08R	4~76	74~138	136~200	-	-	62~127	125~190	-
JN09	5~84	82~150	150~220	5~84	-	62~137	135~210	-
JN09T	5~80	78~150	148~220	-	5~220	70~141	139~210	70~210
JN09R	5~80	78~150	148~220	-	-	70~141	139~210	-
JS09	5~84	82~152	150~220	5~84	-	62~137	135~210	-
JT09	-	-	-	-	5~220	-	-	70~210
JN10	5~96	94~178	176~260	5~96	-	70~161	159~250	-
JN10T	5~94	92~177	176~260	-	5~260	80~166	164~250	80~250
JN10R	5~94	92~177	176~260	-	-	80~166	164~250	-
JN12	10~108	108~204	202~300	10~108	-	86~189	187~290	-
JN12T	10~108	108~204	202~300	-	10~300	90~191	189~290	90~290
JN12R	10~108	108~204	202~300	-	-	90~191	189~290	-
SC-14	25~118	116~210	208~315	25~118	-	107~188	186~290	-
SC-16	25~132	130~215	213~360	25~132	-	113~212	210~340	-

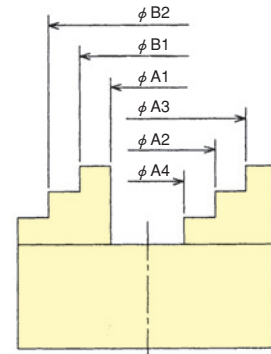

SC(F)/JN/JS type

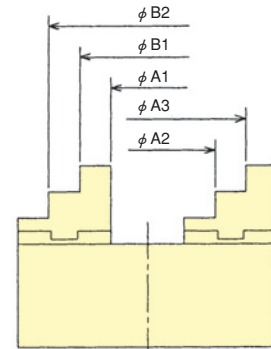

JN-T/JN-R type

■ チャックハンドル寸法表

型式	F1	F2	F3	F4	F5
SC-3	65	15	8	110	7
SC-4	70	17	8	140	8
SC-5	75	20	10	170	8
JN06	120	20	10	210	10
JN07	160	20	12	240	11
JN09	160	22	12	290	12
JN10	160	22	12	360	12
JN12	200	26	16	390	14
SC-14	140	30	16	450	15
SC-16	140	30	16	450	15
IC-4	75	12	8	120	6
IC-6	100	13	8	150	8
IC-8	130	15	10	200	10
IC-10	150	18	12	250	10
IC-12	170	19	12	300	12
IC-14	170	19	12	300	12
IC-16	220	22	16	400	14
IC-18	220	22	16	400	14

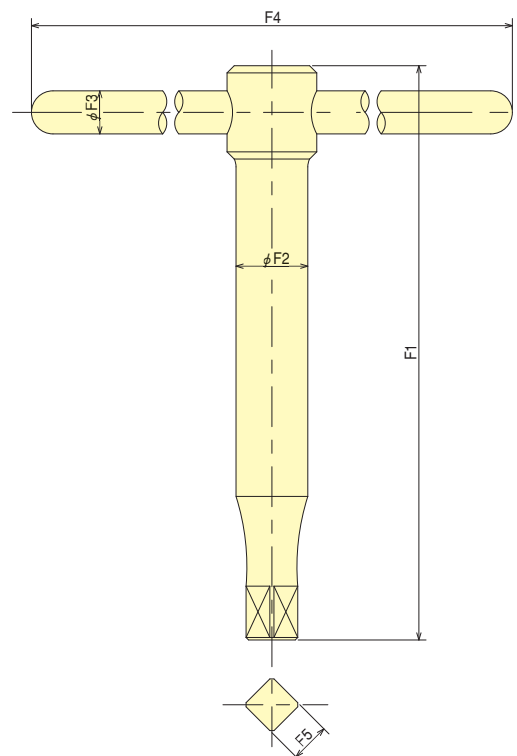



CHUCK

For order of Scroll Chuck parts

- For order of hard jaws of scroll chuck [Internal, External & 2 piece jaw (Top and Base jaws)]
 - SC series ... Bodies of 3, 4, 5, 14 and 16 inches are made of cast iron.
 - JN / JN-T JN-RA series ... Bodies of 12 -16 inches are made of steel.

In SC series, Hard jaws are ground with the chuck and it is required the tolerance combination on the jaw fitting. As a general rule, Gripping face is ground concentrically in our shop as repair.

In JN series, the tolerance combination is not required but Gripping face is need to be ground concentrically.

In case of Base jaw for the 2 piece jaw chucks(JN-T/JN-RA), the tolerance combination is also required as well as SC type chucks.

At customer's strong demand, only parts will be supplied however, problem may occur, i.e. Accuracy is not satisfied because jaws are not ground with the existing chuck body.

■ Hard Jaw (SC series)

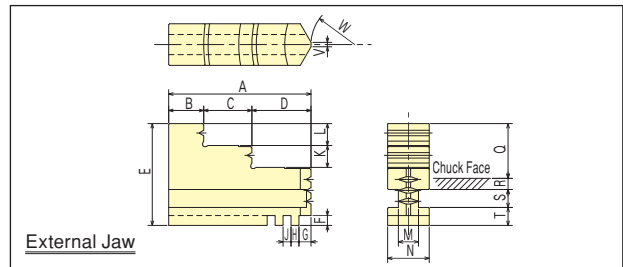
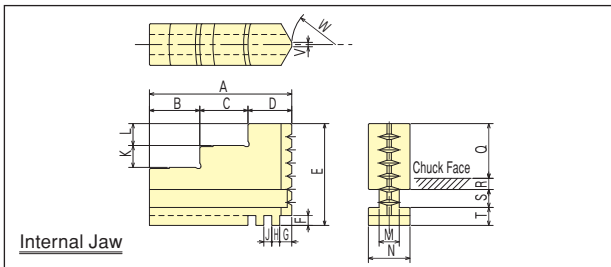

■ SC series Jaw Dimensions

Model		A	B	C	D	E	F	G	H	J	K	L	M	N	Q	R	S	T	V	W
SC-3	Internal jaw	35	14	10	11	29	2.5	4	2.11	2.11	6	6	5.7	11	15	2.75	6.55	4.7	1	R 7.5
	External jaw	35	9	10	16	29	2.5	4	2.11	2.11	6	6	5.7	11	15	2.75	6.55	4.7	1	R 7.5
SC-4	Internal jaw	42	16	13	13	34.5	3.5	4.5	2.54	2.54	7	7	7.2	14	18	3.75	6.55	6.2	1.5	R11
	External jaw	42	10	13	19	34.5	3.5	4.5	2.54	2.54	7	7	7.2	14	18	3.75	6.55	6.2	1.5	R11
SC-5	Internal jaw	50	20	15	15	40	4	4	3.175	3.175	8	8	7.2	16	20	4.1	8.2	7.7	1.5	R15
	External jaw	50	14	15	21	40	4	4	3.175	3.175	8	8	7.2	16	20	4.1	8.2	7.7	1.5	R15
SC-14	Internal jaw	132	49	42	41	93.5	7	8	5.08	5.08	18	18	19	35	52	9.3	16.2	16	5	R47
	External jaw	132	40	41	51	93.5	7	8	5.08	5.08	18	18	19	35	52	9.3	16.2	16	5	R47
SC-16	Internal jaw	146	52	50	44	102	7	10.5	5.08	5.08	20	20	23	40	58	11.8	16.2	16	6	R53
	External jaw	146	43	50	53	102	7	10.5	5.08	5.08	20	20	23	40	58	11.8	16.2	16	6	R53

■ Hard Jaw (JN series)

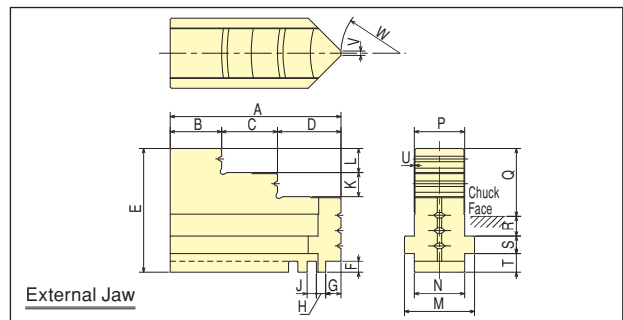
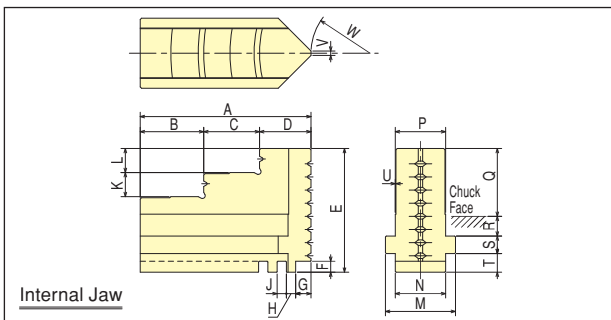

■ JN series Jaw Dimensions

Model		A	B	C	D	E	F	G	H	J	K	L	M	N	P	Q	R	S	T	U	V	W
JN06	Internal jaw	66	26.5	19	20.5	48.5	4.5	5.5	3.629	3.629	9	9	29	21	21	27	8	6.5	7	0.3	2	R19.5
	External jaw	66	18	19	29	48.5	4.5	5.5	3.629	3.629	9	9	29	21	21	27	8	6.5	7	0.3	2	R19.5
JN07	Internal jaw	78	29	25.5	23.5	56.5	5	7	4.233	4.233	11	11	32	23	23	31	9	8	8.5	0.3	2	R27
	External jaw	78	20.5	25.5	32	56.5	5	7	4.233	4.233	11	11	32	23	23	31	9	8	8.5	0.3	2	R27
JN09	Internal jaw	88	34	28	26	62.5	5	7.5	4.233	4.233	13	13	38	27	27	33	10.5	9.5	9.5	0.3	3	R34.5
	External jaw	88	24	28	36	62.5	5	7.5	4.233	4.233	13	13	38	27	27	33	10.5	9.5	9.5	0.3	3	R34.5
JN10	Internal jaw	98	36.5	32	29.5	66.5	5	7.5	4.233	4.233	14	14	38	27	27	37	10.5	9.5	9.5	0.3	3	R42
	External jaw	98	28	32	38	66.5	5	7.5	4.233	4.233	14	14	38	27	27	37	10.5	9.5	9.5	0.3	3	R42
JN12	Internal jaw	113	41.5	36.5	35	81	6	8	5.08	5.08	15	15	44	31	31	44	14.5	11	11	0.3	4	R42
	External jaw	113	33	36.5	43.5	81	6	8	5.08	5.08	15	15	44	31	31	44	14.5	11	11	0.3	4	R42

精造・NCS型
 Jaws and Accessories

■ Gripping range

Model	Gripping range							
	External gripping					Internal gripping		
	A1	A2	A3	A4	Soft Jaw	B1	B2	Soft Jaw
SC-3(F)	2~35	33~55	53~70	2~35	(2~70)	24~44	42~64	(24~64)
SC-4(F)	3~43	41~69	67~95	3~43	(3~95)	29~57	55~84	(29~84)
SC-5(F)	3~46	44~77	75~110	3~46	(3~110)	33~67	65~100	(33~100)
JN06	3~64	62~112	110~160	3~64	-	48~100	98~150	-
JN06T	3~64	62~112	110~160	-	3~160	55~104	102~150	55~150
JN06R	3~64	62~112	110~160	-	-	55~104	102~150	-
JN07	4~72	70~126	124~180	4~72	-	56~114	112~170	-
JN07T	4~68	66~124	122~180	-	4~180	62~117	115~170	62~170
JN07R	4~68	66~124	122~180	-	-	62~117	115~170	-
JS07	4~72	70~126	124~180	4~72	-	56~114	112~170	-
JT07	-	-	-	-	4~180	-	-	62~170
JN08R	4~76	74~138	136~200	-	-	62~127	125~190	-
JN09	5~84	82~150	150~220	5~84	-	62~137	135~210	-
JN09T	5~80	78~150	148~220	-	5~220	70~141	139~210	70~210
JN09R	5~80	78~150	148~220	-	-	70~141	139~210	-
JS09	5~84	82~152	150~220	5~84	-	62~137	135~210	-
JT09	-	-	-	-	5~220	-	-	70~210
JN10	5~96	94~178	176~260	5~96	-	70~161	159~250	-
JN10T	5~94	92~177	176~260	-	5~260	80~166	164~250	80~250
JN10R	5~94	92~177	176~260	-	-	80~166	164~250	-
JN12	10~108	108~204	202~300	10~108	-	86~189	187~290	-
JN12T	10~108	108~204	202~300	-	10~300	90~191	189~290	90~290
JN12R	10~108	108~204	202~300	-	-	90~191	189~290	-
SC-14	25~118	116~210	208~315	25~118	-	107~188	186~290	-
SC-16	25~132	130~215	213~360	25~132	-	113~212	210~340	-

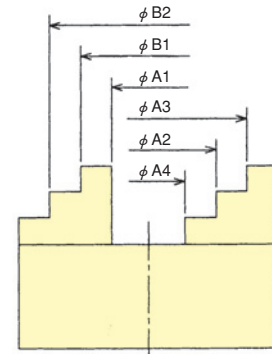

SC(F)/JN/JS type

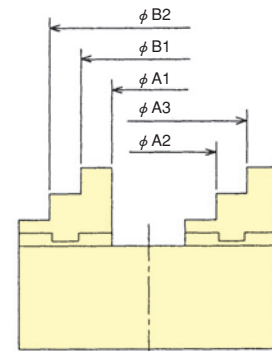

JN-T/JN-R type

■ Chuck handle Dimensions

Model	F1	F2	F3	F4	F5
SC-3	65	15	8	110	7
SC-4	70	17	8	140	8
SC-5	75	20	10	170	8
JN06	120	20	10	210	10
JN07	160	20	12	240	11
JN09	160	22	12	290	12
JN10	160	22	12	360	12
JN12	200	26	16	390	14
SC-14	140	30	16	450	15
SC-16	140	30	16	450	15
IC-4	75	12	8	120	6
IC-6	100	13	8	150	8
IC-8	130	15	10	200	10
IC-10	150	18	12	250	10
IC-12	170	19	12	300	12
IC-14	170	19	12	300	12
IC-16	220	22	16	400	14
IC-18	220	22	16	400	14

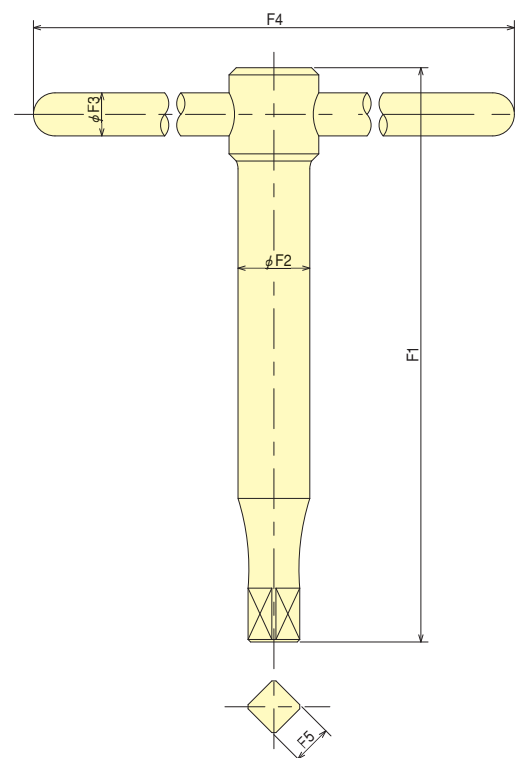



America Contact

- **KITAGAWA - NORTHTECH INC.**
Tel. +1 847-310-8787 Fax. +1 847-310-9484
- **KITAGAWA MEXICO S.A. DE C.V**
Tel. +52 449-917-8825 Fax. +52 449-971-1966

301 E. Commerce Dr, Schaumburg, IL. 60173 USA
<https://www.kitagawa-usa.com>
 Circuito Progreso No. 102, Parque Industrial Logistica Automotriz, Aguascalientes, Ags., C.P.20340, Mexico

Europe Contact

- **KITAGAWA EUROPE LTD.**
Tel. +44 1725-514000 Fax. +44 1725-514001
- KITAGAWA EUROPE GmbH**
Tel. +49 2102-123-78-00 Fax. +49 2102-123-78-69
- KITAGAWA EUROPE GmbH Poland Office**
Tel. +48 607-39-8855
- KITAGAWA EUROPE GmbH Czech Office**
Tel. +420 603 856 122
- KITAGAWA EUROPE GmbH Romania Office**
Tel. +40 727-770-329
- KITAGAWA EUROPE GmbH Hungary Office**
Tel. +36 30-510-3550

Unit 1 The Headlands, Downton, Salisbury, Wiltshire SP5 3JJ, United Kingdom
<https://www.kitagawa.global/en>
 Borsigstrasse 3.40880, Ratingen Germany
<https://www.kitagawa.global/de>
 44-240 Zory, ul. Niepodleglosci 3 Poland
<https://www.kitagawa.global/pl>
 Purkynova 125, 612 00 Brno, Czech Republic
<https://www.kitagawa.global/cz>
 Strada Heliului 15, Bucharest 1, 013991, Romania
<https://www.kitagawa.global/ro>
 Dery T.u.5, H-9024 Győr, Hungary
<https://www.kitagawa.global/hu>

Asia Contact

- **KITAGAWA INDIA PVT LTD.**
Tel. +91 80-2976-5200 Fax. +91 80-2976-5205
- **KITAGAWA TRADING (THAILAND) CO., LTD.**
Tel. +66 2-712-7479 Fax. +66 2-712-7481
- **Kitagawa Corporation (Shanghai)**
Tel. +86 21-6295-5772 Fax. +86 21-6295-5792
- **Kitagawa Corporation (Shanghai) Guangzhou Office**
Tel. +86 20-2885-5276
- **DEAMARK LIMITED**
Tel. +886 2-2393-1221 Fax. +886 2-2395-1231
- **KITAGAWA KOREA AGENT CO., LTD.**
Tel. +82 2-2026-2222 Fax. +82 2-2026-2113

Plot No.42, 2nd Phase Jigani Industrial Area, Jigani, Bangalore – 560105, Karnataka, India
<https://www.kitagawa.global/in>
 9th FL, Home Place Office Building, 283/43 Sukhumvit 55 Rd. (Thonglor 13), Klongton-Nua, Wattana, Bangkok 10110, Thailand
<https://www.smri.asia/jp/kitagawa/>
 Room 308 3F Building B. Far East International Plaza, No.317 Xian Xia Road, Chang Ning, Shanghai, 200051, China
<https://www.kitagawa.com.cn>
 B07, 25/F, West Tower, Yangcheng International Trading Centre, No.122, East Tiyu Road, Tianhe District, Guangzhou, China
 No. 6, Lane 5, Lin Sen North Road, Taipei, Taiwan
<https://www.deamark.com.tw/>
 803 Ho, B-Dong, Woolim Lion's Valley, 371-28 Gasan-Dong, Gumcheon-Gu, Seoul, Korea
<http://www.kitagawa.co.kr>

Oceania Contact

- **DIMAC TOOLING PTY.LTD.**
Tel. +61 3-9561-6155 Fax. +61 3-9561-6705

69-71 Williams Rd, Dandenong South, Victoria, 3175 Australia
<https://www.dimac.com.au>

● 日本語対応可能
 Japanese speaker available



<https://www.kiw.co.jp>
<https://www.kitagawa.com>
<https://www.kitagawa.com.cn>

株式会社 北川鉄工所 Kitagawa Global hand Company
 Kitagawa Corporation

本社 HEAD OFFICE	広島県府中市元町77-1 77-1 Motomachi, Fuchu-shi, Hiroshima, 726-8610, Japan	〒726-8610	Tel.(0847)40-0561 Tel. +81 847-40-0561	Fax.(0847)45-8911 Fax. +81 847-45-8911
東京営業課	埼玉県さいたま市北区吉野町1-405-1	〒331-9634	Tel.(048)667-3469	Fax.(048)663-4678
仙台支店駐在	宮城県仙台市若林区大和町4-15-13	〒984-0042	Tel.(022)232-6732(代)	Fax.(022)232-6739
名古屋営業課	愛知県名古屋市中川区上高畑2-62	〒454-0873	Tel.(052)363-0371(代)	Fax.(052)362-0690
大阪営業課	大阪府大阪市住之江区北加賀屋3-2-9	〒559-0011	Tel.(06)6685-9065(代)	Fax.(06)6684-2025
広島営業課	広島県府中市元町77-1	〒726-8610	Tel.(0847)40-0541	Fax.(0847)46-1721
九州支店駐在	福岡県福岡市博多区板付7-6-39	〒812-0888	Tel.(092)501-2102(代)	Fax.(092)501-2103
海外営業課	広島県府中市元町77-1	〒726-8610	Tel.(0847)40-0526	Fax.(0847)45-8911

・仕様・外観は改良のため、予告なく変更することがあります。 ・カタログと実際の商品の色とは印刷の関係で多少異なる場合もあります。
 ・カタログ記載内容／令和7年5月
 ・本カタログ記載の商品は「外国為替及び外国貿易法」の「輸出貿易管理令」及び「外国為替令」の規制対象貨物です。
 同法に基づき、経済産業省大臣による輸出許可が必要となる場合がございます。日本国外へ持ち出される場合は、あらかじめ当社にご相談ください。
 ・Specifications and outside appearance are subject to change without notice due to ongoing research and development. ・The color of the actual product may be different from the catalogue's due to printing matters.
 ・Catalogue contents as of 2025.5
 ・The products herein are controlled under Japanese Foreign Exchange and Foreign Trade Control Act.
 In the event of importing and/or exporting the products, you are obliged to consult KITAGAWA as well as your government for the related regulation prior to any transaction.