



CHUCK

# パワーウイングチャック

## PW(C) series

PW-C型はコンペイティング（心補償把握）仕様です。センタやピン穴基準で位置決めされたワークに倣って把握します。寸法やその他の仕様はPW型と同一です。

### ワーク素材を引込む安定把握 しっかり掴んで荒加工に最適

#### ●把握安定性が高く重切削が可能です

ワークをラジアル方向へ把握し、さらに強力な引きつけ作用でチャック端面に密着させますから把握が確実で安定しており重切削が可能です。

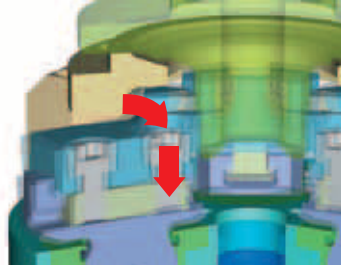

#### ●長時間安定した把握力が得られます

マスタジョーが球体構造となっていますからシール性がよく長時間安定した把握力が得られます。

#### ●グリス密封性が大きく向上しました

シール（1）に加え、ボデーとリアボデーの合わせ面にもシール（2）を挿入することにより封入グリスの密封性を大きく向上させました。

#### ●左右のイコライズは最大5°まで可能です

ばらつきのあるワークにも左右5°ジョーがイコライズし安定把握します。

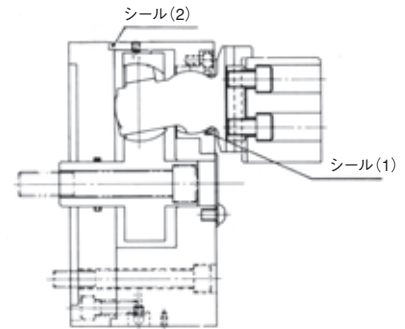
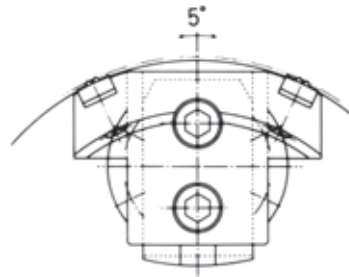

#### ●最大テーパ20°までの把握が可能です

抜勾配のついた casting・forging black surfaceでもグリップピースで確実にテーパ部を把握します。

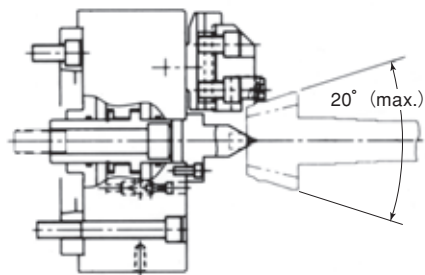

#### ■グリップピースの種類

\*グリップピースはワークの条件によってそれぞれ選定されます。

##### U-Type

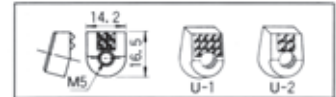

##### U-2S



##### R-Type

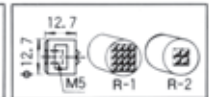

\*CE対応品

### ワーク実績

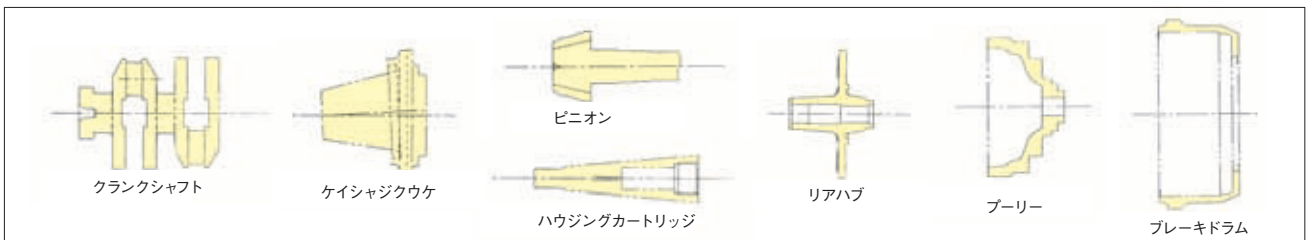

### 把握状態例

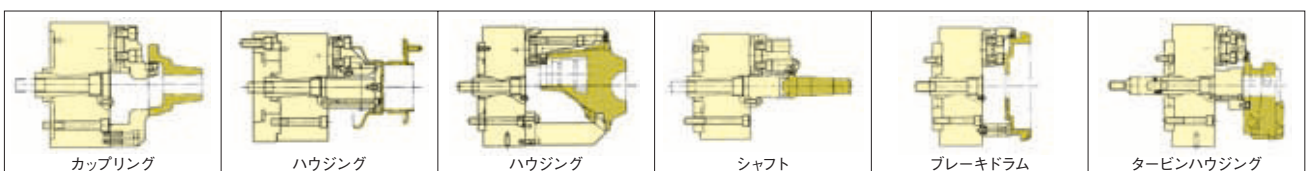

### ■ 寸法図

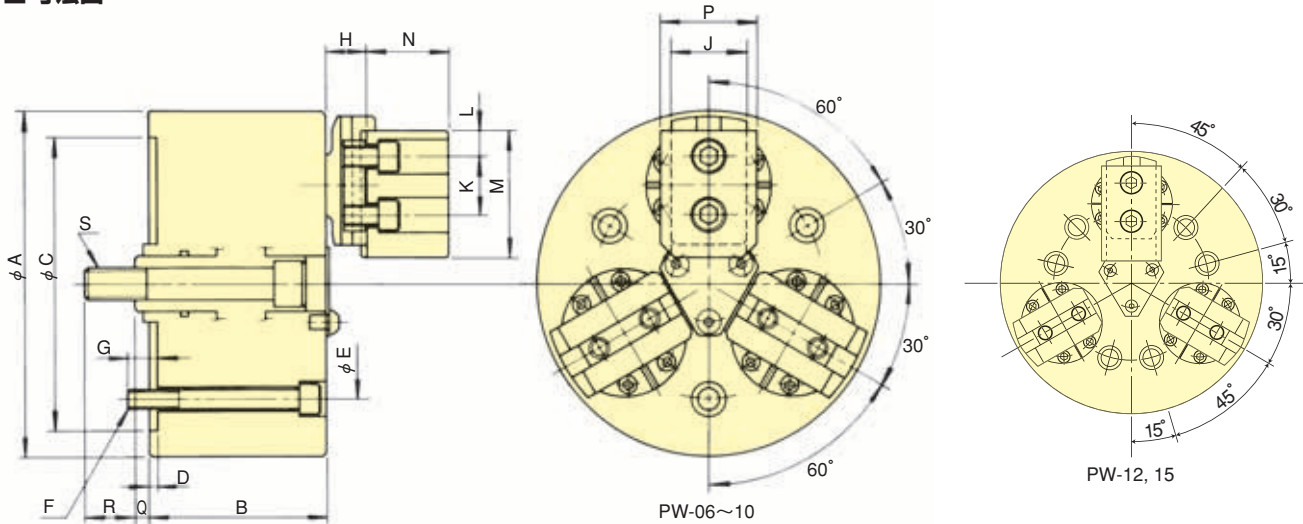

### ■ 寸法表

寸法 型式	A	B	C(H6)	D	E	F	G	H	J
PW-06	162	77	140	5	104.8	3-M10	14	19.3	38.07
PW-08	200	88	170	5	133.4	3-M12	18	23.33	44.45
PW-10	254	105	220	5	171.4	3-M16	25	29.14	57.1
PW-12	300	105	220	5	171.4	6-M16	25	29.14	57.1
PW-15	381	117	300	5	235	6-M20	30	32.4	66.62

寸法 型式	K	L	M	N	P	Q max.	Q min.	R	S
PW-06	29.36	15	67.5	47.7	50.8	24	12.6	25.4	M16
PW-08	34.14	15	74	54.17	57	29.3	15.1	29.2	M18
PW-10	44.45	19	89.5	66.9	70.1	34.9	17.4	34.7	M22
PW-12	44.45	19	108.5	66.9	70.1	34.9	17.4	34.7	M22
PW-15	53.98	23.9	140	73.2	76.2	48.7	26.3	41	M27

### 把握力性能曲線

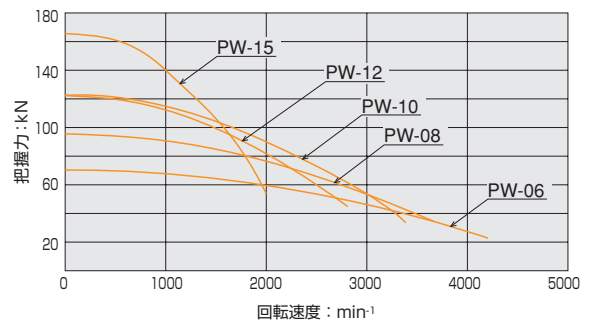

### ■ 仕様表

仕様 型式	ジョー ストローク (直径) mm	フランジ ストローク mm	許容最大入力 kN(kgf)	最大静的 把握力 kN(kgf)	許容最高 回転速度 min <sup>-1</sup>	質量 (標準ソフトジョー付) kg	慣性モーメント kg・m <sup>2</sup>	適合 シリンダ	許容最大 油圧力 MPa(kgf・cm <sup>2</sup> )	把握範囲		偏心量 PWCのみ mm
										外径 φmm	内径 φmm	
PW-06	7.9	11.4	23.3(2376)	70.0(7138)	4200	14.7	0.050	Y1225R/RE	2.30(23.5)	13~120	70~160	1.0
PW-08	9.5	14.2	32.0(3263)	96.0(9788)	3700	23.5	0.110	Y1225R/RE	3.09(31.5)	35~152	76~194	1.5
PW-10	12.7	17.5	41.0(4180)	123.0(12540)	3400	39.3	0.265	Y1530R/RE	2.80(28.5)	54~203	94~235	2.0
PW-12	12.7	17.5	41.0(4180)	123.0(12540)	2800	58.3	0.523	Y1530R/RE	2.80(28.5)	58~241	129~300	2.0
PW-15	15.8	22.4	55.0(5607)	165.0(16800)	2000	95.0	1.943	Y2035R/RE	2.14(21.8)	73~317	163~381	3.0

### ■ 作動位置寸法図 (外径把握時)

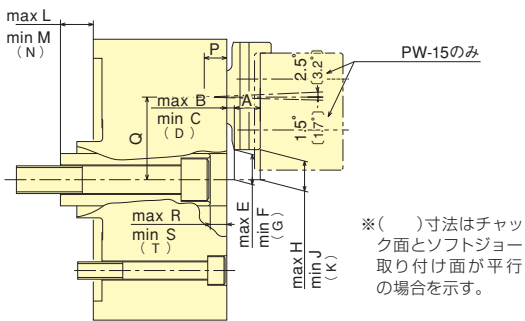

### ■ 作動位置寸法表 (外径把握時)

寸法 型式	A	B	C	D	E	F	G	H	J	K
PW-06	15.50	5.02	3.05	3.80	20.09	18.89	19.33	20.77	18.48	19.33
PW-08	18.50	5.68	3.24	4.80	22.63	21.18	22.10	23.08	20.36	22.10
PW-10	25.61	5.47	2.44	3.53	31.16	29.44	30.03	32.37	28.77	30.03
PW-12	25.61	5.47	2.44	3.53	51.81	50.09	50.68	53.02	49.42	50.68
PW-15	28.67	6.27	2.35	3.73	75.85	73.76	74.45	77.45	72.91	74.45

### ■ 作動位置寸法図 (内径把握時)

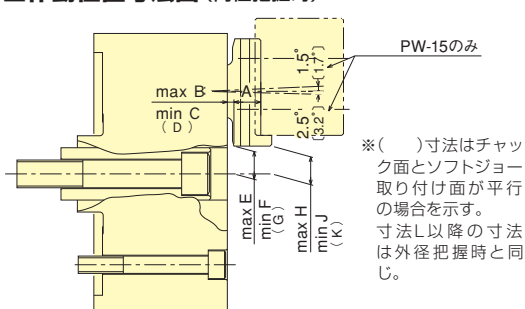

### ■ 作動位置寸法表 (内径把握時)

寸法 型式	A	B	C	D	E	F	G	H	J	K
PW-06	15.03	5.66	3.43	4.27	16.32	15.08	15.53	17.25	14.52	15.53
PW-08	16.71	8.35	5.56	6.62	18.04	16.41	17.00	18.99	15.84	17.00
PW-10	20.51	10.92	7.23	8.63	19.59	17.61	18.33	20.74	16.92	18.33
PW-12	20.51	10.92	7.23	8.63	40.24	38.26	38.98	41.39	37.57	38.98
PW-15	23.94	12.19	6.44	8.46	54.75	52.23	53.05	56.41	51.35	53.05



**CHUCK**

# Power Wing Chuck

## PW(C) series

The specification for PW-C is the compensation chuck. The jaws will follow and grip the component held by Centre and Pin. The dimensions and specification are the same as those for PW.

### Pull back of workpiece for secure gripping of casting or forging

### PWC compensating type for rough casting through centre



#### ● Powerful Gripping

After gripping the component in a radial direction, a power PULL-BACK action is applied which significantly increases the Gripping Force, allowing a heavier machine cut to be taken.

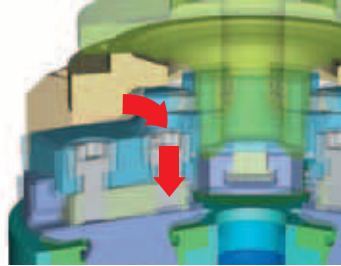

#### ● High Durability

Master jaws are of spherical design and sealed against swarf and coolant. This permits High Gripping Forces to be retained between lubrication periods.

#### ● Complete Sealing

Additional sealing at (1) and (2) reduces grease contamination and increases maintenance period.

#### ● JAW Equalising 5° max equalising angle

Various workpieces can be firmly gripped by the self-equalising jaws to max. 5°.

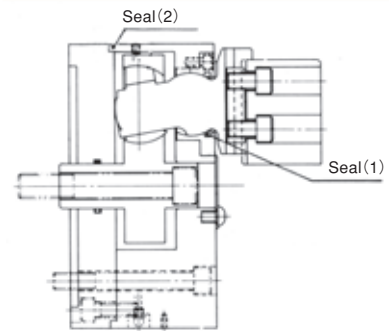
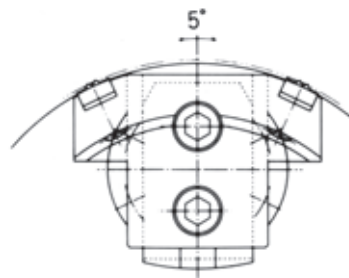

#### ● Gripping on Tapered Parts

The radial and PULL-BACK jaw action allows rough tapered castings and forgings to be securely gripped to maximum 20°.

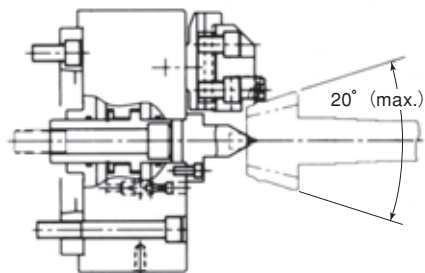

#### ■ Type of the gripping pieces

\*The type of the gripping pieces is selected according to the work conditions.

##### U-Type

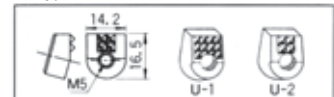

##### U-2S



##### R-Type

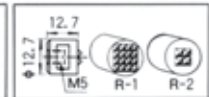

\*CE correspondence

### Work Examples

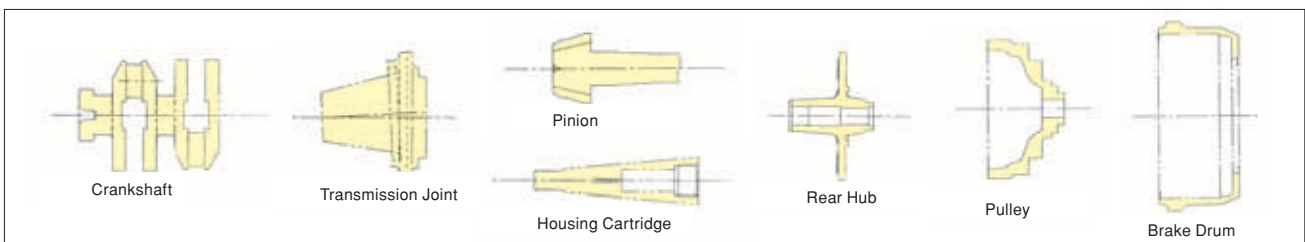

### Gripping Examples

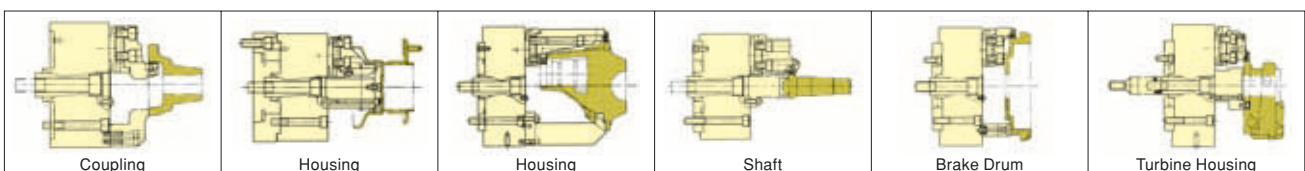

## Dimensional Drawings

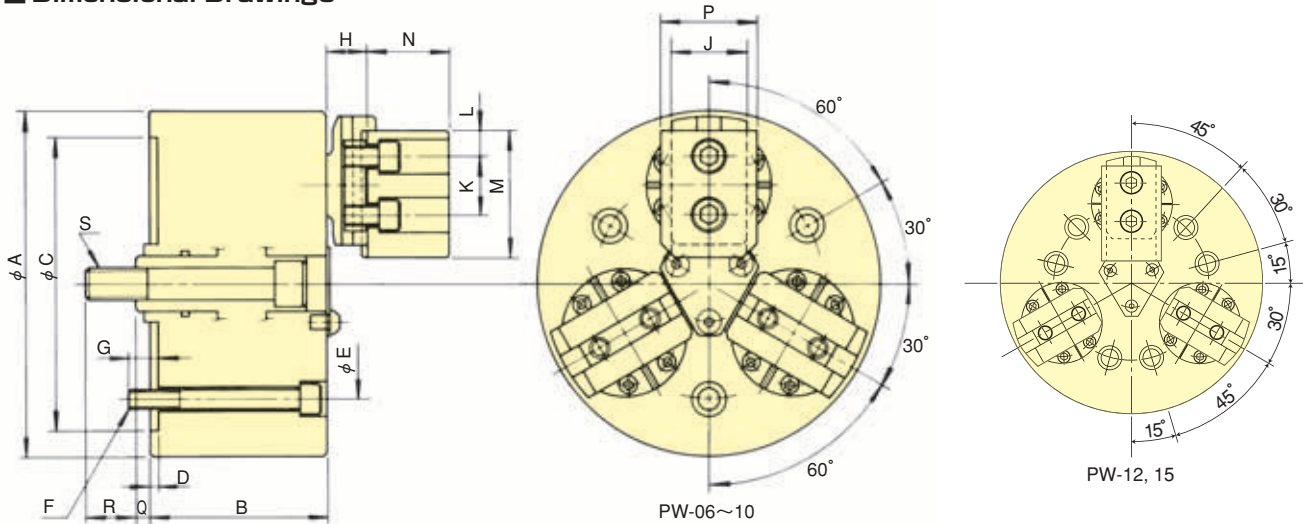

## Dimensions

Model	A	B	C(H6)	D	E	F	G	H	J
PW-06	162	77	140	5	104.8	3-M10	14	19.3	38.07
PW-08	200	88	170	5	133.4	3-M12	18	23.33	44.45
PW-10	254	105	220	5	171.4	3-M16	25	29.14	57.1
PW-12	300	105	220	5	171.4	6-M16	25	29.14	57.1
PW-15	381	117	300	5	235	6-M20	30	32.4	66.62

Model	K	L	M	N	P	Q max.	Q min.	R	S
PW-06	29.36	15	67.5	47.7	50.8	24	12.6	25.4	M16
PW-08	34.14	15	74	54.17	57	29.3	15.1	29.2	M18
PW-10	44.45	19	89.5	66.9	70.1	34.9	17.4	34.7	M22
PW-12	44.45	19	108.5	66.9	70.1	34.9	17.4	34.7	M22
PW-15	53.98	23.9	140	73.2	76.2	48.7	26.3	41	M27

## Gripping Performance

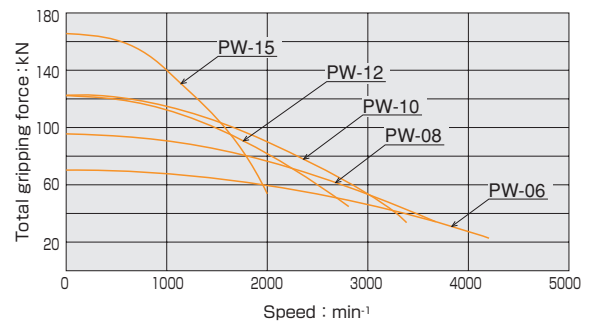

## Specifications

Model	Specs	Jaw Stroke (diameter) mm	Plunger Stroke mm	Max. Draw Bar Pull Force kN(kgf)	Max. Gripping Force kN(kgf)	Max. Speed min <sup>-1</sup>	Net Weight with Soft top jaws kg	Moment of inertia kg · m <sup>2</sup>	Matching Cylinder	Max. pressure MPa(kgf · cm <sup>2</sup> )	Gripping range		Compensation value for PWC only mm
											external φ mm	internal φ mm	
PW-06		7.9	11.4	23.3(2376)	70.0 (7138)	4200	14.7	0.050	Y1225R/RE	2.30(23.5)	13~120	70~160	1.0
PW-08		9.5	14.2	32.0(3263)	96.0 (9788)	3700	23.5	0.110	Y1225R/RE	3.09(31.5)	35~152	76~194	1.5
PW-10		12.7	17.5	41.0(4180)	123.0(12540)	3400	39.3	0.265	Y1530R/RE	2.80(28.5)	54~203	94~235	2.0
PW-12		12.7	17.5	41.0(4180)	123.0(12540)	2800	58.3	0.523	Y1530R/RE	2.80(28.5)	58~241	129~300	2.0
PW-15		15.8	22.4	55.0(5607)	165.0(16800)	2000	95.0	1.943	Y2035R/RE	2.14(21.8)	73~317	163~381	3.0

## Dimensional Drawing for actuated position (External Gripping)

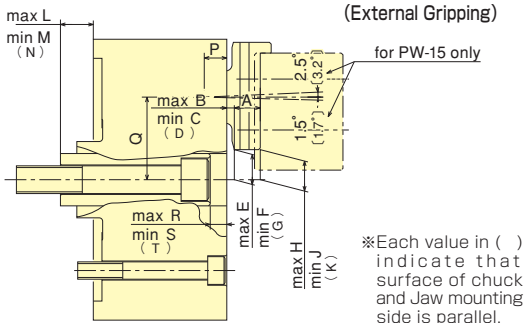

## Dimensions for actuated position (External Gripping)

Model	A	B	C	D	E	F	G	H	J	K
PW-06	15.50	5.02	3.05	3.80	20.09	18.89	19.33	20.77	18.48	19.33
PW-08	18.50	5.68	3.24	4.80	22.63	21.18	22.10	23.08	20.36	22.10
PW-10	25.61	5.47	2.44	3.53	31.16	29.44	30.03	32.37	28.77	30.03
PW-12	25.61	5.47	2.44	3.53	51.81	50.09	50.68	53.02	49.42	50.68
PW-15	28.67	6.27	2.35	3.73	75.85	73.76	74.45	77.45	72.91	74.45

## Dimensional Drawing for actuated position (Internal Gripping)

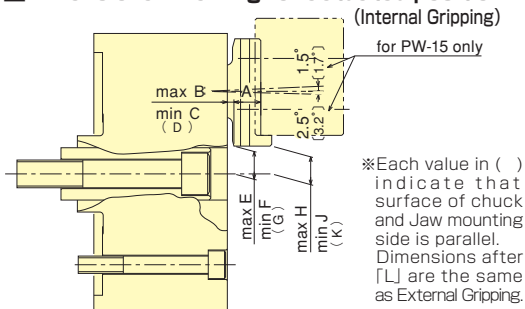

Model	L	M	N	P	Q	R	S	T
PW-06	24.0	12.6	18.95	13.20	47.63	14.60	3.20	9.55
PW-08	29.30	15.10	22.95	16.40	57.15	18.50	4.30	12.17
PW-10	34.90	17.40	27.05	19.30	71.43	19.60	2.10	11.75
PW-12	34.90	17.40	27.05	19.30	92.08	19.60	2.10	11.75
PW-15	48.70	26.30	38.40	20.07	120.65	24.90	2.50	14.60

## Dimensions for actuated position (Internal Gripping)

Model	A	B	C	D	E	F	G	H	J	K
PW-06	15.03	5.66	3.43	4.27	16.32	15.08	15.53	17.25	14.52	15.53
PW-08	16.71	8.35	5.56	6.62	18.04	16.41	17.00	18.99	15.84	17.00
PW-10	20.51	10.92	7.23	8.63	19.59	17.61	18.33	20.74	16.92	18.33
PW-12	20.51	10.92	7.23	8.63	40.24	38.26	38.98	41.39	37.57	38.98
PW-15	23.94	12.19	6.44	8.46	54.75	52.23	53.05	56.41	51.35	53.05