



ROTARY CYLINDER

中実回転油圧シリンダ Hydraulic Cylinder with Closed Centre Y-R series

中実のKITAGAWAスタンダードタイプ Closed Centre KITAGAWA standard type

- ロックバルブ、リリーフバルブ内蔵の安全構造
Built in safety check valves and pressure relief valves

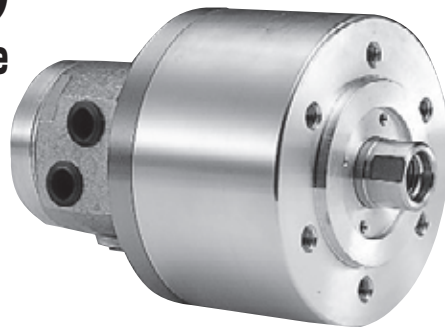

■ 寸法図 Dimensional Drawings

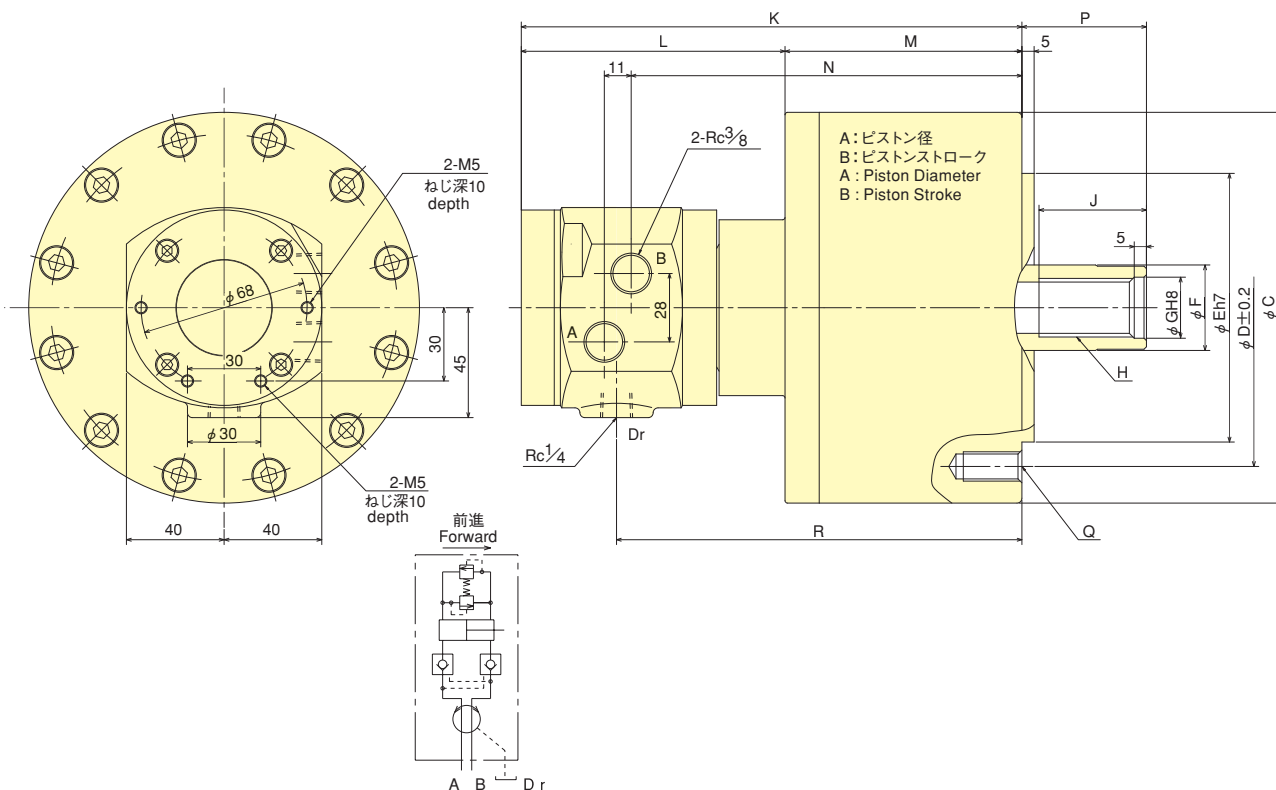

■ 寸法表 Dimensions

寸法 型式 Model	A	B	C	D	E	F	G	H	J	K	L	M	N	P max.	P min.	Q	R
Y0715R	75	15	104	90	65	30	21	M20	35	172	106	66	127	46	31	6-M 6×20	133
Y1020R	105	20	135	100	80	30	21	M20	35	197	108	89	152	45	25	6-M10×20	158
Y1225R	125	25	160	130	110	35	25	M24	44	205	108	97	160	51	26	6-M12×24	166
Y1530R	150	30	190	130	110	45	31	M30	45	214	108	106	169	56	26	12-M12×24	175
Y2035R	200	35	245	145	120	55	37	M36	60	228	106	122	183	69	34	12-M16×30	189

■ 仕様表 Specifications

※ピストン推力：油圧力4.0MPa(40.8kgf/cm²) ※ドレン量は油圧力3.0MPa(30.6kgf/cm²)、油温50℃の時
 ※Draw bar pull force : Pressure 4.0MPa (40.8kgf/cm²) ※Leakage : 4.0MPa (40.8kgf/cm²) and oil temperature 50℃.

仕様 型式 Model	ピストンストローク Piston stroke mm	ピストン表面積 Piston Area cm ²	ピストン推力 Draw bar kN(kgf)	最高使用油圧力 Max. Operation Pressure MPa(kgf/cm ²)	ドレン量 Leakage ℓ/min	許容最高回転速度 Max. Speed min ⁻¹	質量 Net Weight kg	慣性モーメント Moment of inertia kg·m ²
Y0715R	15	44	16.6 (1693)	4.0 (40.8)	0.8	6000	4.0	0.003
Y1020R	20	86	32.0 (3263)	4.0 (40.8)	0.8	6000	7.1	0.013
Y1225R	25	122	46.0 (4691)	4.0 (40.8)	0.8	6000	10.0	0.023
Y1530R	30	176	66.0 (6730)	4.0 (40.8)	0.8	5500	13.5	0.048
Y2035R	35	314	117.0 (11930)	4.0 (40.8)	0.8	5500	22.0	0.098