

INSTRUCTION MANUAL

FG-M type

Finger Chuck for Motorcycle Wheels



DANGER

- This instruction manual is for production engineers and maintenance personnel in charge of operation of this product. When a beginner uses this product, receive instructions from experienced personnel, the distributor or our company.
- Before installing, operating or maintaining this equipment, carefully read this manual and the safety labels attached to the equipment. Failure to follow these instructions and safety precautions could result in serious injury, death, or property damage.
- Store this manual near equipment for future reference.
- If any questions related to safety arise about this manual, please confirm them with the distributor or our company.

KITAGAWA IRON WORKS CO., LTD.

77-1 Motomachi, Fuchu, Hiroshima 726-8610 Japan

TEL +81-(0)847-40-0526

FAX +81-(0)847-45-8911

Preface

This manual provides detailed information about how to safely and correctly use the finger chuck for motorcycle wheels (FG-M type) for a lathe.

Before starting to use this finger chuck for motorcycle wheels, read this manual carefully and always follow the instructions and warnings in "Important Safety Precautions" and "Precautions for Use" at beginning of the manual. Failure to follow these precautions could result in a serious accident.

Terms and Symbols Used for Safety Messages

In this manual, precautions for handling that are considered especially important are classified and displayed as shown below depending on the damage of risk including the seriousness of the harm that could result. Please sufficiently understand the meanings of these terms and follow the instructions for safe operation.

Safety Alert Symbol

The triangle is the safety alert symbol used to alert you to potential safety hazards that could result in injury or death.



Indicates a hazardous situation which, if you not avoided, will result in death or serious injury.



Indicates a hazardous situation which, if you not avoided, could result in death or serious injury.



Indicates a hazardous situation which, if you not avoided, could result in minor or moderate injury.



Indicates instructions which, if not avoided, could result in damage to the equipment or a shortened work life.

Liability and How to Use this Manual

This product is suitable for gripping a motorcycle aluminum wheel on the lathes or rotary tables. This product is equipped with the levers to clamp the motorcycle aluminum wheel and they operate by means of a rotary cylinder. For any other applications, please contact us.

Our company will not assume responsibility for injury, death, damage, or loss resulting from not following the instructions in this manual.

There are countless things that cannot or should not be done, and it is impossible to cover all of them in this manual.

Therefore, do not perform any actions unless they are specifically allowed in this manual. If any questions related to safety arise about operation, control, inspection and maintenance which are not specified in this manual, please confirm them with our company or distributor before performing them.

Guarantee and Limitation of Liability

The guarantee period of this product is 1 year after delivery.

Use the parts delivered by Kitagawa Iron Works for all the parts including consumable parts. We will not assume responsibility for injury, death, damage, or loss caused by usage of parts not manufactured by Kitagawa Iron Works. Additionally, if parts other than genuine parts manufactured by Kitagawa Iron Works are used, this guarantee will be completely invalid.

The chuck and cylinder from Kitagawa Iron Works should be used together. If you must use a part not made by Kitagawa, check with us or our distributor to be sure it is safe to do so. We will not be responsible for injury, death, damage or loss caused by use of a chuck or cylinder made by another company unless this use has been approved by Kitagawa or its distributor.

Table of Contents

1. Structural Drawing and Parts List -----	4
1-1. Type display	
1-2. Structural drawing	
1-3. Scope of product	
1-4. Parts list	
2.  Important Safety Precautions -----	9
3. Specifications -----	14
3-1. Specifications	
4. Top tooling -----	15
4-1. Exchange of jaw	
4-2. Exchange of lever	
4-3. Centering jigs	
4-4. Balance pins for seating confirmation	
4-5. Floating for chattering prevention	
5. Usage -----	21
5-1. Precautions during gripping work with chuck	
5-2. Precautions related to processing	
6. Maintenance and Inspection -----	23
6-1. Periodic Inspection	
6-2. Grease lubrication	
6-3. Disassembling	
7. Malfunction and Countermeasures -----	28
7-1. In the case of malfunction	
7-2. Where to contact in the case of malfunction	

For Machine Tool Manufacturers (Chapter 8)

8. Attachment -----	30
8-1. Outline drawing of attachment	
8-2. Design of chuck open/close hydraulic circuit	
8-3. Design of seating confirmation air circuit	
8-4. Design of the draw pipe	
8-5. Attachment of chuck	
9. Other Information -----	38
9-1. About disposal	

1. Structural Drawing and Parts List

1-1. Type display

Type display as shown below

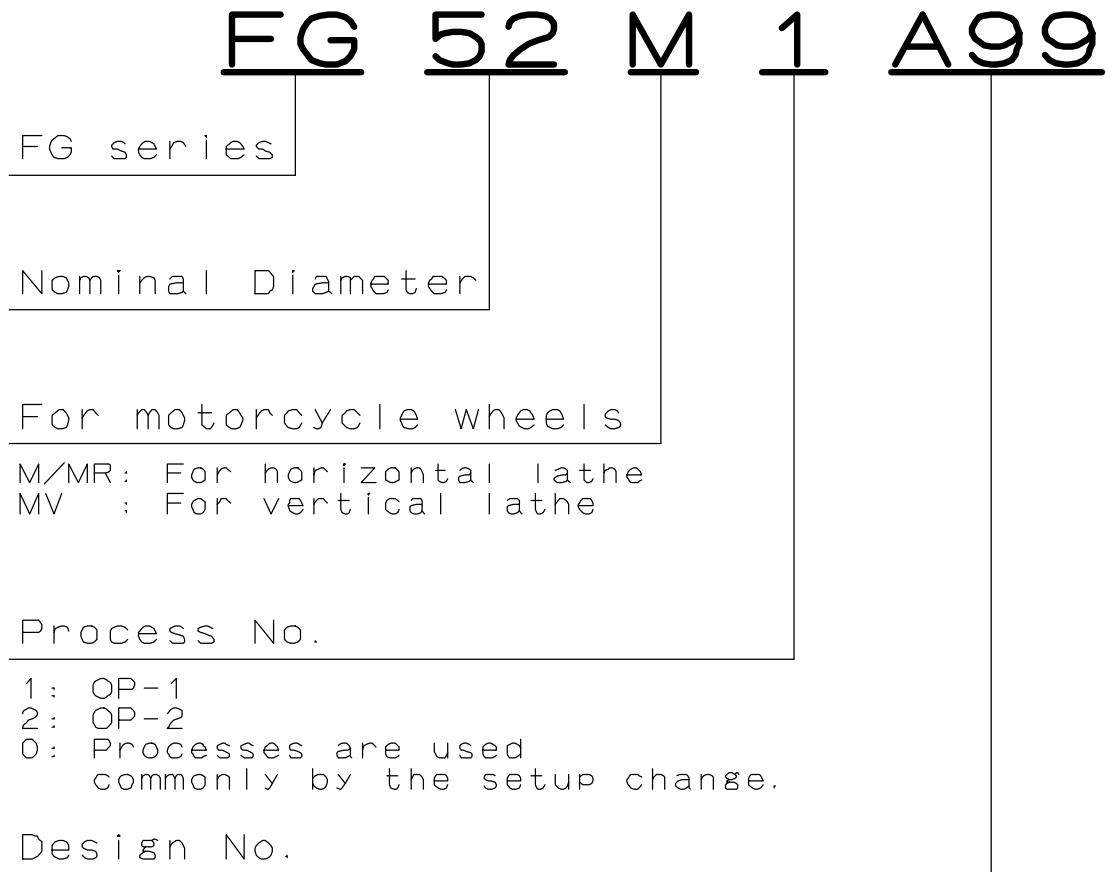

Fig.1

1-2. Structural drawing

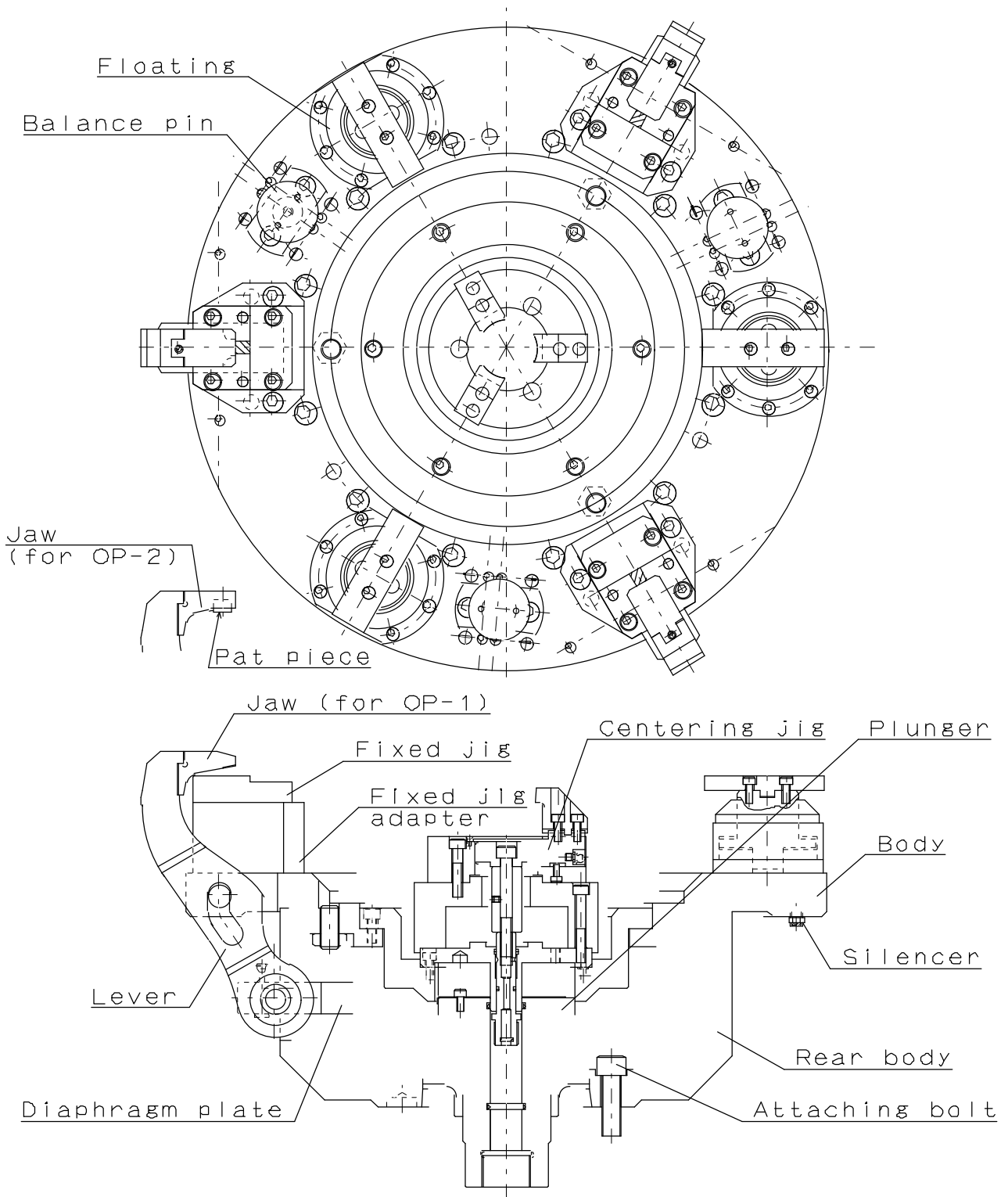

Fig.2

1-3. Scope of product

This instruction manual is for the chuck part.

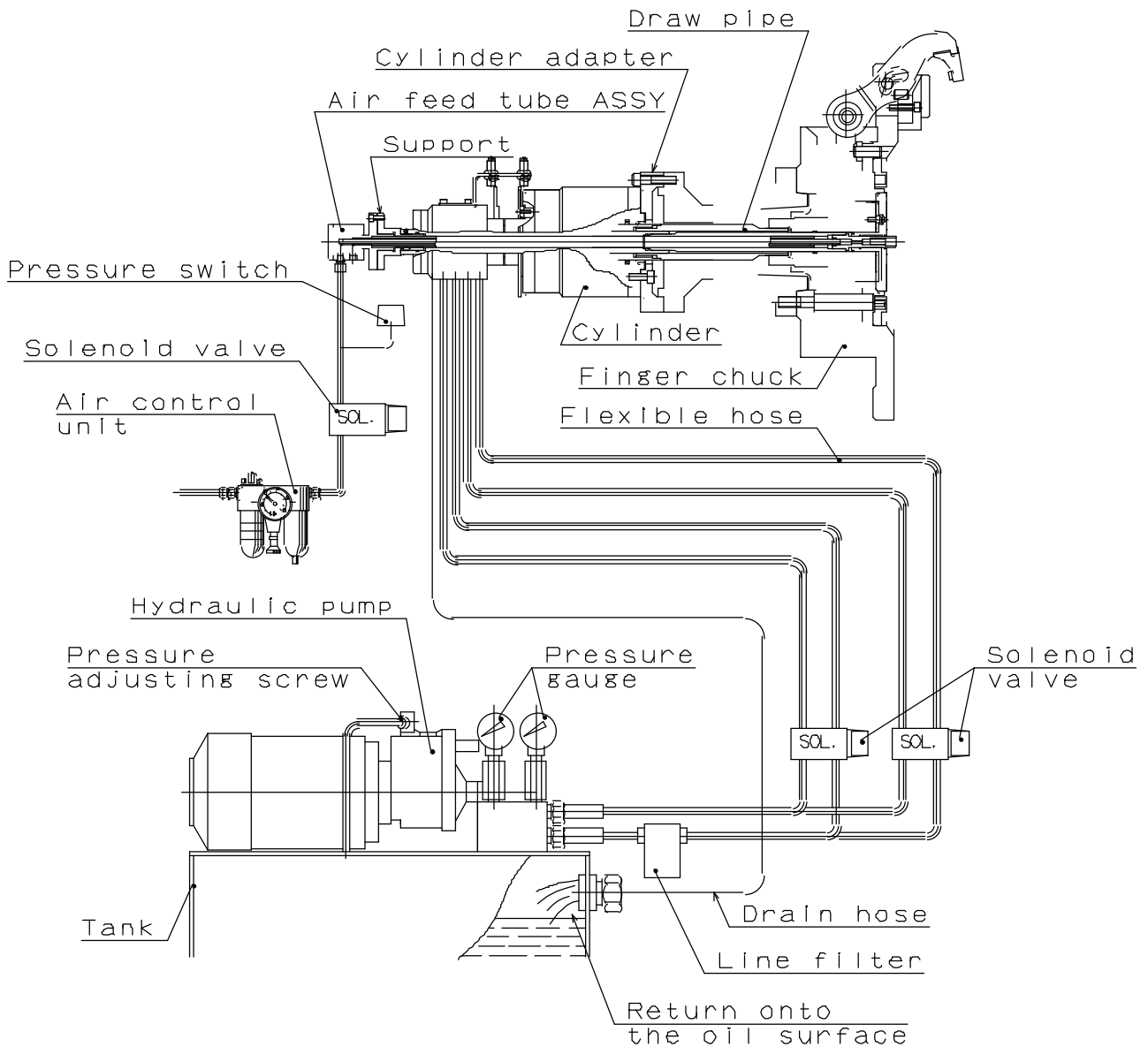

Fig.3

! WARNING

- To prevent the work from flying, safe design, maintenance and erroneous action prevention of the hydraulic system to maintain the gripping force of the chuck is extremely important. Thoroughly read the “Important Safety Precautions” on and after page 9 in this manual.
- As for the cylinder, follow the instruction manual for the cylinder.

1-4. Parts list

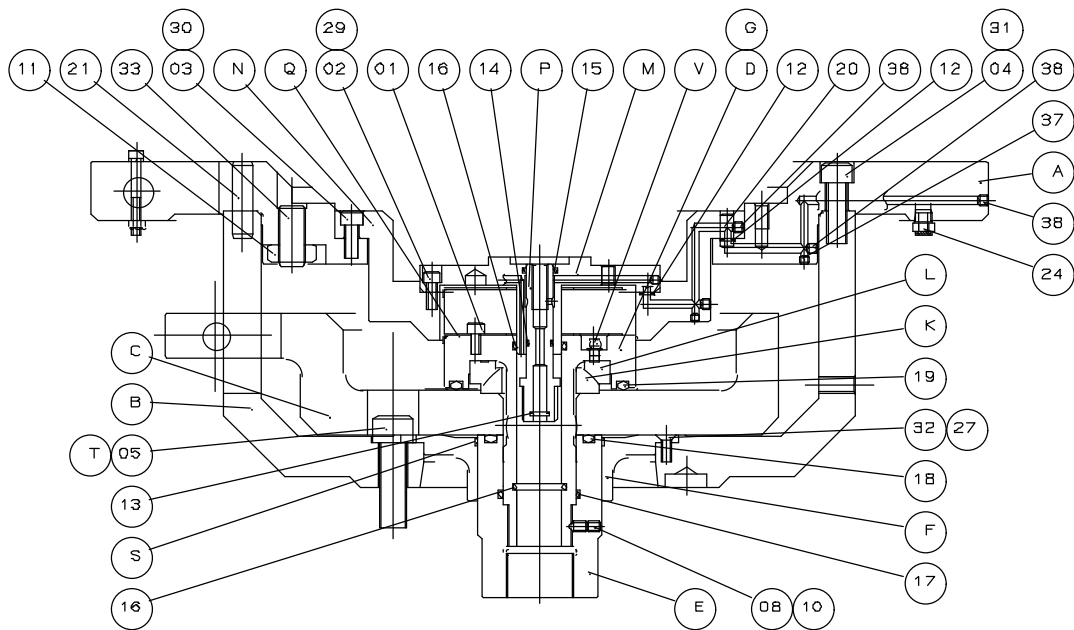
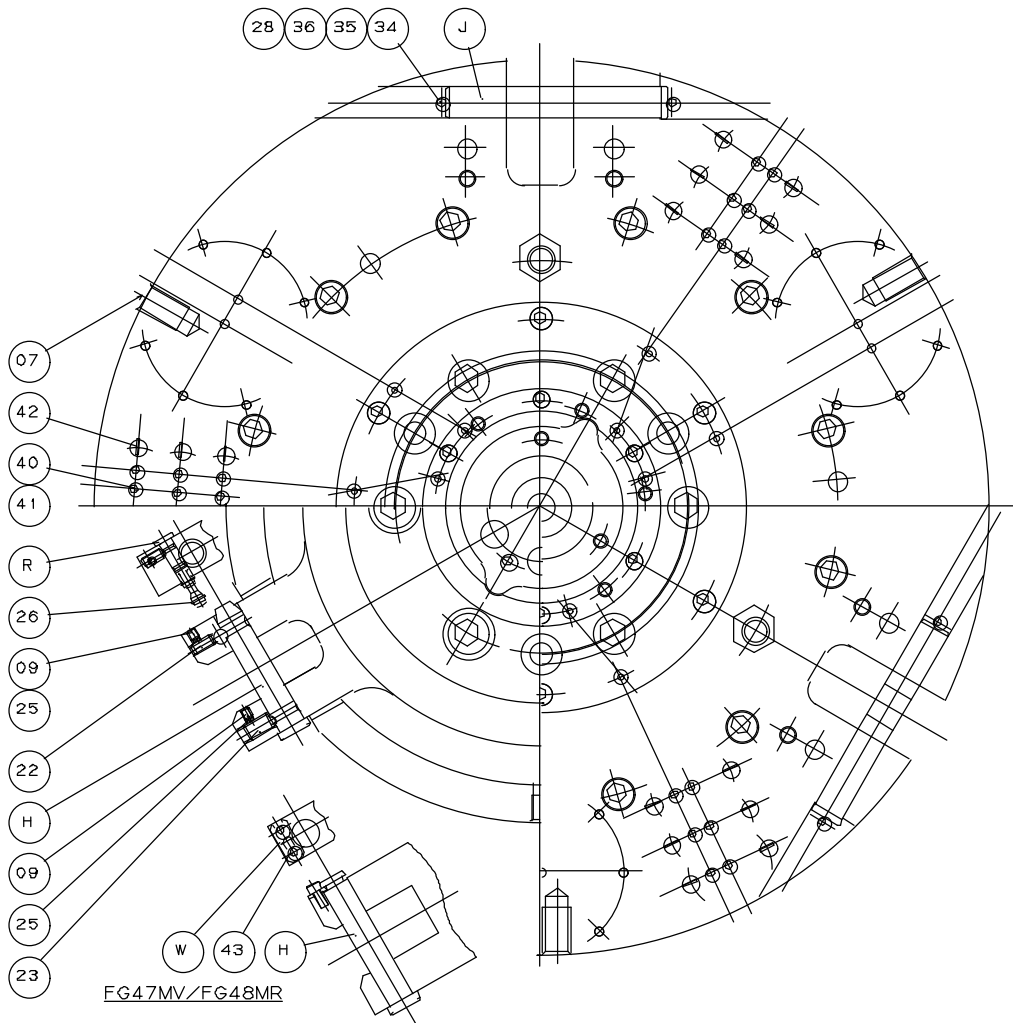

Fig.4

Table 1

No.	Part name	Quantity	No.	Part name	Quantity
A	Body	1	12	O-ring	3 or 12
B	Rear body	1	13	O-ring	1
C	Diaphragm plate	1	14	O-ring	1
D	Plunger	1	15	O-ring	1
E	Plunger nut	1	16	O-ring	1 or 2
F	Bushing A	1	17	O-ring	1
G	Connecting handle	1	18	O-ring	1
H	Pin	3	19	O-ring	1
J	Guide pin	3	20	Parallel pin	3
K	Spherical bushing A 1	1	21	Parallel pin	1
L	Spherical bushing A 2	1	22	Mini ball plunger	3
M	Plunger cover	1	23	Small plunger	3
N	Plunger cover A	1	24	Silencer	3 or 6
P	Draw tube	1	25	Fixed plate	6
Q	Key plate	1	26	Retaining ring	3
R	Lock pin	3	27	Hex key	1
S	Scraper	1	28	Hex key	1
T	Handle	1	29	Hex key	1
U	-	-	30	Hex key	1
V	Grease nipple	1	31	Hex key	1
W	Plate	3	32	Machine screw	6
			33	Set screw	3
01	Socket head cap screw	2	34	Socket head cap screw	6
02	Socket head cap screw	6	35	Spring washer	6
03	Socket head cap screw	6	36	Nut	6
04	Socket head cap screw	12	37	Set screw	-
05	Attaching bolt	6	38	Set screw	-
06	Eye bolt M10	1	39	-	-
07	Eye bolt M16	3	40	Socket head cap screw	18
08	Set screw	2	41	Seal washer	18
09	Set screw	6	42	Plug	18
10	Set screw	2	43	Socket head cap screw	6
11	Nut	3			

Refer to the Spec. information for supply for the top tooling.

Parts with mark are for FG52M / FG52MV only. Parts with mark are for FG47MV / FG48MR only. Parts with mark are for FG57M only.

2. Important Safety Precautions

Important safety precautions are summarized below. Please read this section before first starting to use this product.



DANGER

Failure to follow the safety precautions below will result in serious injury or death.



Turn off main power supply before attaching, inspecting or replacing chuck, and before adding oil.

For All Users

- The chuck may start rotation suddenly, and a part of the body or clothing may be caught.

Main power supply

OFF

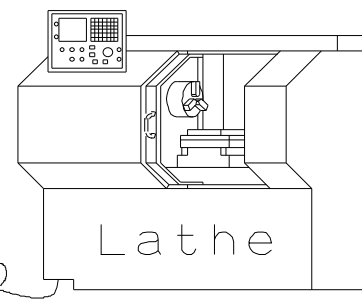
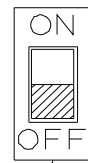

Close door before rotating spindle.

For All Users

- If the door is not closed, you may touch the rotating chuck or the work may fly out, which is very dangerous. (In general, the safety interlock function which allows rotation only when the door is the manual mode or the test mode)

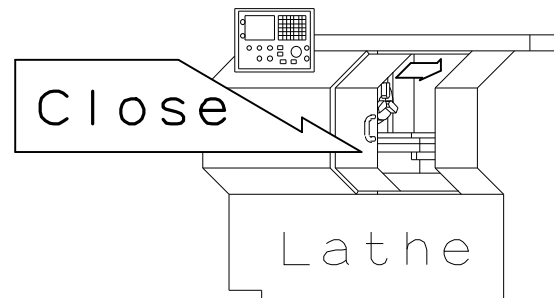

During spindle rotation, do not turn off hydraulic pump power supply and do not operate switching valve.

For All Users

- Cutting off hydraulic pressure causes a drop in the gripping force which could result in the work being released and flying out.
- Operating the manual switching valve or solenoid valve will lead to a drop of hydraulic pressure.



Important Safety Precautions



DANGER

Failure to follow the safety precautions below will result in serious injury or death.



Do not allow the rotation speed of the chuck to exceed the maximum allowable speed limit. (Refer to the Spec. information for supply and Page 14)

For All Users

- If the rotation speed of the chuck exceeds the rotation speed limit, this is very dangerous as the chuck and work will fly out. Be sure to refer to the specifications given in the Delivery Specification since the rotary speed may have to be reduced than standard value depending on the top tooling.



The input force of the chuck (piston thrust, pulling force of the draw pipe) must not exceed the allowable maximum input force. (Refer to the Spec. information for supply and Page 14)

For All Users

- Input must match the specification of the chuck.
- Adjust the hydraulic pressure to the cylinder so that the input force, which determines the gripping force of the chuck, does not exceed.
- Excessive input force can lead to breakage of the jaw attaching bolt, which is very dangerous, as the work can be damaged and fly out. Particularly for long jaws, the moment applied to the bolts becomes large, requiring the input to be reduced than standard value. Accordingly, be sure to refer to the specifications given in the Delivery Specification.



Determine the gripping force required for processing by the machine tool manufacturer or user, and check that the required gripping force is provided before processing.

For All Users

- Adjust the hydraulic pressure to the cylinder to obtain the required gripping force. If the gripping force is insufficient, this is dangerous as the work will fly out.



Variations in height of workpiece gripping part must not exceed the fluctuations of diaphragm plate. Also, do not grip the workpiece at a burred portion or in the inclined state.

For All Users

- If variations at three places in height of workpiece gripping part exceed the fluctuations of diaphragm plate, the workpiece cannot be gripped completely, causing the workpiece to fly out.
- If the burred part of workpiece or the inclined workpiece is gripped, a gripping failure will occur, causing the workpiece to fly out.



Important Safety Precautions



DANGER

Failure to follow the safety precautions below will result in serious injury or death.



Always tighten the bolts at the specified torque. If the torque is insufficient or excessive, the bolt will break, which is dangerous as the chuck or work will fly out. Use the bolts attached to the chuck, and do not use bolts other than these.

For All Users

- If the torque is insufficient or excessive, the bolt will break, which is dangerous as the chuck or work will fly out.
- Fix the lathe spindle or the chuck when you tighten bolts. Your hand could slip and get injury when you work without fixing the spindle.
- You cannot control the torque by a hex key. You must use a torque wrench for torque control.

Specified torque for socket head cap screw

Bolt size	Tightening torque	
M5	7.5	N·m
M6	13	N·m
M8	33	N·m
M10	73	N·m
M12	107	N·m
M14	171	N·m
M16	250	N·m
M20	402	N·m

Tightening torque

$$\begin{aligned}
 T &= F \times L \\
 &= 127 \times 0.1 \\
 &= 12.7 \text{ (N} \cdot \text{m)}
 \end{aligned}$$

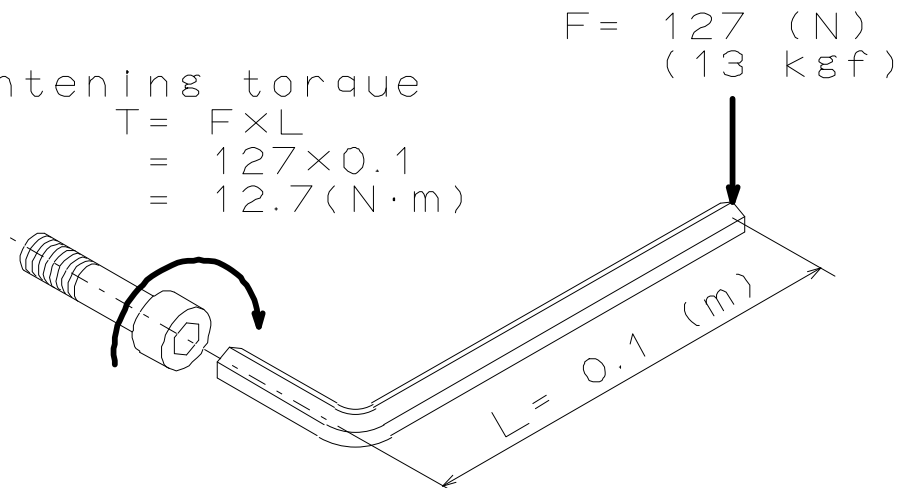

- Tightening torque is moment of force when you tighten a bolt. Tightening torque = $F \times L$.



Important Safety Precautions



DANGER

Failure to follow the safety precautions below will result in serious injury or death.



- Provide sufficient strength for the draw pipe.
- Provide sufficient screw depth for the draw pipe.
- Firmly tighten the draw pipe.

For Machine Tool Manufacturers

- If the draw pipe break, the gripping force is instantly lost and this is dangerous as work will fly out.
- If the screw depth of the draw pipe is insufficient, the screw will break and the gripping force will be lost instantly, and this is dangerous as work will fly out.
- If the engagement of the screw of the draw pipe is loose, vibration may occur resulting in breakage of the screw. If the screw breaks, the gripping force will be lost instantly, which is dangerous as the work will fly out.
- If the draw pipe is unbalanced, vibration occurs, the screw is broken and the gripping force will be lost instantly, which is dangerous as the work will fly out.



- Use a cylinder with a lock valve (safety valve, check valve) incorporated in case of sudden hydraulic pressure drop due to blackout, malfunction of the hydraulic pump, etc. Further, use a solenoid valve with a circuit that retains the gripping position when no current is carried.

For Machine Tool Manufacturers

- If the hydraulic pressure suddenly drops due to blackout or malfunction of the hydraulic pump, etc., this is dangerous as work will fly out.
- Lock valve retains the hydraulic pressure inside the cylinder temporarily, when the hydraulic pressure suddenly drops due to blackout or malfunction of the hydraulic pump, etc.

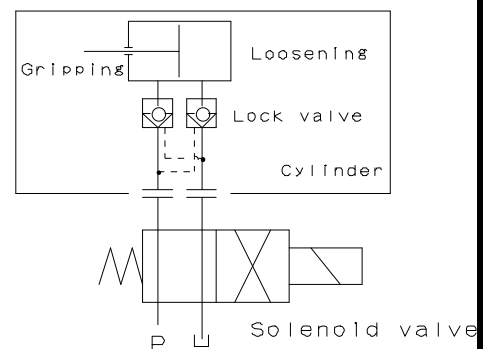
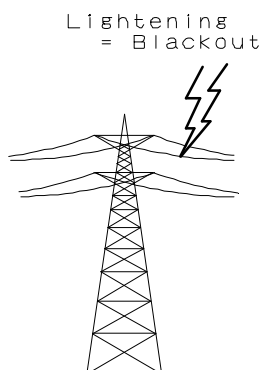

The gripping position must be retained.



Important Safety Precautions



WARNING

Failure to follow the safety precautions below could result in serious injury or death.



Do not modify the chuck.

For All Users

- Not only the chuck is damaged but also the chuck and workpiece may fly out.
- Do not install parts other than genuine parts made by Kitagawa by adding the tapping.
- Do not remove chuck parts from the chuck.



Periodically supply adequate grease (Refer to page 24). Turn off power before adding grease.

For All Users

- Insufficient grease supply lowers the gripping force, causes operation failure due to lower hydraulic pressure, lowers the gripping precision, and causes abnormal wearing and seizing, etc. This is dangerous as the work could fly out.



Do not operate the machine after drinking alcohol or taking medication.

For All Users

- Dangerous since these lead to operation mistakes and misjudgment.

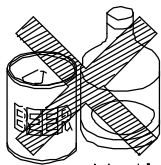

Alcohol

Medication



Do not operate the machine wearing gloves, a necktie, and other loose clothing or jewelry.

For All Users

- Dangerous since it will be caught.

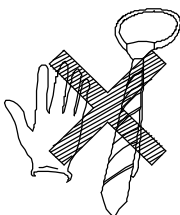

3. Specifications

3-1. Specifications

Table 2

Type		FG47MV	FG48MR	FG52M	FG52MV	FG57M
Jaw stroke	mm	27	27	27	27	27
Gripping force per a jaw	kN (kgf)	6.5 (663)	3.5 (357)	6.5 (663)	6.5 (663)	6.5 (663)
Allowable maximum input force	kN (kgf)	21 (2141)	12 (1224)	21 (2141)	21 (2141)	21 (2141)
Allowable maximum rotation speed	min ⁻¹	2500	1500	2500	2500	2000
Mass	kg	91	91	130	130	160
Moment of inertia	kg·m ²	1.78	1.78	3.65	3.65	7.10
Matching cylinder		YG-204	YG-204	YG-204	YG-204	YG-204
Maximum hydraulic pressure (with matching cylinder)	MPa (kgf / cm ²)	2.88 (29.3)	1.75 (17.3)	2.88 (29.3)	2.88 (29.3)	2.88 (29.3)
Fluctuation of diaphragm plate	mm	1.4	1.4	1.6	1.6	1.8
Balance quality (standard soft jaw not included)		G6.3				
Storing temperature / Operating temperature		-20 ~ +50 °C / -10 ~ +40 °C				

Reference: 1kN = 101.97kgf 1MPa = 10.197kgf/cm²

When storing this product, the product should be subjected to the antirust treatment and stored in a place free from wetting, condensation, or freeze.



- Allowable maximum rotary speed and allowable maximum hydraulic pressure may be different depending on the size of top tooling and workpieces. Be sure to refer to the latest Delivery Specification to use the chuck within the given specifications. Excessive hydraulic pressure or rotary speed will damage the chuck, causing the chuck and workpiece to fly out.

4. Top tooling

4-1. Exchange of jaw

Removing the jaws

1. Loosen the set screw [1].
2. Loosen the socket head cap screw [2] and remove the jaw [3]. Save the fixed plate [4] carefully.

Installing the jaws

1. Install the jaw [3] with the socket head cap screw [2]. At this time, the reference surfaces of jaws and lever must contact completely. Also, tighten the socket head cap screw with the specified torque.
2. Confirm that the fixed plate [4] is present, and then tighten the set screw [1].

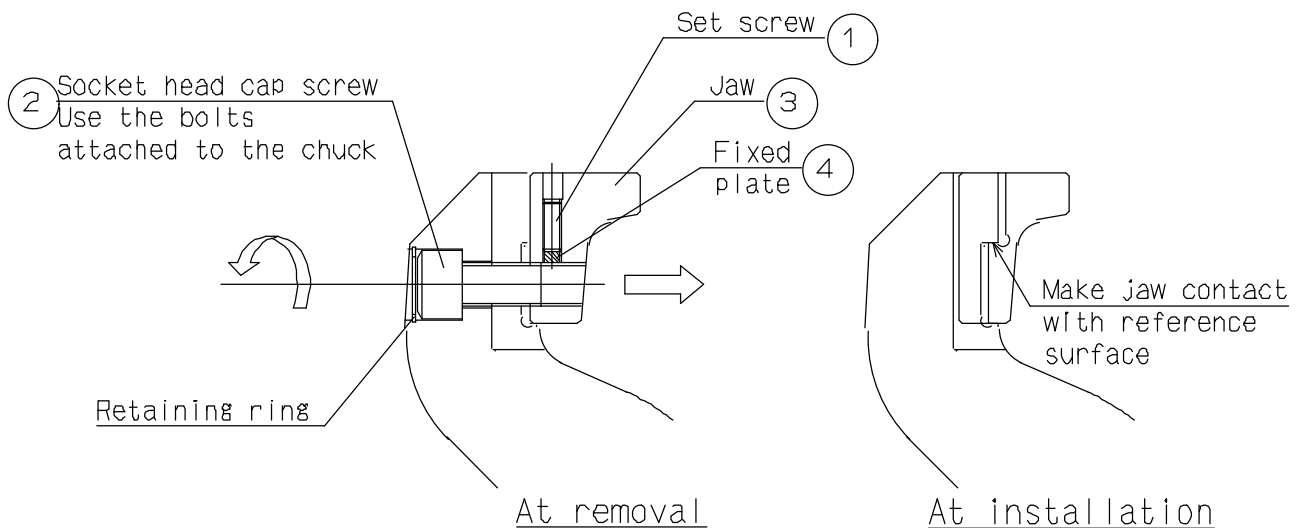

Fig.5

! DANGER

- Always tighten the bolts at the specified torque. If the torque is insufficient or excessive, the bolt will break, which is dangerous as the chuck or work will fly out.
- Use the bolts attached to the chuck, and do not use other bolts. However, if you must use other bolts not provided by Kitagawa, use bolts that have at least a strength classification of 12.9 (10.9 for M22 or more) and be sure they are long enough.

Table 3

Bolt size	Tightening torque	
M10	73	N·m
M14	171	N·m

4-2. Exchange of lever

1. FG47MV, FG48MR

Removing the lever

1. Remove the socket head cap screw [1]. Save the spring washer [3] and the nut [4] carefully.
2. Pull out guide pin [2].
3. Loosen the socket head cap screw [5] and slide the plate [6] as shown in Fig.6.
4. Pull out the pin [7] and remove the lever [8].

Installing the lever

1. Install the lever [8] with the pin [7].
2. Insert the plate into the groove of pin [7] and tighten the socket head cap screw [5] so that the pin [7] is not removed.
3. Install the lever with the guide pin [2].
4. Attach the socket head cap screw [1] and spring washer [3], and lock them with the nut [4].

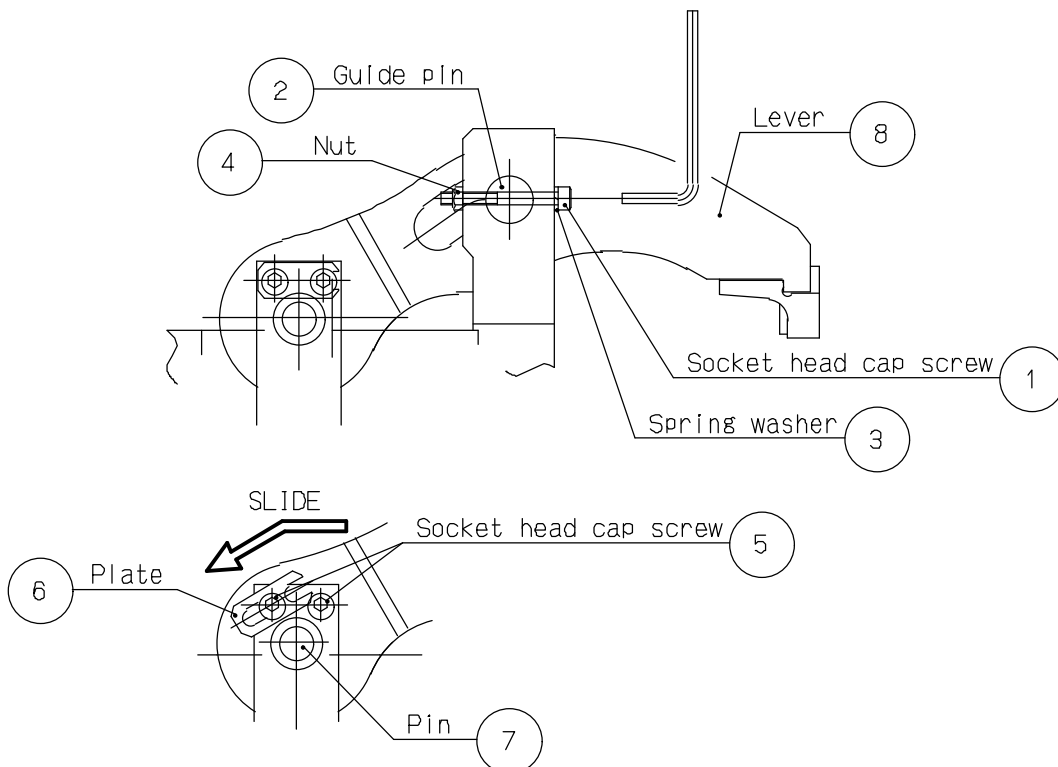

Fig.6

2. FG52M, FG52MV, FG57M

Removing the lever

1. Remove the socket head cap screw [1]. Save the spring washer [3] and the nut [4] carefully.
2. Pull out guide pin [2].
3. Push in the lock pin [5] and pull out the pin [6] and remove the lever [7].

Installing the lever

1. Install the lever [7] with the pin [6].
2. Push up the lock pin [5] so that the pin [6] is not removed.
3. Install the lever with the guide pin [2].
4. Attach the socket head cap screw [1] and spring washer [3], and lock them with the nut [4].

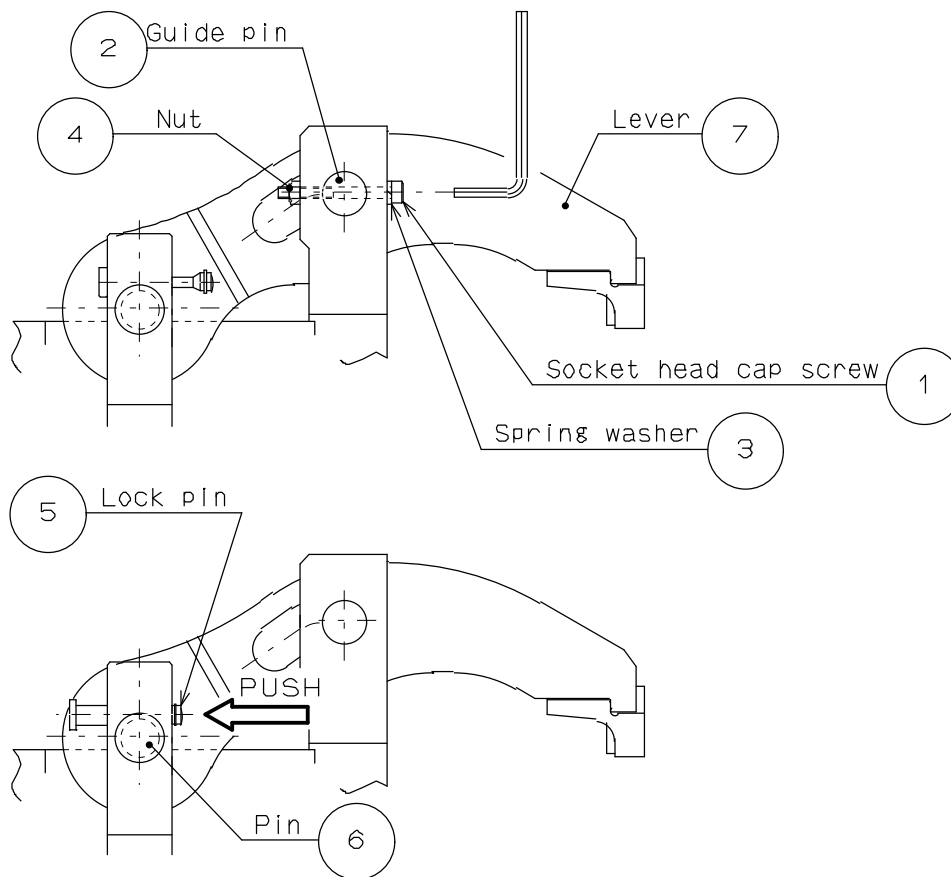
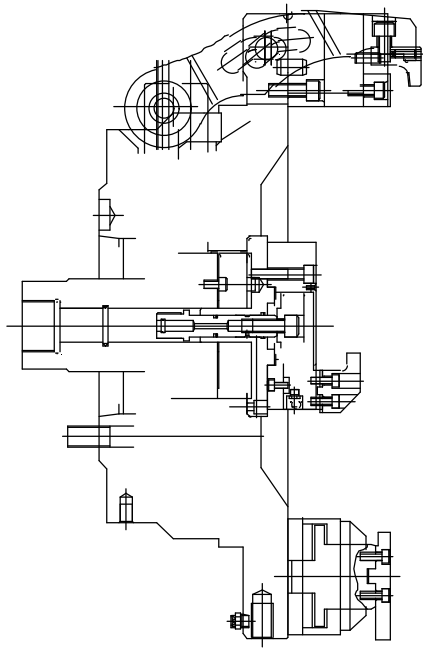

Fig.7

4-3. Centering jigs

Function of centering jigs

The centering jigs for workpiece is provided. They are the centering chuck for process-1 or the centering collet chuck for process-2 as shown in Fig.8. Refer to the Spec. information for supply for the shape and specifications.



Centering chuck

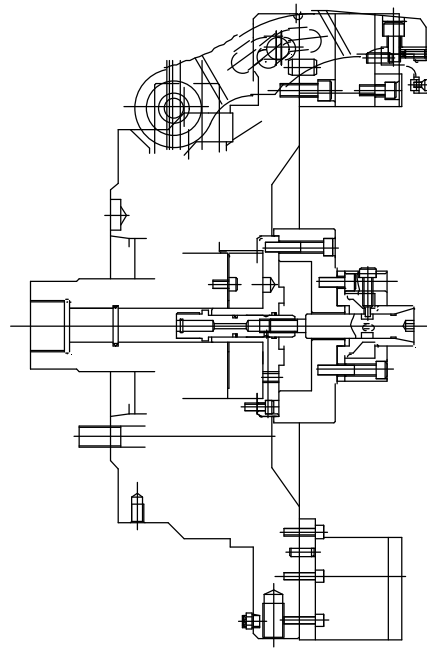

Centering Collet Chuck

Fig.8

NOTICE

- Do not operate the collet chuck without the work-piece or the master ring. This may cause the collet to be damaged.

4-4. Balance pins for seating confirmation

Function of balance pin

For the FG52M, FG52MV and FG57M chucks, the balance pins for seating confirmation can be provided at three places of chuck surface.

As shown in Fig.9, in no-load state, the balance pins are located in the upper position by the built-in springs and the air supplied into the balance pins is exhausted outside the chuck via the silencers. If a workpiece is gripped, the balance pins lower and the air circuit is closed and the air pressure rises. This pressure variation is detected by the pressure switch on the machine side.

If even one balance pin among three places is out of the workpiece, the air pressure does not rise.

Since general balance pins cover two or more workpiece sizes, the installation position can be changed. Refer to the Spec. information for supply for the shape and specifications.

The pressure switch will always become detected state if the balance pins remain in the lower position due to the spring damage or sticking of chips or if the air is not exhausted outside the chuck due to the clogged silencers. Check the balance pins periodically and repair or replace as necessary.

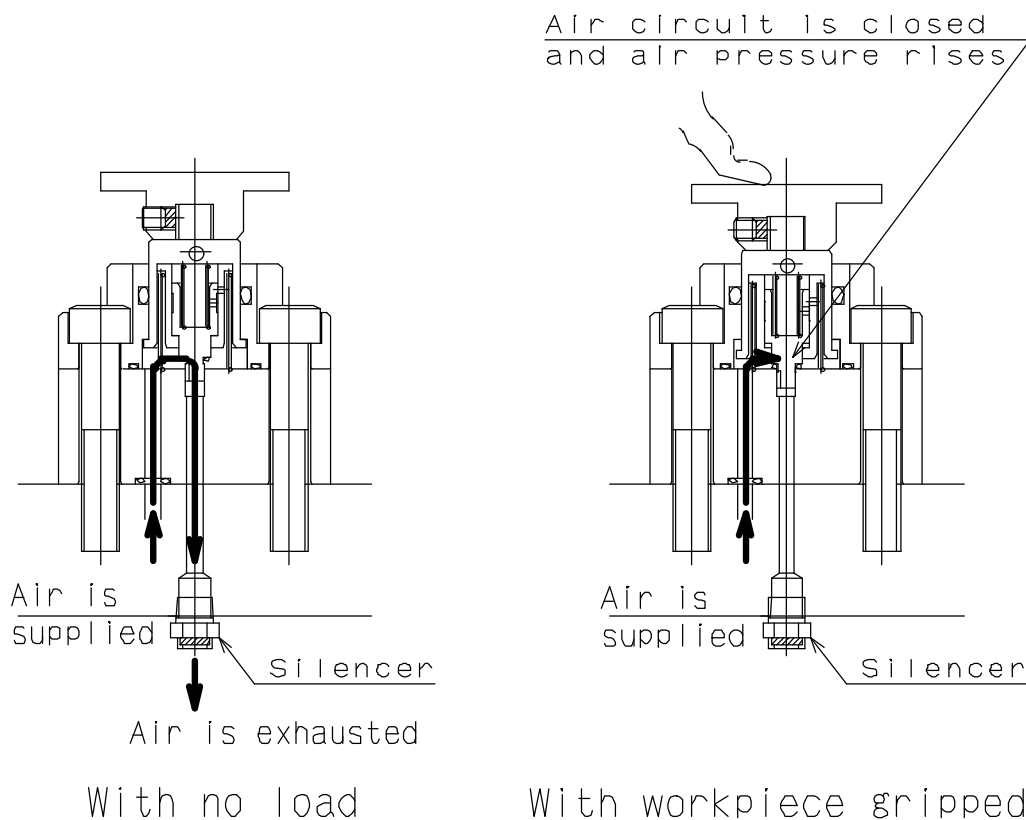

Fig.9

4-5. Floating for chattering prevention

Function of floating

The floating for chattering prevention is provided at three places of the process-1 chuck surface.

As shown in Fig.10, in no-load state, the floating is in the lower position by the built-in spring, and when the air is supplied, the floating moves up to support the workpiece. If the air pressure is raised excessively, its thrust force could deform the workpiece. Accordingly, appropriate air pressure must be obtained by a test cutting. Refer to the proper Spec. information for supply for the shape and specifications.

In the process 2, the machined surface in process 1 is used as the reference surface, and therefore normally, the fixed support is provided instead of floating.

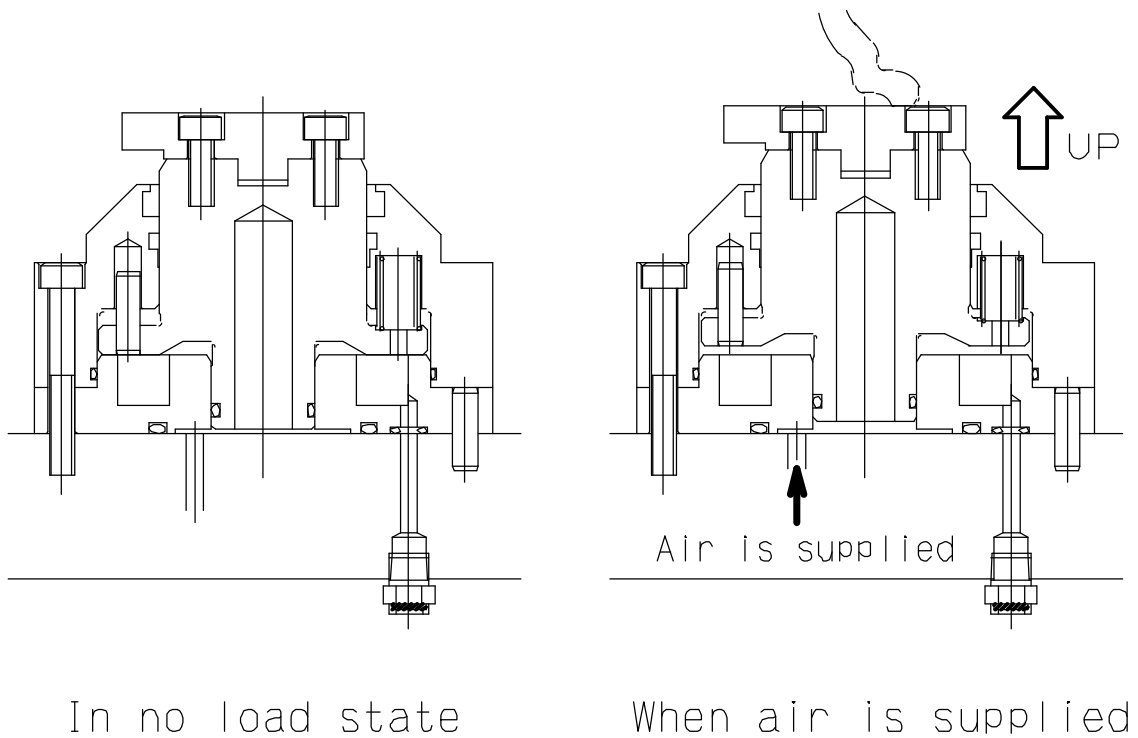

Fig.10

5. Usage

This product is a device to fix a motorcycle aluminum wheel when it is processed by the lathe machine or the rotary table.

The rotary cylinder closes the levers and fixes a motorcycle aluminum wheel so that it does not move during processing. The chuck opens the lever after having processed it and remove a wheel.

5-1. Precautions during gripping work with chuck



- This chuck is intended for motorcycle aluminum wheel machining, and it must not be used for workpieces other than motorcycle wheels. Otherwise, the workpiece may fly out.
- When gripping a work with the chuck, do not get fingers or hands become caught. This could cause crushed or cut fingers and hands.
- If variations at three places in height of workpiece gripping part exceed the fluctuations of diaphragm plate, the workpiece cannot be gripped completely, causing the workpiece to fly out. Also, if the burred part of workpiece or the inclined workpiece is gripped, a gripping failure will occur, causing the workpiece to fly out.

5-2. Precautions related to processing



<1> Unbalance

- In the case of processing largely unbalanced work, lower the rotation speed. The work will fly out and this is dangerous.
- Vibrations are generated if there is unbalance owing to the work or the jig, etc. Vibration not only will impart a negative influence on the process precision but also the endurance of the chuck being remarkably shortened, and the chuck may break. Correct the unbalance using balance weights, etc., or lower the rotation speed for use.
- Heavy cutting at high rotation speed easily generates vibration in the same manner as chuck unbalance, therefore, set cutting conditions appropriate for the dynamic gripping force and machine rigidity.

<2> Interference, contact, impact

- Before starting work, check that the levers, fixed jigs, work, etc., and the tool and the tool post, etc., do not interfere at low rotation and then start processing.
- Do not allow anything to impact the chuck, lever, and the work. The chuck will break and this is dangerous as the chuck and work will fly out.
- If the tool and the tool post contact the chuck or the work due to malfunction or tape mistake, etc., and impact is given, immediately stop the rotation, and check that there are no abnormalities in the body, lever, diaphragm plate and bolts of each part, etc.

<3> Coolant

- Unless coolant with a rust preventive effect is used, rust will occur inside the chuck and gripping force drop may result. The work will fly out due to the gripping force drop and this is dangerous.

6. Maintenance and Inspection

6-1. Periodic Inspection

Daily check

- Remove chips from the guide groove of the lever.
- Check that the balance pins and floating move over their stroke normally. If not smooth or if they do not move, disassemble and clean the chuck.
- Replace the pad pieces when worn out.
- If the centering chuck (centering jig in process 1) is used, supply grease from the grease nipple on the side surface. Also, check that the specified stroke is obtained. In case of a short stroke, not smooth motion, or no movement at all, disassemble and clean the chuck.
- Supply oil to the lubricator installed in the air piping system so as to maintain proper oil level range. Use the turbine oil class 1 additive free (ISO VG32).
- Check for water in the air filter of the air unit and drain it periodically, which otherwise causes rust.

Monthly check

- With a workpiece not gripped, check if the air is exhausted from the silencer for balance pin. If the seating pressure rises even though the workpiece is not gripped, the silencer may be clogged. Replace the silencer.

3-month check

- Check if the specified stroke is obtained when the chuck is moved over the stroke. Remove the centering jig in the center of chuck and check the stroke at the top surface of the plunger. If the stroke is short, chips may accumulate inside the lever or chuck, or chuck internal parts may be damaged. Disassemble and clean the chuck.
- Check if the chuck mounting bolts and jaw mounting bolts are loose.
- Supply grease from the grease nipple on the top surface of the plunger.

Check every 6 months or 100-thousand strokes

- Disassemble the chuck main body or balance pin assembly, floating assembly, etc. to check respective parts for a crack or damage using the color check, and repair or replace as necessary. Also, replace the O-rings and seals as necessary.

6-2. Grease lubrication

1. Position to lubricate

- Body periphery part of centering chuck (Centering jig for process-1)
- Plunger top surface

2. Grease to use

- Use the designated grease specified in Table 4. If grease other than the designated grease is used, sufficient effect may not be obtained.

Table 4

Genuine product	CHUCK GREASE PRO	Kitagawa genuine product (Kitagawa distributor of each country)
Conventional product	Kitagawa chuck grease	Conventional product
	Molykote EP Grease	TORAY Dow Corning (only inside Japan)
	Chuck EEZ grease	Kitagawa-Northtech Inc. (North American region)
	MOLYKOTE TP-42	Dow Corning (Europe, Asian region)
	Klüberpaste ME31-52	Klüber lubrication (worldwide)

3. Frequency of lubrication

Supply grease to the grease nipple on the top surface of the plunger every 3 months. For other grease nipples, supply grease every day.

4. Safety information about grease and anti-rust oil

Applicable range

- Designated grease
- Antirust agent applied to the product at the delivery.

First aid measures

After inhalation: Remove victim to fresh air. If symptoms persist, call a physician.

After contact with skin: Wash off with mild cleaners and plenty of water. If symptoms persist, call a physician.

After contact with eyes: Rinse with plenty of water. If symptoms persist, call a physician.

After ingestion: If large amounts are swallowed, do not induce vomiting. Obtain medical attention.

- Please refer to each MSDS about the grease and the anti-rust oil which you prepared.

6-3. Disassembling

Disassembling procedures

Read the following disassembling procedures with reference to page 7.

1. Before start of work, be sure to turn off the main power of the machine. Also, start work with the pistons located in the forward end position.
2. Remove the levers, balance pins, floating, and centering jig in advance.
3. Loosen the socket head cap screw [02] and remove plunger cover [M].
4. For the FG52M, FG52MV and FG57M, remove the socket head cap screws [03] and then the plunger cover A [N].
5. Loosen the socket head cap screw [01] and remove the key plate [Q].
6. Remove the socket head cap screw [04].
7. Lift up the body [A] with an eyebolt M16 [07] and remove it while hitting the back side with a plastic hammer.
8. Install the connecting handle [G] to the plunger [D] with the socket head cap screw [01].
9. Rotating the connecting handle [G], remove the diaphragm plate [C] together with the plunger [D].
10. Clean respective parts and check for a crack or damage.

CAUTION

- Use an eyebolt when attaching and detaching the chuck to and from the machine, as there is a danger of injury or damage if the chuck drops.

WARNING

- Remove the eyebolt without fail after using. If the chuck is rotated with the eyebolt, etc., attached, they may fly out and this is dangerous.
- Disassemble and clean the chuck at least once every 6 months or every 100,000 strokes (once every 2 months or more for cutting cast metal). If cutting powder or other substances stagnate inside the chuck, it will lead to insufficient stroke and a drop in the gripping force, and this is dangerous as the work will fly out. Check each part carefully and replace any part that is worn or cracked.
- After inspection, apply sufficient grease in the designated areas and reassemble.
- If you stop the machine for a long period of time, remove the work from the machine. If you don't, the work can drop due to a drop in the hydraulic pressure or the cylinder can stop or malfunction.
- If you stop the machine or store the chuck for a long period of time, add grease to prevent rust.

Assembling procedures

Read the following assembling procedures with reference to page 7.

1. Before start of work, be sure to turn off the main power of the machine. Also, start work with the pistons located in the forward end position.
2. Install the connecting handle [G] to the plunger [D] with the socket head cap screw [01].
3. Rotating the connecting handle [G], tighten the plunger [D] together with the diaphragm plate [C] into the draw-pipe.
4. Install the body [A] with the socket head cap screws [04]. Adjust so that the runout of diameter is less than 0.02 mm T.I.R. as shown in Fig.11.
5. For the FG52M, FG52MV and FG57M, install the plunger cover A [N] with the socket head cap screws [03]. Adjust so that the runout of diameter is less than 0.02 mm T.I.R. as shown in Fig.11.
6. Using the connecting handle [G], as shown in Fig.12, adjust the position of plunger [D] and install the key plate [Q] with the socket head cap screws [01]. Then, move the chuck over full stroke to check that the specified stroke is obtained.
7. Install the plunger cover [M] with the socket head cap screws [02].
8. Install the lever, balance pins, floating, and centering jig.



- **Always tighten the bolts at the specified torque. If the torque is insufficient or excessive, the bolt will break, which is dangerous as the chuck or work will fly out.**
- **Use the bolts attached to the chuck, and do not use other bolts. However, if you must use other bolts not provided by Kitagawa, use bolts that have at least a strength classification of 12.9 (10.9 for M22 or more) and be sure they are long enough.**

Table 5

Bolt size	Tightening torque	
M5	7.5	N·m
M6	13	N·m
M8	33	N·m
M10	73	N·m
M12	107	N·m
M14	171	N·m
M16	250	N·m
M20	402	N·m

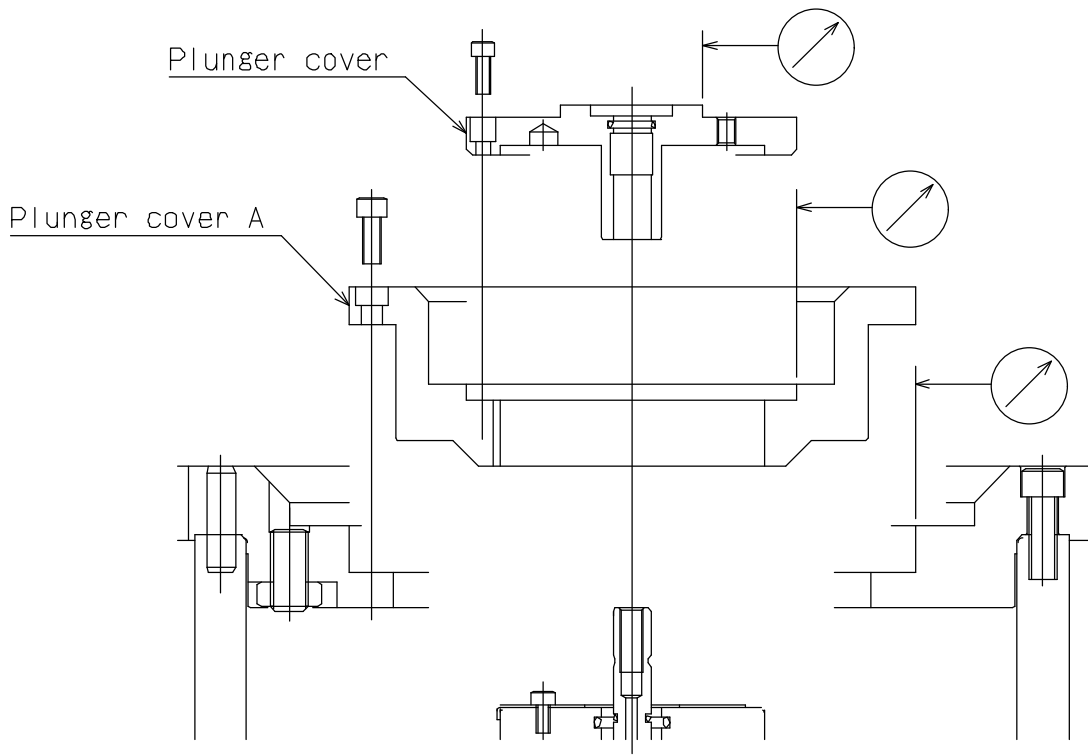

Fig.11

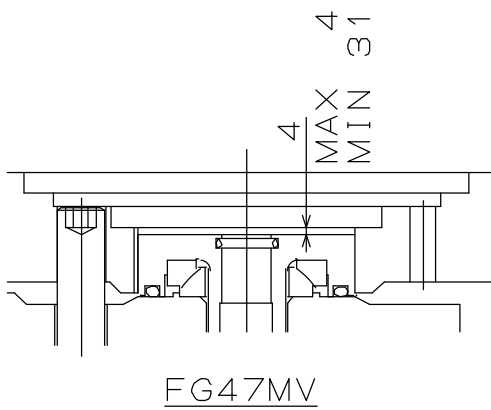
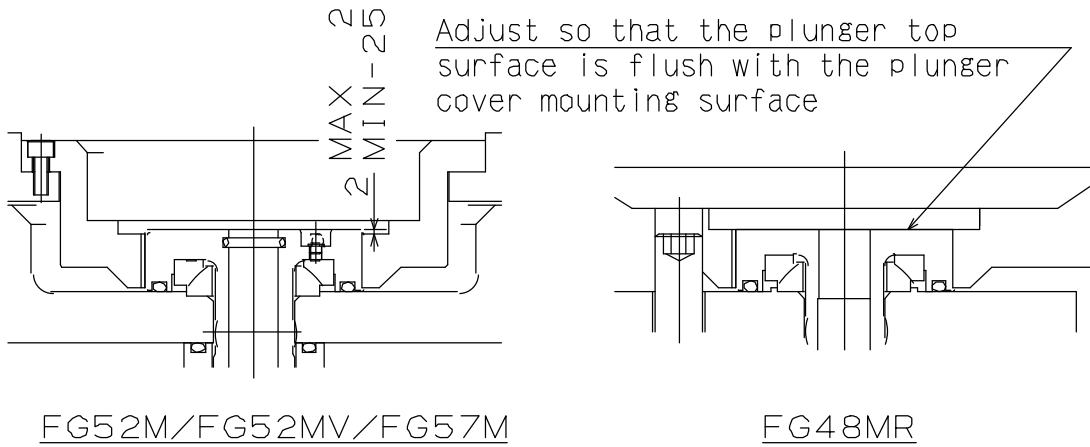

Fig.12

7. Malfunction and Countermeasures

7-1. In the case of malfunction

Check the points specified in the table below and take the appropriate countermeasure.

Table 6

Defective	Cause	Countermeasure
The chuck does not operate.	The chuck inside will break.	Disassemble and replace the broken part.
	The sliding surface is seized.	Disassemble, correct the seized part with oilstone, etc., or replace the part.
	The cylinder is not operating.	Check the piping and the electric system, and if there is no abnormality, disassemble and clean the cylinder.
Insufficient stroke of the lever.	Chips accumulate in guide groove of the lever.	Remove the lever and clean it.
The Work slips.	The stroke of the lever is insufficient.	Remove the lever and clean it.
	The gripping force is insufficient.	Check that the correct hydraulic pressure is obtained.
	The cutting force is too large.	Calculate the cutting force and check that it is suitable for the specification of the chuck.
	The rotation speed is too high.	Slow down to appropriate rotary speed.
Precision failure.	Centering jig or chuck body runs out.	Check respective parts for diameter runout and end face runout.
	Contact surface of centering jig to the workpiece has worn.	Correct the centering jig or replace the parts.
	The gripping force is too large leading to the work being deformed.	Lower the gripping force in the range possible to process to prevent deformation.

 **WARNING**

- If the chuck failed due to a seizure or breakage, remove the chuck from the machine, following the disassembly steps in page 25. When the chuck cannot be removed due to a blockage of workpiece, do not disassemble forcibly but please contact us or our agent.
- If these countermeasures do not correct the problem or improve the situation. Immediately stop using the machine. Continuous use of a broken product or a defective product may cause a serious accident by the chuck or the work flying out.
- Only experienced and trained personnel should do repairs and fix malfunctions. Repair of a malfunction by a person who has never received instruction from an experienced person, the distributor or our company may cause a serious accident.

7-2. Where to contact in the case of malfunction

In the case of malfunction, contact the distributor where you purchased the product or our branch office listed on the back cover.

For Machine Tool Manufactures

Following pages are described for machine tool manufacturers (personnel who attach a chuck to a machine). Please read following instruction carefully when you attach or detach a chuck to machine, and please sufficiently understand and follow the instructions for safe operation.

8. Attachment

8-1. Outline drawing of attachment

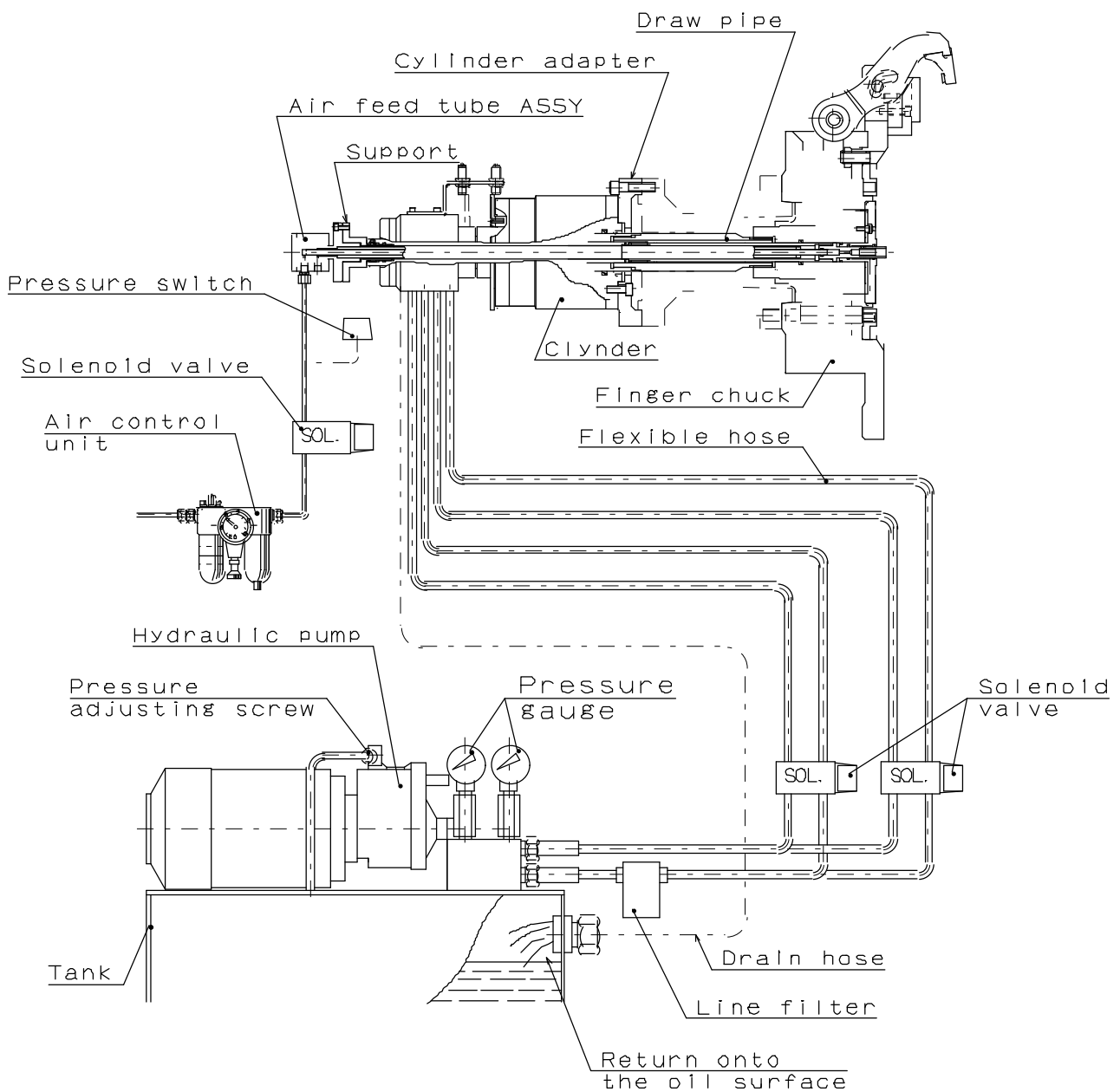

Fig.13

- Attach the manual switching valve at a position where it is easy to operate for the attaching equipment.
- Install the hydraulic unit at a position where the drain hose is not kinked and the needle of the pressure gauge is easily read.

DANGER

- **When other actuators are operated by the same hydraulic pressure source as the cylinder for chuck, be sure that a pressure drop of the cylinder does not occur during use. A hydraulic pressure drop leads to a drop in the gripping force which could allow the work to fly out.**
- **As to the drain hose**
 - **Use a transparent vinyl hose for visualization.**
 - **Provide a stream slope, without air pocket. This will ensure no back pressure.**
 - **The end of the hose is physically above the oil level. (Refer to Fig.13)**
- **If the hydraulic oil stagnates inside the cylinder, oil leakage occurs, which may cause a fire.**

WARNING

- **Install after removing the dust inside the pipe completely.**
- **Add a filter to the pressure supply line. If foreign matters gets inside the cylinder, this is dangerous since the rotation valve of the cylinder will seize, the hose will tear off, and the cylinder will rotate. This is also dangerous as the work will fly out.**
- **Always use a flexible hose for the hydraulic piping to the cylinder, and the bending force or tensile force of the pipe must not be applied to the cylinder. Use a pipe inside diameter as large as possible and keep the piping length as short as possible.**

NOTICE

- Especially, when a large sized hydraulic unit is used, excessive surge pressure is generated and the gripping force becomes large, therefore, it may result in breakage of the chuck or the lowering of endurance. Restrain the surge pressure by adopting a throttle valve, etc.

8-2. Design of chuck open/close hydraulic circuit

- Fig.14 shows an example of chuck open/close hydraulic circuit.
- Use the solenoid valve having 4 ports, 2 positions, and the circuit must hold the gripping port position when current is not applied.
- Use the hydraulic pipes having the inside diameter over 9 mm.

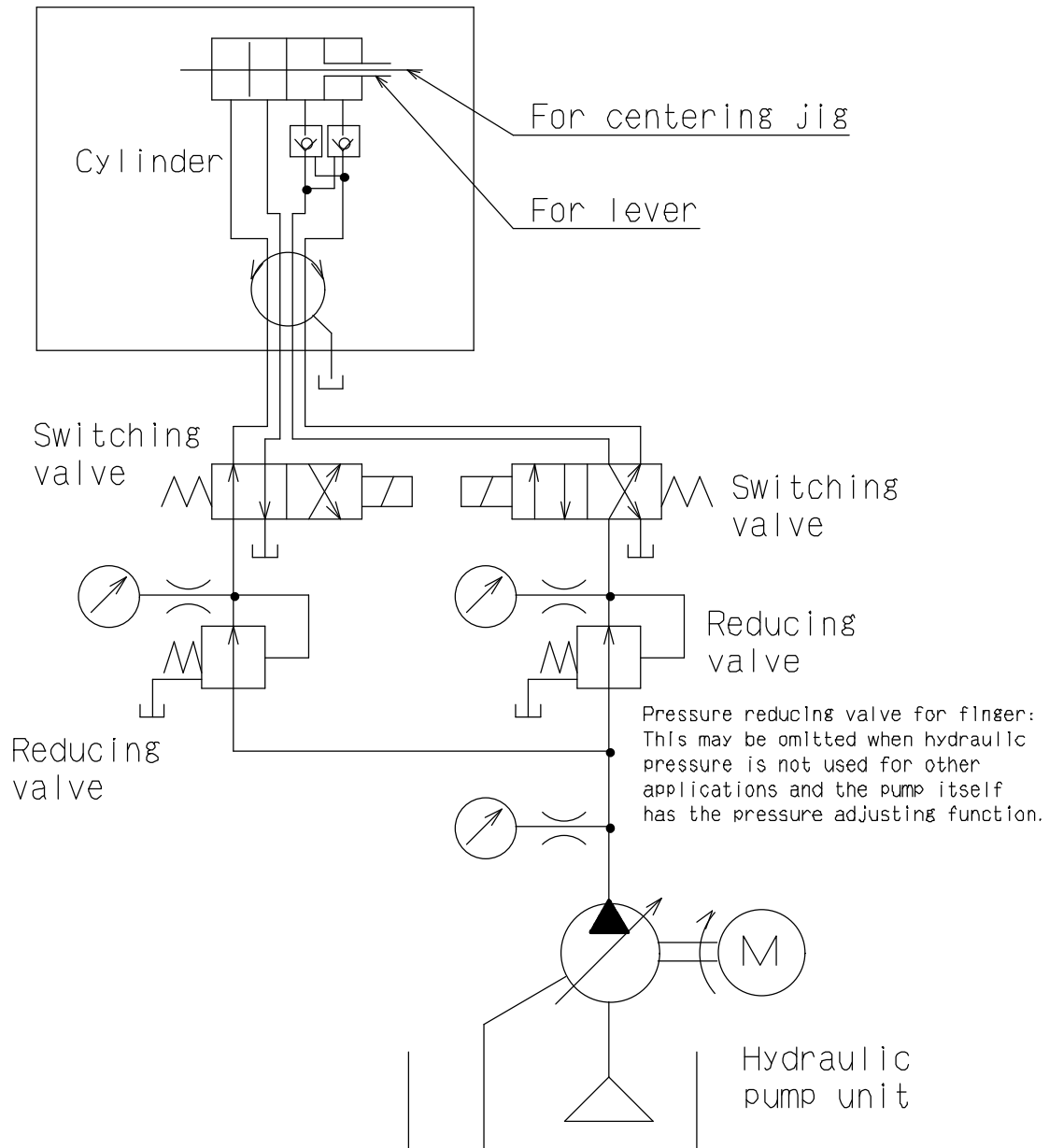

Fig.14

8-3. Design of seating confirmation air circuit

Fig.15 shows an example of seating confirmation air circuit.

- The solenoid valve for seating confirmation must be in detected state when current is applied.
- Use the air pipes having the inside diameter over 4 mm.

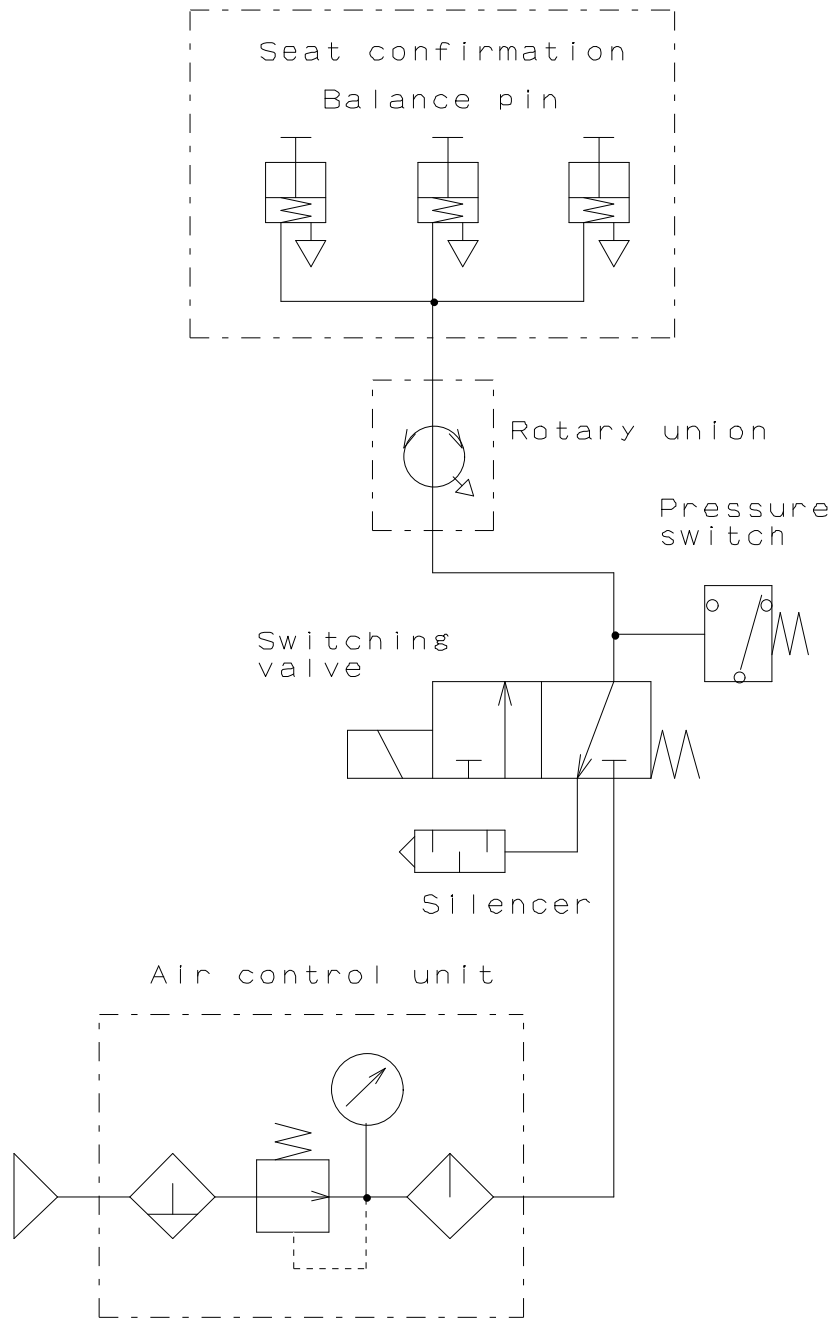

Fig.15

8-4. Design of the draw pipe

- If you design the draw pipe, refer to the Spec. information for supply for the shape and specification.



- **Provide sufficient strength for the draw pipe.** If the draw pipe is broken due to insufficiency of the strength, the gripping force will be lost instantly, which is dangerous as the work will fly out.
 - The personnel who designed draw pipe must judge whether the strength of the draw pipe is sufficient for the usage conditions.
- **If the screw-in depth of the draw pipe to the draw nut is insufficient,** the screw will break and the gripping force will be lost instantly, which is dangerous as the work will fly out.
- **If the engagement of the screw of the draw pipe is loose,** vibration may occur resulting in breakage of the screw. If the screw breaks, the gripping force will be lost instantly, which is dangerous as the work will fly out.
- **If the draw pipe is unbalanced, vibration occurs,** the screw is broken and the gripping force will be lost instantly, which is dangerous as the work will fly out.

8-5. Attachment of chuck

1. Attaching the draw pipe to the cylinder

- Apply adhesive onto the screw part of the draw pipe, and screw it into the piston rod of cylinder. At this time, refer to the instruction manual for the cylinder for tightening torque.

NOTICE

- When the draw-pipe is attached to the cylinder, if it is tightened in middle position of piston stroke, the piston locking pin may be broken. For the YG-204 type cylinder, with small and large piston rods pushed in fully, screw in the draw-pipe on small piston side, and then with large piston rod pulled out fully, screw in the draw-pipe on large piston side. For other cylinders, refer to the Cylinder Instruction Manual.

2. Attaching the air feed tube to the cylinder

- Install the air feed tube (rotary joint) from the cylinder rear side, and then install the relay draw-pipe at the leading end of the draw-pipe on the small piston side.

3. Attach the cylinder to the spindle (or the cylinder adapter)

- Check the run-out of the cylinder, and if it is normal, attach the hydraulic pipe.
- Move 2 to 3 times at low pressure (0.4 MPa-0.5 MPa, 4 - 5 kgf/cm²) and set the piston at the forward end and turn off the power supply.

CAUTION

- Use an eyebolt when attaching and detaching the chuck to and from the machine, as there is a danger of injury or damage if the chuck drops.

WARNING

- Remove the eyebolt without fail after using. If the chuck is rotated with the eyebolt, etc., attached, they may fly out and this is dangerous.

4. Connect the chuck to the draw pipe

- Remove the centering jig, plunger cover (also plunger cover A for FG52M, FG52MV and FG57M) and key plate of the chuck, and rotate the plunger by the connecting handle to joint the chuck to the draw-pipe.
- When connecting the plunger and the draw pipe, do not forcibly screw them in if they cannot be screwed smoothly, but check the inclination of the core of the screw, etc.

DANGER

- If the screw-in depth of the draw pipe to the plunger is insufficient, the screw will break and the gripping force will be lost instantly, which will the work to fly out.
- If the engagement of the screw of the draw pipe is loose, vibration may occur resulting in breakage of the screw, loss of gripping force and the work flying out.

5. Attach the chuck matching to the attaching surface of the spindle (or the back plate).

- Turn the connecting handle to make a state that the chuck closely contacts the spindle attaching surface of the lathe.
- In the case of adjusting the centering of the chuck, lightly hit the body side face with a plastic hammer.
- Tighten the chuck attaching bolts evenly. At this time, tighten the bolts at the specified torque.



- **Always tighten the bolts at the specified torque. If the torque is insufficient or excessive, the bolt will break, which is dangerous as the chuck or work will fly out.**
- **Use the bolts attached to the chuck, and do not use other bolts. However, if you must use other bolts not provided by Kitagawa, use bolts that have at least a strength classification of 12.9 (10.9 for M22 or more) and be sure they are long enough.**

Table 7

Bolt size	Tightening torque	
M5	7.5	N·m
M6	13	N·m
M8	33	N·m
M10	73	N·m
M12	107	N·m
M14	171	N·m
M16	250	N·m
M20	402	N·m

6. Adjust the position of the wedge plunger

- Using the connecting handle, adjust the plunger position as shown in Fig.17, and then install the key plate to lock.
- Move the chuck over full stroke to check that the specified stroke is obtained.
- Install plunger cover (also plunger cover A for FG52M, FG52MV and FG57M), and adjust each part so that the runout of diameter is less than 0.02 mm T.I.R. as shown in Fig.16.

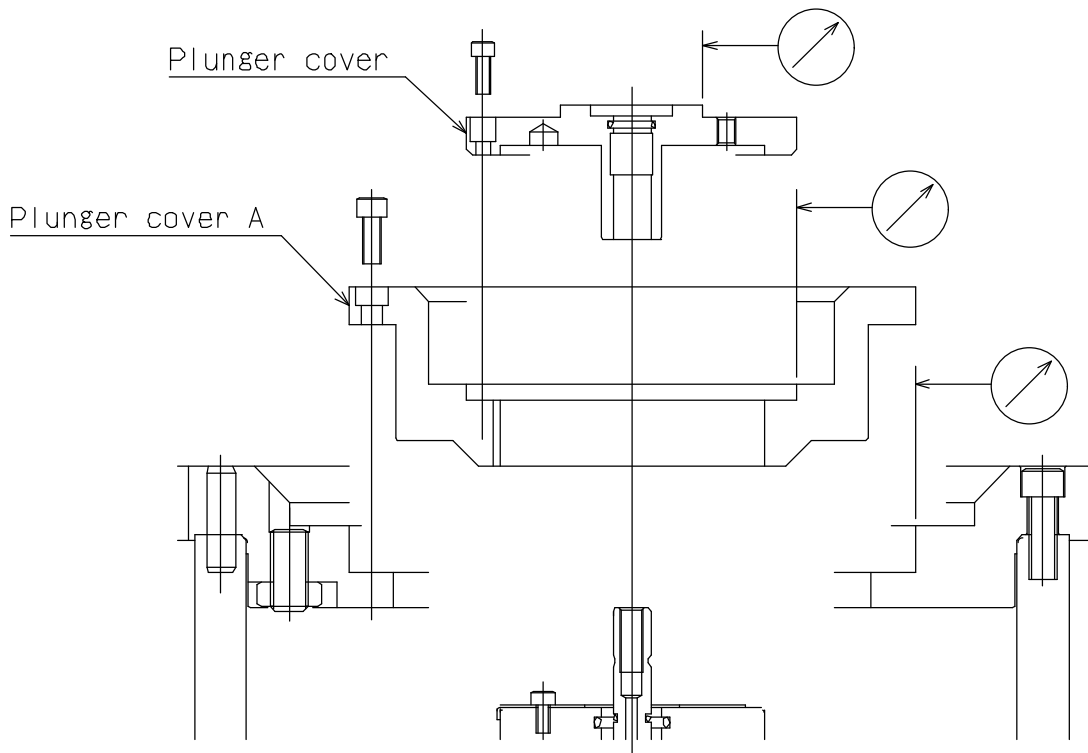

Fig.16

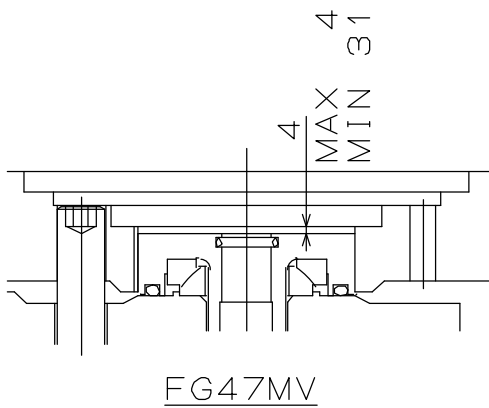
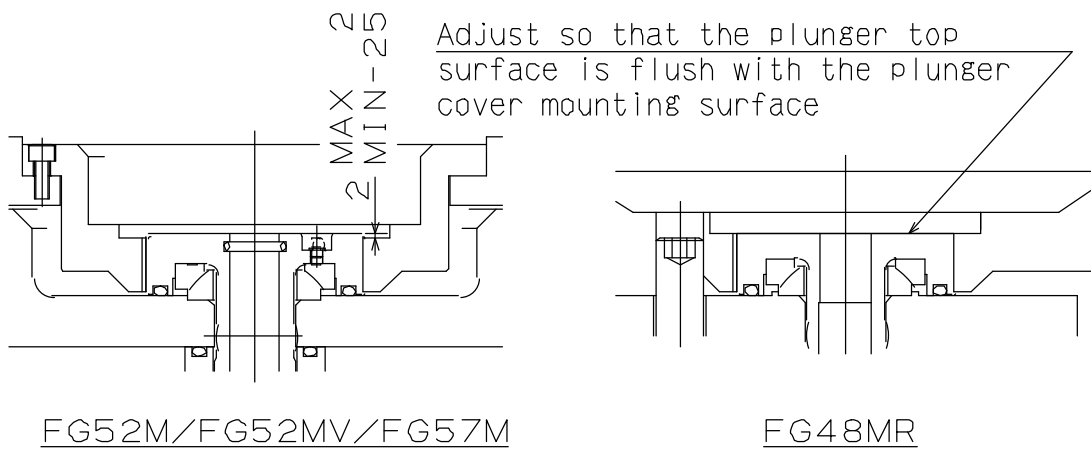

Fig.17

9. Other information

9-1.About disposal

Ultimate disposal of this product should be handled according to all national laws and regulations.



<http://www.mta.kiw.co.jp>

KITAGAWA IRON WORKS CO., LTD.

77-1 Motomachi Fuchu-shi, Hiroshima-pref., 726-8610, Japan

TEL +81-847-40-0526 FAX +81-847-45-8911

America Contact	KITAGAWA-NORTHTECH INC. http://www.kitagawa.com 301 E. Commerce Dr, Schaumburg, IL. 60173 USA TEL +1 847-310-8787 FAX +1 847-310-9484
Europe Contact	KITAGAWA EUROPE LTD. http://www.kitagawaeurope.com Unit 1 The Headlands, Downton, Salisbury, Wiltshire SP5 3JJ, United Kingdom TEL +44 1725-514000 FAX +44 1725-514001
	KITAGAWA EUROPE GmbH http://www.kitagawaeurope.de Reeserstrasse 13, 40474, Dusseldorf Germany TEL +49 211-550294-0 FAX +49 211-55029479
	KITAGAWA EUROPE GmbH Poland Office TEL +48 607-39-8855 FAX +48 32 -749- 5918
Asia Contact	KITAGAWA INDIA PVT LTD. Lotus House East, Lane 'E' North Main Road, Koregaon Park, Pune, 411001, Maharashtra, India Tel: +91 20 6500 5981 FAX +91 20 2615 0588
	KITAGAWA (THAILAND) CO., LTD. Bangkok Office 9th FL, Home Place Office Building, 283/43 Sukhumvit 55Rd. (Thonglor 13),Klongton-Nua, Wattana, Bangkok 10110, Thailand TEL +66 2-712-7479 FAX +66 2-712-7481
	KITAGAWA IRON WORKS CO., LTD. Singapore Branch #02-01 One Fullerton, 1 Fullerton Road, Singapore 049213 TEL +65 6838-4318 FAX +65-6408-3935
	KITAGAWA IRON WORKS (SHANGHAI) CO., LTD. Room308 3F Building B. Far East International Plaza, No.317 Xian Xia Road, Chang Ning, Shanghai, 200051 China TEL +86 21-6295-5772 FAX +86 21-6295-5792
	DEAMARK LIMITED http://www.deamark.com.tw No. 6, Lane 5, Lin Sen North Road, Taipei, Taiwan TEL +886 2-2393-1221 FAX +886 2-2395-1231
	KITAGAWA KOREA AGENT CO., LTD. http://www.kitagawa.co.kr 803 Ho, B-Dong, Woolim Lion's Valley, 371-28 Gasan-Dong, Gumcheon-Gu, Seoul, Korea TEL +82 2-2026-2222 FAX +82 2-2026-2113
Oceania Contact	DIMAC TOOLING PTY LTD. http://www.dimac.com.au 61-65 Geddes Street, Mulgrave, Victoria, 3170 Australia TEL +61 3-9561-6155 FAX +61 3-9561-6705

The products herein are controlled under Japanese Foreign Exchange and Foreign Trade Control Act. In the event of importing and/or exporting the products, you are obliged to consult KITAGAWA as well as your government for the related regulation prior to any transaction.

2012.02.