



CHUCK

立形旋盤用大型チャック Large Power Chuck for Vertical Lathes NV series

立形旋盤でも安心なシールタイプ Low maintenance Power Chuck for Vertical Lathes Sealed 切粉、切削水をダブルシャットアウト Base Jaw to prevent Chips and Coolant ingress



●切粉、切削水侵入防止
Protection against Swarf and Coolant
プロテクタとスクレーパが、チャック内への切粉、切削水侵入を防ぎます。もし侵入しても、バックプレートの水抜き溝が主軸内への切削水封入を防ぎます。
Protector and Scraper at Base Jaw prevent Swarf and Coolant ingress.

●標準ジョー使用 Standard Jaw
スクレーパがボデー装着のため、標準ジョーの使用が可能になりました。特殊ジョーの使用が不要で、設備コストを低減します。
NV series is compatible with standard Hard and Soft Jaws as sealing is at the Base Jaw.

*CE対応品 *CE correspondence

■寸法図 Dimensional Drawings

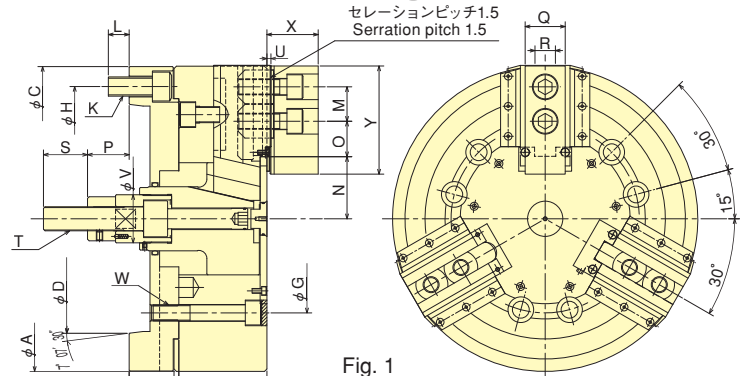

Fig. 1

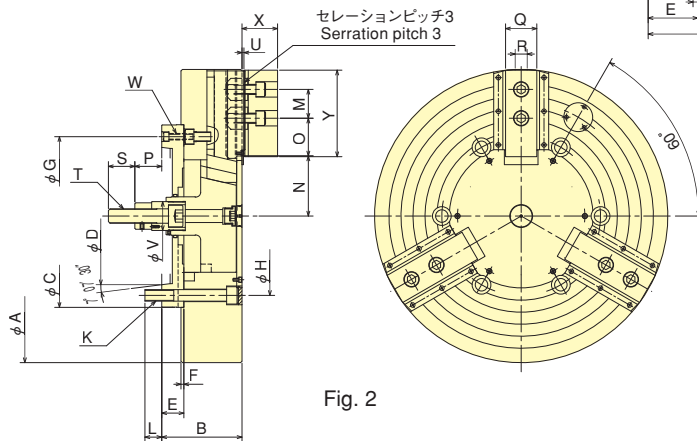
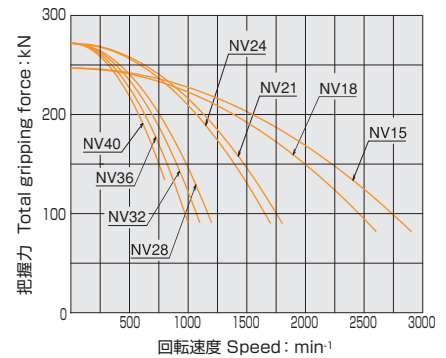

Fig. 2

把握力性能曲線 Gripping Characteristic Graphs

※線は標準ソフトジョーを用いた場合のもので、
※With standard blank soft top jaw.



■寸法表 Dimensions ※NV15、NV18はFig.1による。NV21、NV24、NV28、NV32、NV36、NV40はFig.2による。※NV15&18 are based on Fig.1. NV21~40 are based on Fig.2.

型式 Model	A	B	C	D	E	F	G	H	K	L	M	N max.	N min.	O max.	O min.	P max.	P min.	Q	R	S	T	U	V	W	X	Y
NV15C15	381	172	380	285.775	62	6	235.0	330.2	6-M24	26	43	77.5	69.5	48.75	23.25	91	56	50	25.5	55	M30	5	60	6-M20	64	135
NV18C15	450	172	380	285.775	62	6	235.0	330.2	6-M24	26	43	108	100	48.75	23.25	91	56	50	25.5	55	M30	5	60	6-M20	64	135
NV21C15	530	167	380	285.775	46	6	330.2	330.2	6-M24	35	60	86	78	93.5	27.5	91	56	65	25.0	55	M30	6	60	3-M12	74	180
NV24C15	610	167	380	285.775	46	6	330.2	330.2	6-M24	29	60	125	117	93.5	27.5	91	56	65	25.0	55	M30	6	60	3-M12	74	180
NV28C15	700	167	380	285.775	46	6	330.2	330.2	6-M24	29	60	125	117	141.5	27.5	91	56	65	25.0	55	M30	6	60	3-M12	74	180
NV32C15	800	167	380	285.775	46	6	330.2	330.2	6-M24	29	60	125	117	189.5	27.5	91	56	65	25.0	55	M30	6	60	3-M12	74	180
NV36C15	914	167	380	285.775	46	6	330.2	330.2	6-M24	29	60	125	117	249.5	27.5	91	56	65	25.0	55	M30	6	60	3-M12	74	180
NV40C15	1000	167	380	285.775	46	6	330.2	330.2	6-M24	29	60	125	117	282.5	27.5	91	56	65	25.0	55	M30	6	60	3-M12	74	180

■仕様表 Specifications ※把握径/把握範囲は標準のソフトジョーを使用した場合。※Gripping dia./gripping range is with standard soft jaws.

型式 Model	把握径 Gripping range mm		ジョーストローク (直径) Jaw Stroke (diameter) mm	プランジャストローク Plunger Stroke mm	許容最大入力 Max. Draw Bar Pull Force kN(kgf)	最大静的把握力 Max. Gripping Force kN(kgf)	許容最高回転速度 Max. Speed min ⁻¹	質量 (標準ソフトジョー) Net Weight with Soft top jaws kg	慣性モーメント Moment of inertia kg·m ²	適合シリンダ Matching Cylinder	許容最大油圧力 Max. pressure MPa(kgf/cm ²)	標準ソフトジョー Matching Soft top jaw	主軸端呼び Spindle nose size
	Max.	Min.											
NV15C15	381	72	16	35	82 (8362)	247 (25187)	2900	139	2.7	Y2035R/RE	3.2 (32.6)	SJ15N1	A2-15
NV18C15	450	133	16	35	82 (8362)	247 (25187)	2600	166	4.1	Y2035R/RE	3.2 (32.6)	SJ15N1	A2-15
NV21C15	530	69	16	35	82 (8362)	272 (27736)	1800	227	7.6	Y2035R/RE	3.2 (32.6)	SJ18A2	A2-15
NV24C15	610	152	16	35	82 (8362)	272 (27736)	1700	282	12.8	Y2035R/RE	3.2 (32.6)	SJ18A2	A2-15
NV28C15	700	152	16	35	82 (8362)	272 (27736)	1200	360	21.9	Y2035R/RE	3.2 (32.6)	SJ18A2	A2-15
NV32C15	800	152	16	35	82 (8362)	272 (27736)	1100	472	37.2	Y2035R/RE	3.2 (32.6)	SJ18A2	A2-15
NV36C15	914	152	16	35	82 (8362)	272 (27736)	1000	594	62.4	Y2035R/RE	3.2 (32.6)	SJ18A2	A2-15
NV40C15	1000	152	16	35	82 (8362)	272 (27736)	800	738	91.5	Y2035R/RE	3.2 (32.6)	SJ18A2	A2-15

※上記は主軸端がA2-15の場合の仕様です。A2-11への対応も可能です。
※The above dimensions are based on A2-15 Spindle Nose. A2-11 Spindle Nose is available.