



**CHUCK**

# 大口徑フロント中空エアチャック Air-Operated Self Contained Chuck UPR series

## 油井管規格に適合したエアチャック

Air-operated chuck perfect for oil pipe standards

- チャックの着脱が容易な構造 Easy installation
  - 芯出し調整が容易 Easy centering adjustment
  - メンテナンス性の向上。 Service & maintenance improved.  
消耗品の部品交換が容易 Easy replacing consumable parts
- \*CE対応品 \*CE correspondence



スタンダードチャック  
Standard Chuck

### ■ 寸法図 Dimensional Drawings

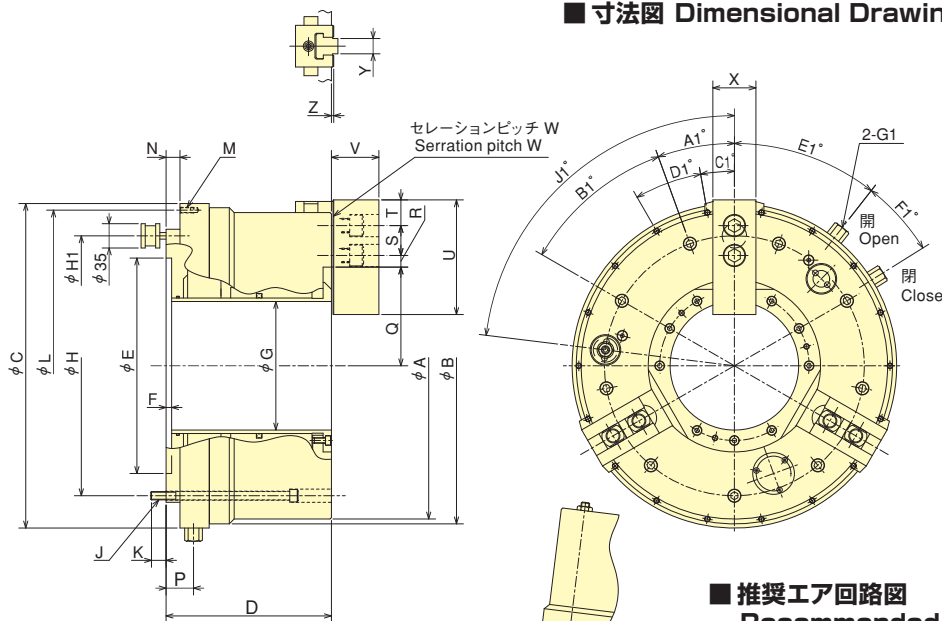

\*チャック表面を上向きで使用する場合はご相談下さい。  
\*Consult us in case of Chuck face is used for upper position.

### ■ 推奨エア回路図

Recommended air circuit diagram

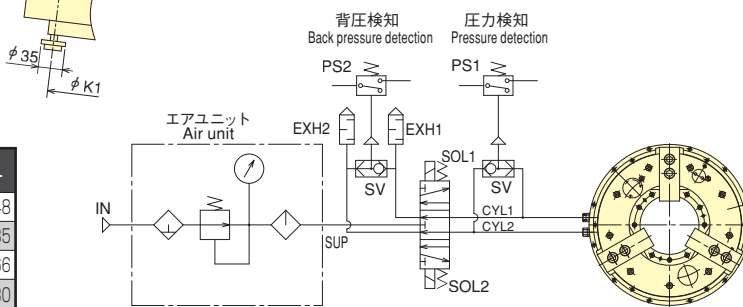

### ■ 寸法表 Dimensions

型式 Model	A	B	C (0/0.2)	D	E (H7)	F	G	H	J	K	L
UPR450	441	455	467	238	310	8	185	374	9-M12	22	448
UPR600	590	605	605	272	450	8	275	508	12-M12	22	585
UPR650	655	675	685	283	510	8	325	580	12-M16	24	666
UPR710	715	740	750	283	550	8	375	620	9-M16	24	730
UPR910	915	915	925	291	700	10	560	800	12-M16	26	905

型式 Model	M	N	P	Q max.	Q min.	R max.	R min.	S	T	U	V	W	X	Y (h8)	Z	A1	B1	C1	D1	E1	F1	G1	H1	J1	K1
UPR450	18-M8 ねじ深さ Depth 20	20	39.5	142	122	34.75	16.75	43	37	165	68.3	1.5	62	22	3.3	20°	9×40°	10°	18×20°	38°	20°	Rc3/8	374	83°	374
UPR600	18-M8 ねじ深さ Depth 20	20	50	196.5	171.5	32.5	20.5	60	39.5	180	70.5	3	65	25.5	3.3	15°	12×30°	0°	18×20°	25°	20°	Rc3/8	508	60°	508
UPR650	18-M8 ねじ深さ Depth 20	20	50	223	198	38.5	20.5	60	40	209.5	81.3	3	75	30	3.3	15°	12×30°	0°	18×20°	25°	20°	Rc1/2	580	60°	580
UPR710	18-M8 ねじ深さ Depth 20	20	43	248	223	50.5	23.5	60	40	209.5	81.3	3	75	30	3.3	20°	9×40°	0°	18×20°	30°	15°	Rc1/2	620	45°	620
UPR910	18-M8 ねじ深さ Depth 20	33	56	342	317	50.5	23.5	60	40	209.5	81.3	3	75	30	3.3	15°	12×30°	0°	18×20°	30°	15°	Rc1/2	800	60°	800

### ■ 仕様表 Specifications

\*把握径/把握範囲は標準のソフトジョーを使用した場合。\*Gripping dia./gripping range is with standard soft jaws.

型式 Model	貫通穴径 Thru-Hole mm	把握径 Gripping range mm		ジョーストローク (直径) Jaw Stroke (diameter) mm		プランジャストローク Plunger Stroke mm	最大静的把握力 Max. Gripping force kN(kgf)	許容最高回転速度 Max. Speed min <sup>-1</sup>	質量 Net Weight kg	慣性モーメント Moment of inertia kg·m <sup>2</sup>	許容最大エア圧力 Max. pressure MPa(kgf/cm <sup>2</sup> )
		Max.	Min.	早送り Rapid	把握送り Gripping						
UPR450	185	441	131	26	14	53	100 (10197)	1300	195	5.5	0.6
UPR600	275	590	241	33	17	53.5	120 (12236)	1100	365	19.7	0.5
UPR650	325	655	239	33	17	53.5	147 (14990)	1000	476	32.2	0.6
UPR710	375	715	301	33	17	53.5	162 (16519)	900	532	43.1	0.6
UPR910	560	915	477	33	17	53.5	162 (16519)	600	735	103	0.5