

**WORK GRIPPER**

2爪ワークグリッパ

AT series

突起物ワークも確実把握

M/C関係のワークホールディングもKITAGAWA

- エアシリンダを内蔵した薄型・軽量設計
- エア配管だけで取付け簡単
- バーワークやエアブローに最適の中空構造
- 当社パワーチャックとのソフトジョー共用可能
- オプションのロックバルブユニット使用により、配管を外して加工可能

*ロックバルブユニット使用時はCE対応品

※配管回路にルブリケータを設けてください。

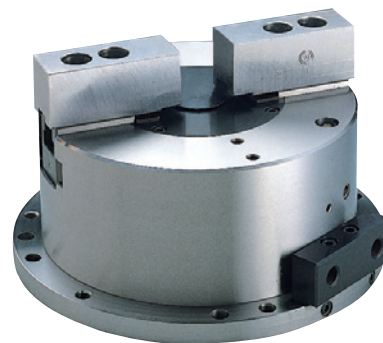

■ 寸法図

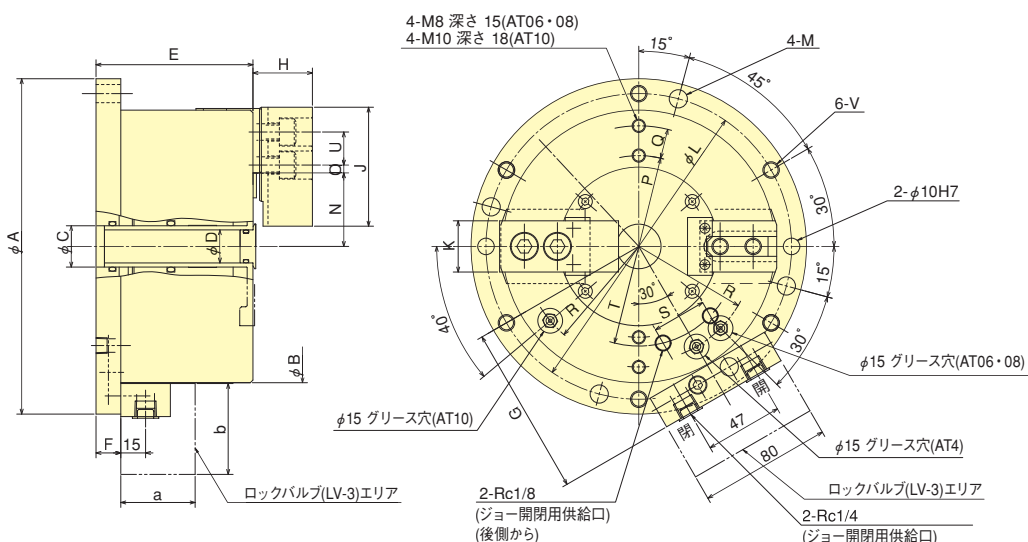

■ 寸法表 ※a, bの寸法はLV-3(ロックバルブ)の寸法

型式	寸法	φA (H7)	φB	φC	φD	E	F	G	G	H	J	K	φL (±0.2)	φM	N max.	N min.	O max.	O min.	P	Q
AT04		148	110	20H7	-	90	15	75.5	(110.5)	27	55	23	130	9	25.5	22.9	8.75	7.25	-	-
AT06		203	165	25H7	20	95	15	103	(138)	36	72	31	185	11	44.5	41.9	9.25	4.75	55	18
AT08		248	210	36H7	30	106	15	125.5	(160.5)	42	95	35	230	11	53	49.85	15	9	68	25
AT10		300	254	50H7	43	110	16	147.5	(182.5)	46	110	40	280	13	66	62.85	16	8.5	85	30

型式	寸法	R	S	T	U	V	a	b
AT04		43	33	34	14	M8	45	55
AT06		70	33	60.3	20	M10	45	55
AT08		90	33	80	25	M10	45	55
AT10		110	33	95	30	M12	45	55

■ 仕様表 ※空気消費量はプランジャストローク10mm当り、圧力0.6MPa時 ※把握径/把握範囲は標準のソフトジョーを使用した場合。

型式	仕様	ジョーストローク (直径) mm	把握力 [エア圧力 0.6MPa] kN	質量 kg	許容最大エア圧力 MPa	適用ソフトジョー	把握径 mm		空気消費量 (N _l)
							Max.	Min.	
AT04		5.2	7.5	6.9	0.6	SJ04A1T	110	10	0.40
AT06		5.2	21.0	15.0	0.6	SJ06A1T	165	31	1.04
AT08		6.3	33.0	26.7	0.6	SJ08A1	210	41	1.81
AT10		6.3	48.0	40.8	0.6	SJ10A1	254	61	2.52



WORK GRIPPER

2-Jaw Work Gripper

AT series

Secure gripping of all types of component
Can be used as an alternative to a fixture

- Small and lightweight design, with inbuilt air cylinder
- Easy mounting by air piping
- Hollow structure optimal for bar work-piece and air blow
- Standard Soft Jaw for Power Chuck is used
- By using the optional lock valve unit, it is possible to remove the piping during machining

*CE compliant when lock valve is used

※Provide a lubricater in the piping circuit.

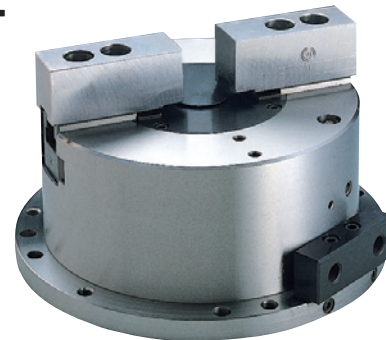

Dimensional Drawings

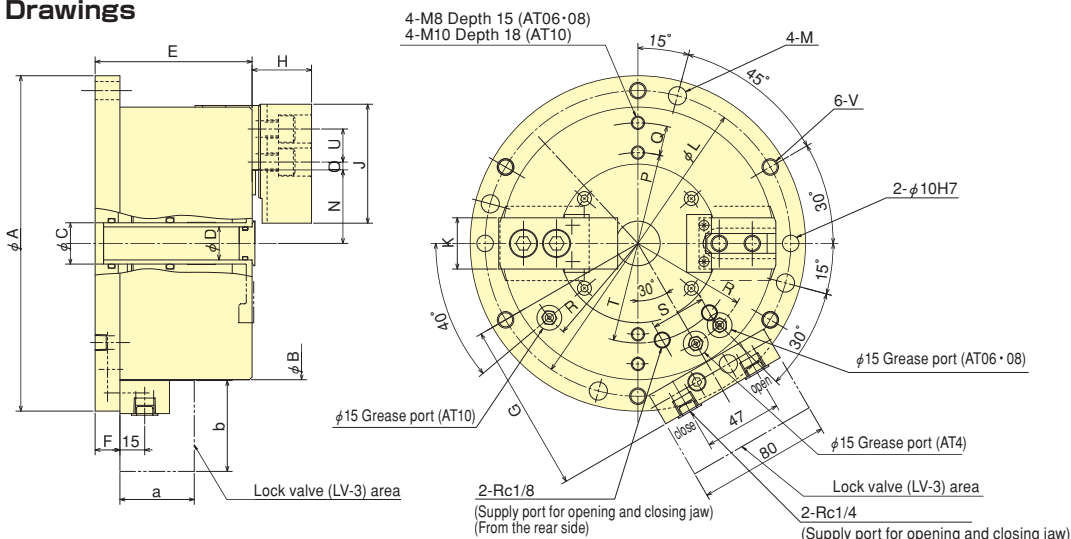

Dimensions

※The dimensions of a/b marked are the size of LV-3(Lock-valve).

Model	Dimensions	φA (H7)	φB	φC	φD	E	F	G	G	H	J	K	φL (±0.2)	φM	N max.	N min.	O max.	O min.	P	Q
AT04		148	110	20H7	—	90	15	75.5 (1105)		27	55	23	130	9	25.5	22.9	8.75	7.25	—	—
AT06		203	165	25H7	20	95	15	103 (138)		36	72	31	185	11	44.5	41.9	9.25	4.75	55	18
AT08		248	210	36H7	30	106	15	125.5 (1605)		42	95	35	230	11	53	49.85	15	9	68	25
AT10		300	254	50H7	43	110	16	147.5 (1825)		46	110	40	280	13	66	62.85	16	8.5	85	30

Model	Dimensions	R	S	T	U	V	a	b
AT04		43	33	34	14	M8	45	55
AT06		70	33	60.3	20	M10	45	55
AT08		90	33	80	25	M10	45	55
AT10		110	33	95	30	M12	45	55

Specifications

※Air Consumption = Under Pressure 0.6MPa Plunger Stroke per 10mm
 ※Gripping dia./gripping range is with standard soft jaws.

Model	Specifications	Jaw Stroke (diameter) mm	Gripping Force [Pneumatic at 0.6MPa] kN	Net Weight kg	Max. air pressure MPa	Matching Soft top jaw	Gripping range mm		Air consumption (N _l)
							Max.	Min.	
AT04		5.2	7.5	6.9	0.6	SJ04A1T	110	10	0.40
AT06		5.2	21.0	15.0	0.6	SJ06A1T	165	31	1.04
AT08		6.3	33.0	26.7	0.6	SJ08A1	210	41	1.81
AT10		6.3	48.0	40.8	0.6	SJ10A1	254	61	2.52

ワークグripper Work Gripper