



CHUCK

大口径フロント中空エアチャック

UB series

エアシリンダ内蔵 パイプ加工に最適な大型チャック



- ジョー位置検出が対応可能
- 内圧検知可能
- *CE対応品

■ 寸法図

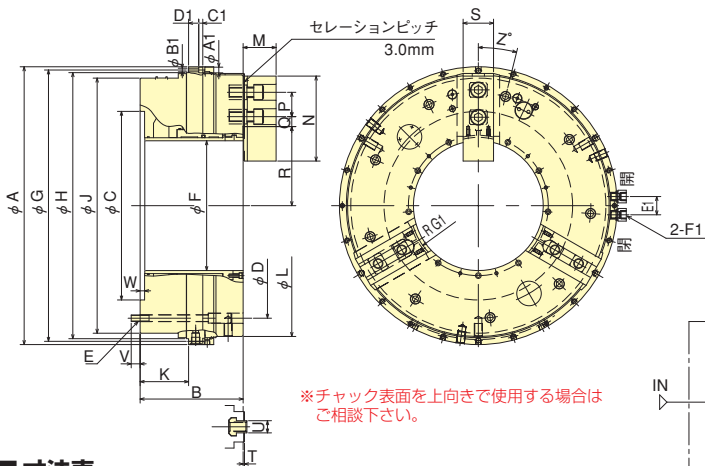

■ 推奨エア回路図

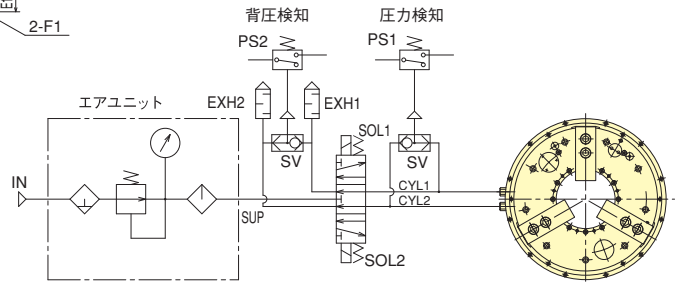

■ 寸法表

型式	A1	B1	C1	D1	E1	F1	G1
UB450K	11	6.6	6.6	25	45	Rc3/8	87.5
UB560K	14	9	9	20	45	Rc1/2	134
UB630K	14	9	10	25	45	Rc1/2	160
UB710K	17	11	11	33	45	Rc1/2	185

型式	A	B	C (H7)	D	E	F	G	H (H7)	J	K	L	M ミレシ	N	P	Q max.	Q min.	R max.	R min.	S	T	U	V	W	Z	
UB450K	494	212	275	373	9-M12	181	481	470	431	98.5	441	67.3	68.7	165	43	41.5	17.5	121.4	114.4	62	3.3	25.5	17	6	20
UB560K	626	230	375	485	6-M16	275	610	595	556	113.5	568	70.5	71.9	180	60	42	18	169	160.5	65	3.3	25.5	24	11	40
UB630K	698	254	465	555	9-M16	320	682	669	629	119.5	645	81.3	82.7	209.5	60	50.5	23.5	195	186.5	75	3.3	30	22	11	14
UB710K	790	252	520	620	9-M16	375	770	745	702	118.5	714	81.3	82.7	209.5	60	62.3	26.3	222.5	211.5	75	3.3	30	24	11	24

■ 仕様表

*把握径/把握範囲は標準のソフトジョーを使用した場合。

型式	貫通穴径 mm	把握径 mm		ジョーストローク (直径) mm	プランジャ ストローク mm	最大静的把握力 kN	許容最高回転速度 min ⁻¹	質量 (標準ソフトジョー付) kg	慣性モーメント kg·m ²	許容最大エア圧力 MPa	空気消費量 10mm当り (7圧0.6MPa) ℓ
		Max.	Min.								
UB450K	181	441	117	14	40	100	1300	204	5.55	0.6	4.83
UB560K	275	568	215	17	37	120	1100	320	15.8	0.6	7.17
UB630K	320	645	223	17	37	162	1000	480	28.1	0.6	9.27
UB710K	375	714	278	22	36	144	900	550	38.9	0.6	11.10

*最高回転数は空気圧0.6MPa、標準ソフトジョー使用時の数値です。エアサプライリングは必ず固定して、チャックを回転させて下さい。
 *爪1個の締付力は、把握力の1/3となります。 *標準付属品：ソフトジョー、エアプレッシャゲージ。
 *コレットパッド（オプション）使用で上記最小把握径よりも更に小径の把握が可能です。

■ AVF-3-FL型エア手動切換弁（特別付属品）

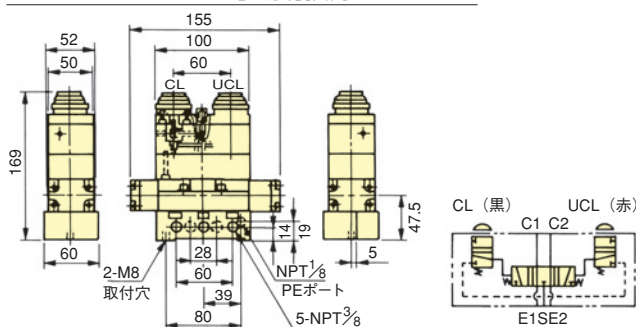

軽量小型でプッシュボタン操作となっており、旋盤に取付けた時、シンプルな配管設計ができるよう考慮しております。本バルブは、エキゾーストセンタタイプでフロント中空エアチャック用に設計されています。

使用圧力	0~1MPa
耐圧力	1.5MPa
押ボタン操作力	4kg
接続口径	Rc3/8



CHUCK

Air-Operated Self Contained Chuck

UB series

Built-in Pneumatic Cylinder

Large chuck best suited for pipe processing



スタンダードチャック
Standard Chuck

- The jaw position can be detected
- Internal pressure can be detected
- *CE correspondence

Dimensional Drawings

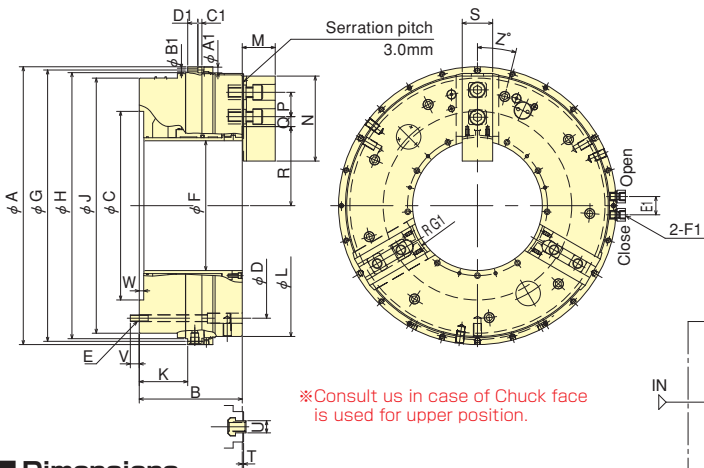

Recommended air circuit diagram

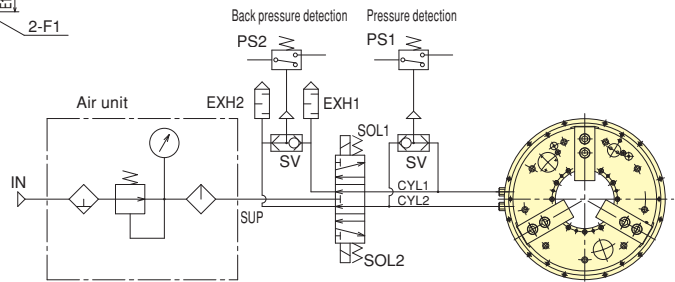

Dimensions

Model	A1	B1	C1	D1	E1	F1	G1
UB450K	11	6.6	6.6	25	45	Rc3/8	87.5
UB560K	14	9	9	20	45	Rc1/2	134
UB630K	14	9	10	25	45	Rc1/2	160
UB710K	17	11	11	33	45	Rc1/2	185

Model	A	B	C (H7)	D	E	F	G	H (H7)	J	K	L	M		N	P	Q max.	Q min.	R max.	R min.	S	T	U	V	W	Z
												mm	inch												
UB450K	494	212	275	373	9-M12	181	481	470	431	98.5	441	67.3	68.7	165	43	41.5	17.5	121.4	114.4	62	3.3	25.5	17	6	20
UB560K	626	230	375	485	6-M16	275	610	595	556	113.5	568	70.5	71.9	180	60	42	18	169	160.5	65	3.3	25.5	24	11	40
UB630K	698	254	465	555	9-M16	320	682	669	629	119.5	645	81.3	82.7	209.5	60	50.5	23.5	195	186.5	75	3.3	30	22	11	14
UB710K	790	252	520	620	9-M16	375	770	745	702	118.5	714	81.3	82.7	209.5	60	62.3	26.3	222.5	211.5	75	3.3	30	24	11	24

Specifications

*Gripping dia./gripping range is with standard soft jaws.

Model	Thru-Hole mm	Gripping range mm		Jaw Stroke (diameter) mm	Plunger Stroke mm	Max. Gripping Force kN	Max. Speed min ⁻¹	Net Weight with Soft top jaws kg	Moment of inertia kg·m ²	Max. pressure MPa	Air consumption per 10mm (at air pressure 0.6MPa) l
		Max.	Min.								
UB450K	181	441	117	14	40	100	1300	204	5.55	0.6	4.83
UB560K	275	568	215	17	37	120	1100	320	15.8	0.6	7.17
UB630K	320	645	223	17	37	162	1000	480	28.1	0.6	9.27
UB710K	375	714	278	22	36	144	900	550	38.9	0.6	11.10

*Maximum speed is shown with each value under air pressure of 0.6MPa, using standard soft jaw and fixed air supply ring.

*Gripping force of a jaw is one third of max. gripping force. *Standard accessories : Soft jaw, air pressure gauge, tools of a set.

*The work-pieces of diameter smaller than the above minimum gripping diameter can be gripped by using a collet pad (option).

AVF-3-FL type manual change valve (Special accessories)

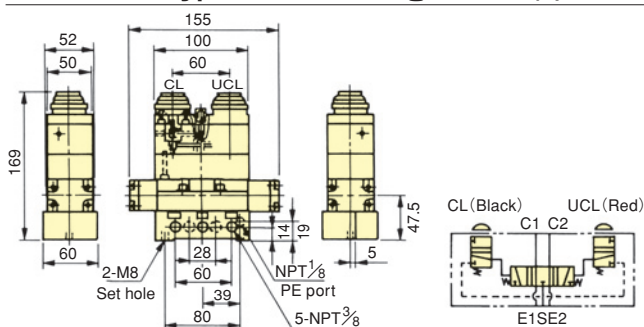

This valve is light-weight, compact and can be operated with the press of a button. The simple piping can be routed when the selector is mounted on the lathe. The valve is the exhaust centre type and designed for exclusive UB types.

Pressure	0~1MPa
Proof pressure	1.5MPa
Push button operation force	4kg
Connection bore	Rc3/8