

INSTRUCTION MANUAL

Y type

ROTARY HYDRAULIC CYLINDER CLOSED CENTER



DANGER

- This instruction manual is for production engineers and maintenance personnel in charge of operation of this product. When a beginner uses this product, receive instructions from experienced personnel, the distributor or our company.
- Before installing, operating or maintaining this equipment, carefully read this manual and the safety labels attached to the equipment. Failure to follow these instructions and safety precautions could result in serious injury, death, or property damage.
- Store this manual near equipment for future reference.
- If any questions related to safety arise about this manual, please confirm them with the distributor or our company.

Kitagawa Corporation

77-1, Motomachi, Fuchu-shi, Hiroshima, 726-8610, Japan

TEL +81-(0)847-40-0561

FAX +81-(0)847-45-8911

Preface

This manual provides detailed information about how to safely and correctly use the cylinder (Y type) for a lathe.



Before starting to use this cylinder, read this manual carefully and always follow the instructions and warnings in "Important Safety Precautions" and "Precautions for Use" at beginning of the manual. Failure to follow these precautions could result in a serious accident.

Terms and Symbols Used for Safety Messages

In this manual, precautions for handling that are considered especially important are classified and displayed as shown below depending on the damage of risk including the seriousness of the harm that could result. Please sufficiently understand the meanings of these terms and follow the instructions for safe operation.

Safety Alert Symbol

The triangle is the safety alert symbol used to alert you to potential safety hazards that could result in injury or death.

 DANGER	Indicates a hazardous situation which, if you not avoided, will result in death or serious injury.
 WARNING	Indicates a hazardous situation which, if you not avoided, could result in death or serious injury.
 CAUTION	Indicates a hazardous situation which, if you not avoided, could result in minor or moderate injury.
NOTICE	Indicates instructions which, if not avoided, could result in damage to the equipment or a shortened work life.

Liability and How to Use this Manual

This product is a hydraulic device to control the operation of power chuck installed on the lathes or rotary tables. For any other applications, please contact us.

Our company will not assume responsibility for injury, death, damage, or loss resulting from not following the instructions in this manual.

There are countless things that cannot or should not be done, and it is impossible to cover all of them in this manual.

Therefore, do not perform any actions unless they are specifically allowed in this manual. If any questions related to safety arise about operation, control, inspection and maintenance which are not specified in this manual, please confirm them with our company or distributor before performing them.

Guarantee and Limitation of Liability

The guarantee period of this product is 1 year after delivery.

Use the parts delivered by Kitagawa Corporation for all the parts including consumable parts. We will not assume responsibility for injury, death, damage, or loss caused by usage of parts not manufactured by Kitagawa Corporation. Additionally, if parts other than genuine parts manufactured by Kitagawa Corporation are used, this guarantee will be completely invalid.

The chuck and cylinder from Kitagawa Corporation should be used together. If you must use a part not made by Kitagawa, check with us or our distributor to be sure it is safe to do so. We will not be responsible for injury, death, damage or loss caused by use of a chuck or cylinder made by another company unless this use has been approved by Kitagawa or its distributor.

Table of Contents

1. Structural Drawing and Parts List -----	5
1-1. Type display	
1-2. Structural drawing	
1-3. Scope of product	
1-4. Parts list	
2.  Important Safety Precautions -----	10
3. Specifications -----	17
3-1. Specification table	
4. Hydraulic Oil-----	19
5. Trial Operation-----	21
6. Proximity switch-----	23
6-1. Specifications	
6-2. Adjusting the position of a proximity switch	
7. Maintenance and Inspection-----	25
7-1. Maintenance and inspection of cylinder	
7-2. Maintenance and inspection of hydraulic unit	
7-3. List of seals to use	
8. Malfunction and Countermeasures-----	26
8-1. In the case of malfunction	
8-2. Where to contact in the case of malfunction	

For Machine Tool Manufacturers (Chapter 9)

9. Attachment-----	28
9-1. Outline drawing of attachment	
9-2. Production and attachment of cylinder adapter	
9-3. Production and attachment of draw bar	
9-4. Attachment of cylinder	
9-5. Tightening torque of cylinder attaching bolt	
10. About Hydraulic Circuit Design-----	38
11. Other Information -----	41
11-1. About standards and orders	
11-2. Information about markings of product	
11-3. About disposal	

1. Structural Drawing and Parts List

1-1. Type display

Type display as shown below

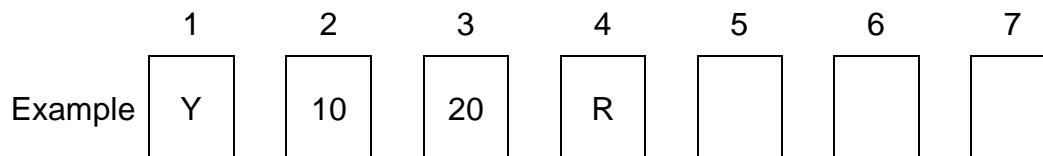

5th digit and after that are not displayed for the standard cylinders.

1. Y Abbreviated name of Y cylinders
2. 10 Nominal inside diameter of the cylinder
3. 20 Nominal piston stroke
4. R Cylinder with lock valve, relief valve
- RE Cylinder with lock valve, relief valve and proximity switch
- 5~7 Columns for special specification

1-2. Structural drawing

Y·R type

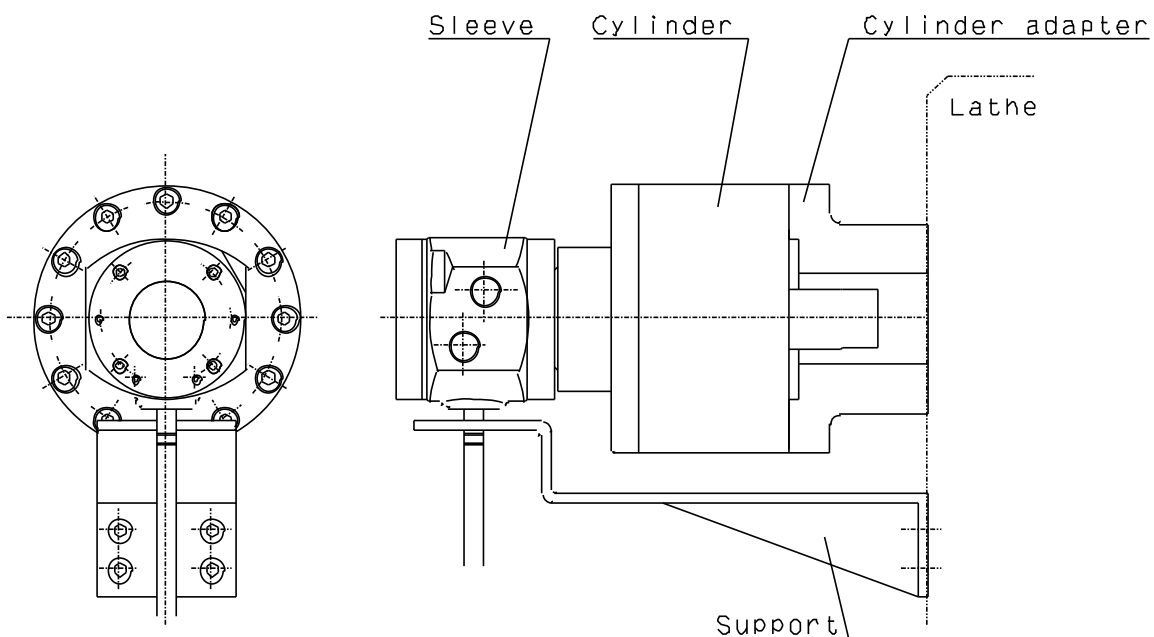

Y·RE type

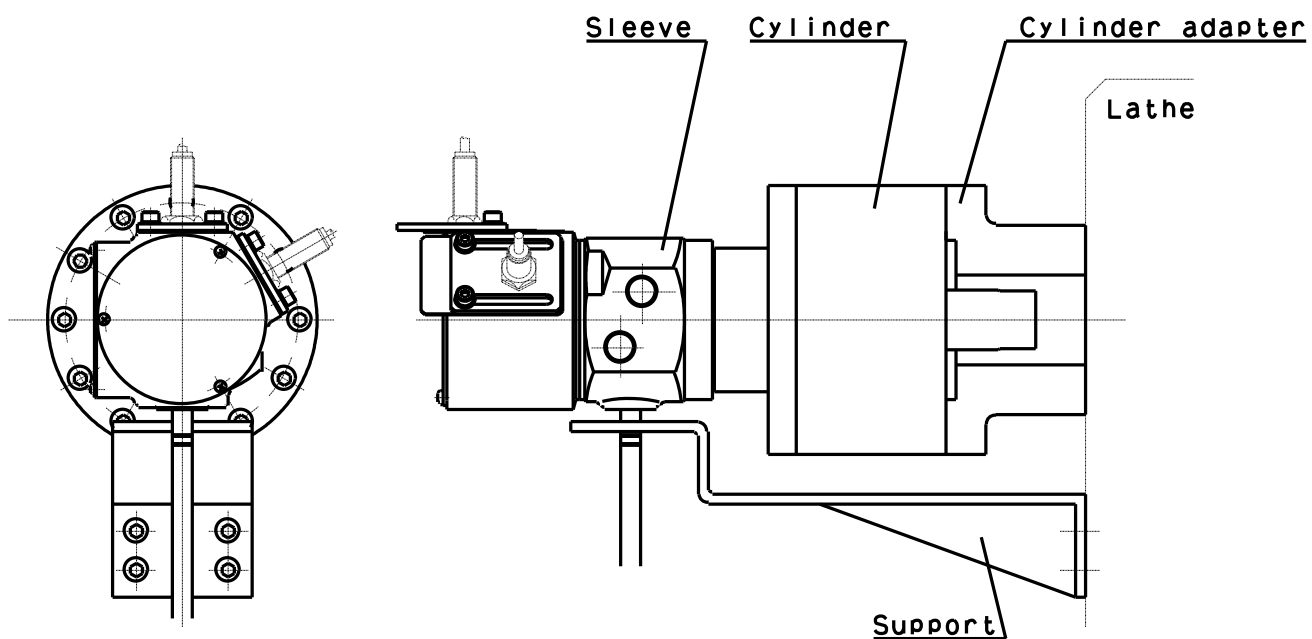

Fig. 1

Note) Proximity switch is not included.
Please prepare by yourself.

1-3. Scope of product

This instruction manual is for the cylinder part.

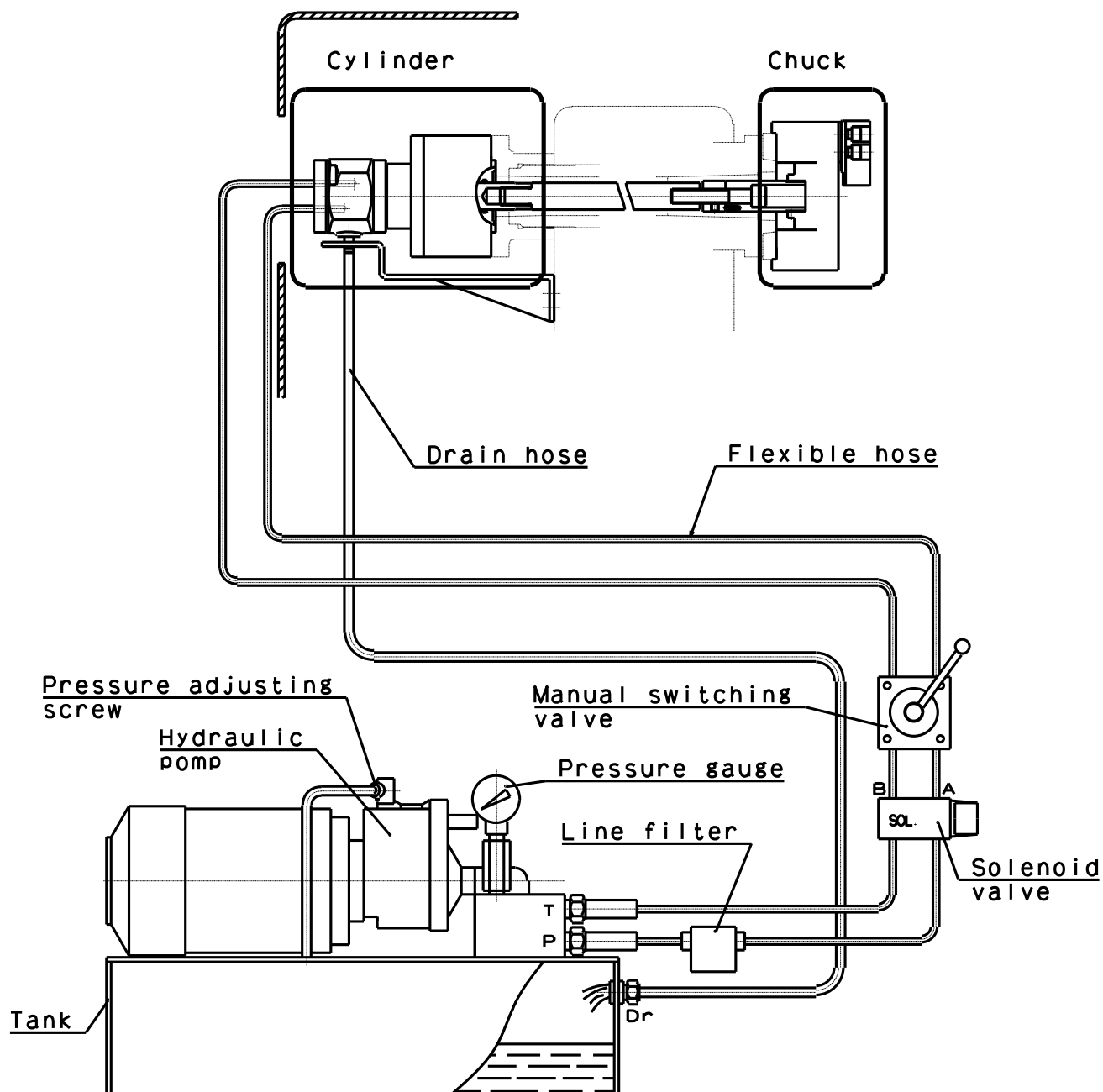

Fig. 2

! WARNING

- To prevent the work from flying, safe design, maintenance and erroneous action prevention of the hydraulic system to maintain the gripping force of the chuck is extremely important. Thoroughly read the "Important Safety Precautions" on and after page 10 in this manual.
- As for the chuck, follow the instruction manual for the chuck.

1-4. Parts list

Y·R type

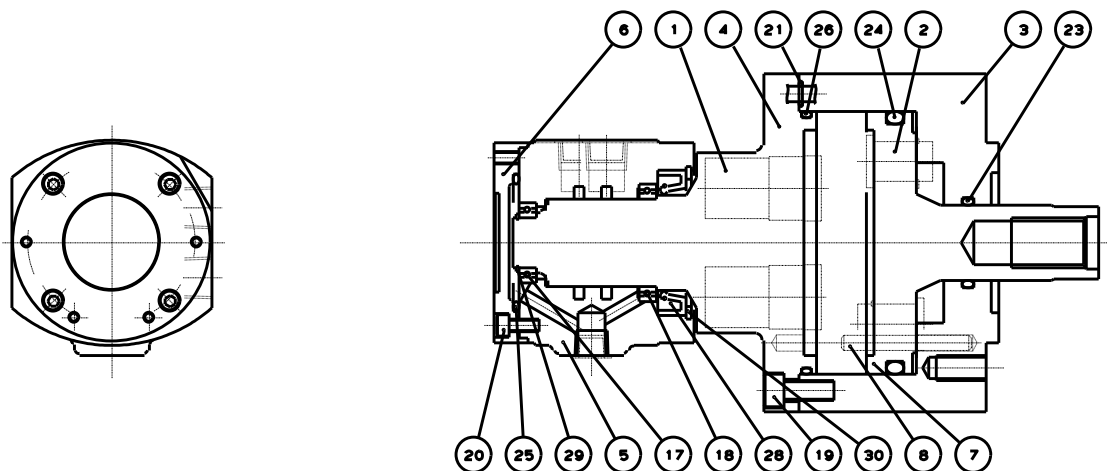

Fig. 3

Table 1

No.	Part name	Quantity	No.	Part name	Quantity
1	Lock valve	2	19	Socket head cap screw	6,12or16
2	Relief valve	2	20	Socket head cap screw	4
3	Cylinder	1	21	O-ring	1
4	Rotary valve	1	22		
5	Sleeve	1	23	O-ring	1
6	Sleeve cover	1	24	O-ring	1
7	Piston	1	25	O-ring	1
8	Guide pin	2	26	O-ring	1
9			27		
10			28	Oil seal	1
11			29	Retaining ring	1
12			30	Retaining ring	1
13			31		
14			32		
15			33		
16			34		
17	Bearing	1	35		
18	Bearing	1			

Y·RE type

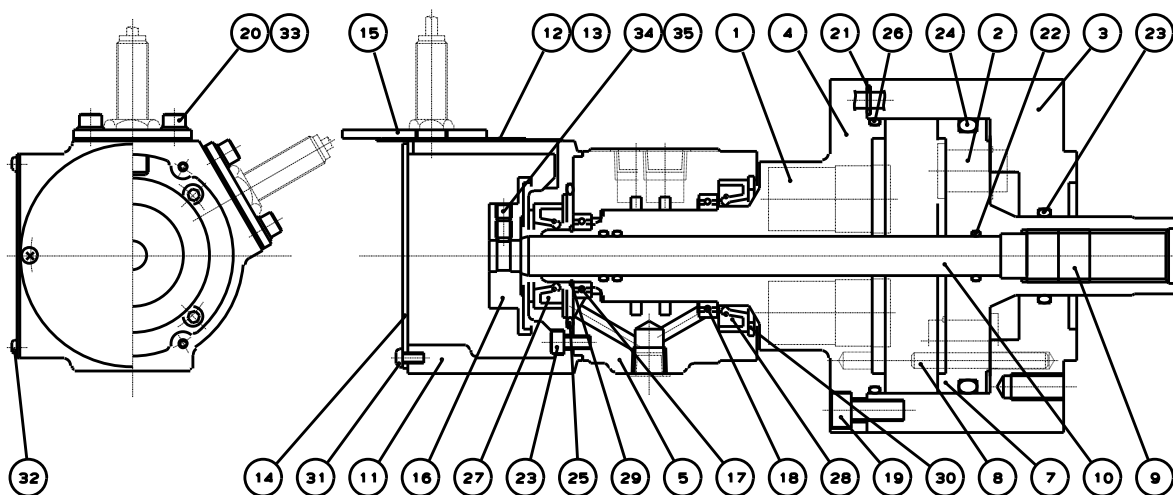



Fig. 4

Table 2

No.	Part name	Quantity	No.	Part name	Quantity
1	Lock valve	2	19	Socket head cap screw	6,12or16
2	Relief valve	2	20	Socket head cap screw	10
3	Cylinder	1	21	O-ring	1
4	Rotary valve	1	22	O-ring	3
5	Sleeve	1	23	O-ring	1
6			24	O-ring	1
7	Piston	1	25	O-ring	1
8	Guide pin	2	26	O-ring	1
9	Set screw	2	27	Oil seal	1
10	Piston bar	1	28	Oil seal	1
11	Casing	1	29	Retaining ring	1
12	Plate A	2	30	Retaining ring	1
13	Plate B	2	31	Machine screw	3
14	Cover	1	32	Machine screw	4
15	Adjusting plate	2	33	Washer	4
16	Detectable plate	1	34	Set screw	2
17	Bearing	1	35	Set screw	2
18	Bearing	1			

2. Important Safety Precautions

Important safety precautions are summarized below. Please read this section before first starting to use this product.

 **DANGER** Failure to follow the safety precautions below will result in serious injury or death.

 Turn off main power supply before attaching, inspecting or replacing cylinder, and before adding oil. **For All Users**

- The cylinder may start rotation suddenly, and a part of the body or clothing may be caught.

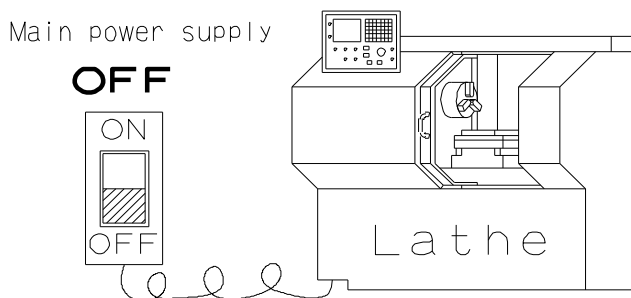

 Close door before rotating spindle. **For All Users**

- If the door is not closed, you may touch the rotating chuck or the work may fly out, which is very dangerous. (In general, the safety interlock function which allows rotation only when the door is the manual mode or the test mode)

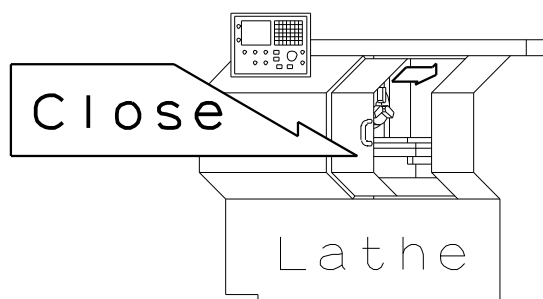

 During spindle rotation, do not turn off hydraulic pump power supply and do not operate switching valve. **For All Users**

- Cutting off hydraulic pressure causes a drop in the gripping force which could result in the work being released and flying out.
- Operating the manual switching valve or solenoid valve will lead to a drop of hydraulic pressure.

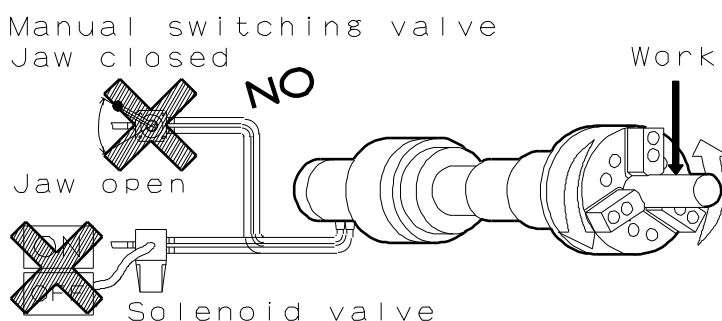

! Important Safety Precautions

! DANGER Failure to follow the safety precautions below will result in serious injury or death.



Do not allow the rotation speed of the chuck to exceed the maximum allowable speed limit.

For All Users

- If the rotation speed of the chuck exceeds the rotation speed limit, this is very dangerous as the chuck and work will fly out.

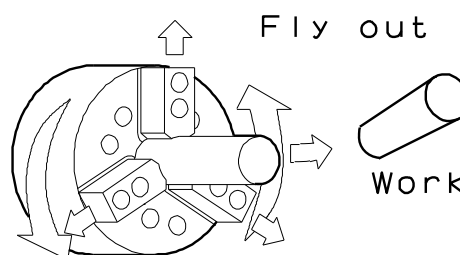

The input force of the chuck (piston thrust, pulling force of the draw bar) must not exceed the allowable maximum input force.

For All Users

- Input must match the specification of the chuck.
- Adjust the hydraulic pressure to the cylinder so that the input, which determines the gripping force of the chuck, does not exceed.
- Excessive input force can lead to breakage of the chuck, which is very dangerous, as the chuck and work can be damaged and fly out.

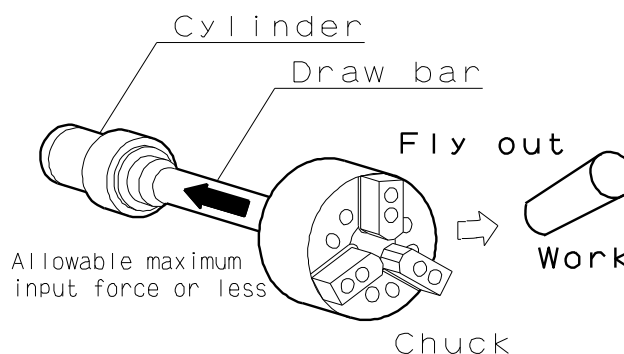

Be sure cover is attached to periphery of cylinder before operating machine. (Refer to pages 28-29)

For All Users

- This will prevent the body or clothing from being caught in the machine.

Prepare the covers that conform to the following standards.

- EN953
- EN ISO13857
- EN1088

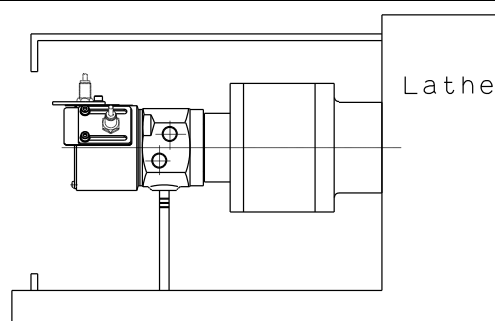



Important Safety Precautions



DANGER Failure to follow the safety precautions below will result in serious injury or death.



Always tighten the bolts at the specified torque. (Refer to pages 37)

For All Users

- If the torque is insufficient or excessive, the bolt will break, which is dangerous as the cylinder or work will fly out.
- Fix the lathe spindle or the cylinder when you tighten bolts. Your hand could slip and get injury when you work without fixing the spindle.
- You must use a torque wrench for torque control.

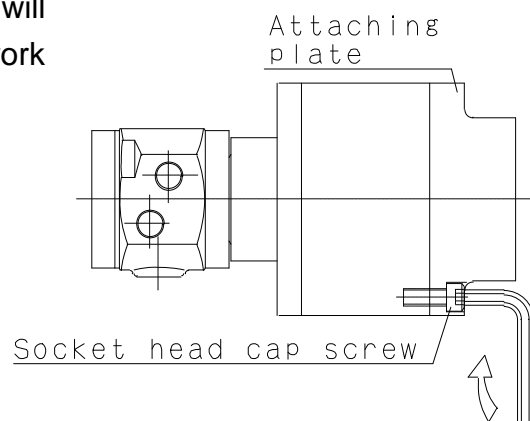

Specified torque for socket head cap screw

Bolt size	Tightening torque
M6	10 N·m
M10	58 N·m
M12	85 N·m
M16	200 N·m

※ Since the material of the cylinder is aluminum, it is 80% of the tightening torque to the bolt size specified for the hydraulic chuck of our company.

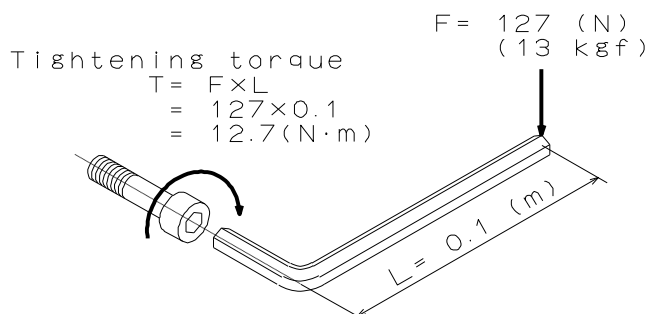

Tightening torque is moment of force when you tighten a bolt. Tightening torque= $F \times L$.



Important Safety Precautions



DANGER

Failure to follow the safety precautions below will result in serious injury or death.



Use of a chuck and cylinder that cannot be used together safely may cause the cylinder to break at high pressure resulting in the chuck and work flying out.

For All Users

- Check that the chuck and the cylinder are in the “safe combination” when using at high pressure with our company or the distributor. Especially when the cylinder of our company and a high pressure chuck of other company are combined, confirmation is necessary.
- If one of the abnormal events shown below occurs during operation, immediately stop the machine and consult with our company or the distributor.
 - The work slips.
 - Loss of accuracy.
 - The work begins to chatter.
 - The machine's vibration significantly increases.

The gripping force does not rise even if hydraulic pressure is raised.

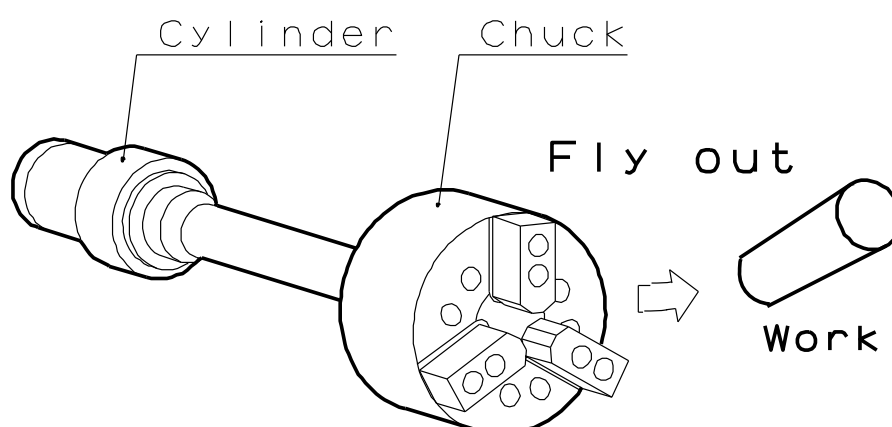



Important Safety Precautions



DANGER Failure to follow the safety precautions below will result in serious injury or death.



Provide sufficient strength for the draw bar (Refer to pages 32-33).

Provide sufficient screw depth for the draw bar.

Firmly tighten the draw bar.

Apply adhesive to the thread part of the draw bar and screw it in at the specified torque.

For Machine Tool Manufacturers

- If the draw bar break, the gripping force is instantly lost and this is dangerous as work will fly out.
- If the screw depth of the draw bar is insufficient, the screw will break and the gripping force will be lost instantly, and this is dangerous as work will fly out.
- If the draw bar is unbalanced, excessive vibration could occur breaking the screw and resulting in the gripping force being lost and the work flying out.
- When screwing the draw bar, piston to the end of the pull side stroke.
- If the engagement of the screw of the draw bar is loose, vibration may occur resulting in breakage of the screw. If the screw breaks, the gripping force will be lost instantly, which is dangerous as the work will fly out.
- When the screw is loosened, the jaw stroke of the chuck becomes shorter and this is very dangerous as the work will fly out.

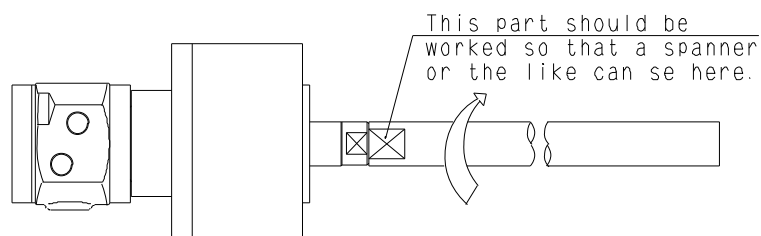
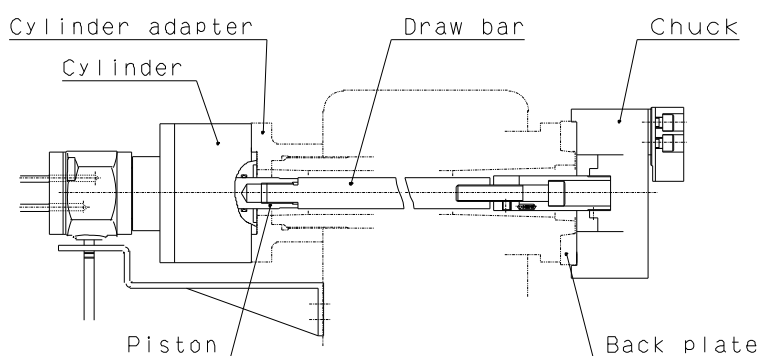

Type	Tightening torque
Y0715R / RE01C	100 N•m
Y1020R / RE47	100 N•m
Y1225R / RE47	180 N•m
Y1530R / RE47	355 N•m
Y2035R / RE47	620 N•m

! Important Safety Precautions

! WARNING Failure to follow the safety precautions below could result in serious injury or death.



Do not modify the cylinder.

For All Users

- Doing so may damage the cylinder and cause oil leakage which could result in a fire. And if the hydraulic oil leaks, the gripping force of the chuck will lower and the work may fly out, which is dangerous.
- Do not attach additional machining such as screws.
- Do not detach parts of the cylinder from the cylinder.



Do not rotate the cylinder without hydraulic pressure.

For All Users

- Doing so could cause seizing inside the cylinder, leading to a drop in the gripping force of the chuck. This is dangerous as work will fly out.



Periodically add hydraulic oil.

Turn off power and use designated hydraulic oil. (Refer to page 19)

For All Users

- If supplying of the hydraulic oil is insufficient, the operation speed may lower and the thrust force will become insufficient resulting in a drop in the gripping force of the chuck, which is dangerous as the work may fly out.
- Use abrasion resistant and deforming hydraulic oil.

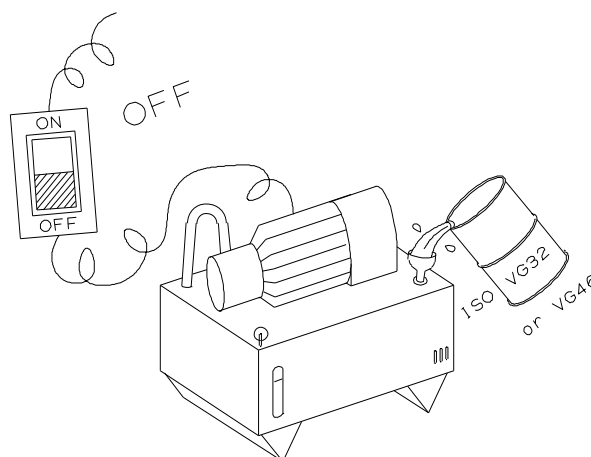

Important Safety Precautions

 **WARNING** Failure to follow the safety precautions below could result in serious injury or death.

 Assemble piping after completely removing the dust inside the pipe. Add a filter of 20µm or less into the pressure supplying line(P). **For All Users**

- Failure to do so could cause oil leakage and may result in a fire.
- Maintain the function of the incorporated lock valve and relief valve, and prevent seizing due to foreign matter.
 - If the function of the lock valve lowers, this is dangerous as the work will fly out when the hydraulic pressure suddenly lowers due to blackout or malfunction of the hydraulic pump, etc.
 - If the function of the relief valve lowers, the volume of the filled hydraulic oil changes causing an increase in pressure, which is dangerous resulting in malfunction.
 - If seizing is caused by foreign matter, the gripping force of the chuck will lower, which is dangerous as the work will fly out.

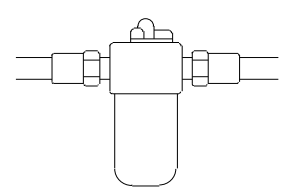

Filtering Precision 20µm or less

 Do not operate the machine after drinking alcohol or taking medication. **For All Users**

- Dangerous since these lead to operation mistakes and misjudgment.

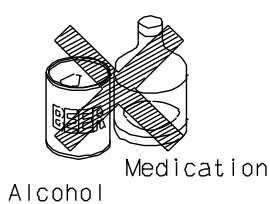

 Do not operate the machine wearing gloves, a necktie, and other loose clothing or jewelry. **For All Users**

- Dangerous since it will be caught.

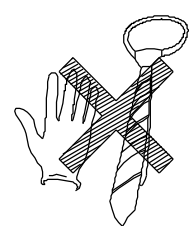

 Do not attach the other than parts manufactured by Kitagawa Corporation to the cylinder. (Refer to pages 8-9, Fig.3-4) **For Machine Tool Manufactures**

- Doing so may damage the cylinder and cause oil leakage which could result in a fire. And if the hydraulic oil leaks, the gripping force of the chuck will lower and the work may fly out, which is dangerous.

3. Specifications

3-1. Specifications table

Y·R type (Cylinder with lock valve, relief valve)

Table 3

Type		Y0715R	Y1020R	Y1225R	Y1530R	Y2035R	
Piston stroke	mm	15	20	25	30	35	
Piston surface area	cm ²	Push	44	86	122	176	314
		Pull	37	79	113	160	290
Piston maximum thrust force	kN	Push	16.6	32	46	66	117
		Pull	13.9	29	42	60	108
Maximum operating hydraulic pressure	MPa	4	4	4	4	4	
Maximum rotation speed	min ⁻¹	6000	6000	6000	5500	5500	
Mass	kg	4.0	7.1	10.0	13.5	22.0	
Moment of inertia	kg·m ²	0.003	0.013	0.023	0.048	0.098	
Drain amount	ℓ/min	0.8	0.8	0.8	0.8	0.8	
Balance quality	G6.3						
Storing temperature / Operating temperature	-20 ~ +50 °C / -10 ~ +40 °C						

Y·RE47 type (Cylinder with lock valve, relief valve, proximity switch)

Table 4

Type		Y0715RE01C	Y1020RE47	Y1225RE47	Y1530RE47	Y2035RE47	
Piston stroke	mm	15	20	25	30	35	
Piston surface area	cm ²	Push	42	84	120	174	312
		Pull	37	79	113	160	290
Piston maximum thrust force	kN	Push	15.9	31	45	65	117
		Pull	13.9	29	42	60	108
Maximum operating hydraulic pressure	MPa	4	4	4	4	4	
Maximum rotation speed	min ⁻¹	6000	6000	6000	5500	5500	
Mass	kg	4.5	7.6	10.5	14.0	22.5	
Moment of inertia	kg·m ²	0.003	0.013	0.023	0.048	0.098	
Drain amount	ℓ/min	0.8	0.8	0.8	0.8	0.8	
Balance quality	G6.3						
Storing temperature / Operating temperature	-20 ~ +50 °C / -10 ~ +40 °C						

Note 1) The drain amount is a value when the hydraulic pressure is 3.0 MPa, and the oil temperature is 50°C.

Note 2) How to obtain the piston thrust force

$$\begin{array}{rcccl} \text{Operating} & & \text{Piston} & & \text{Operating} \\ \text{Piston} & & \text{Maximum} & & \text{hydraulic pressure(MPa)} \\ \text{thrust force} & = & \text{Thrust force} & \times & \frac{\text{hydraulic pressure(MPa)}}{\text{Maximum operating}} \\ \text{(kN)} & & \text{(kN)} & & \text{hydraulic pressure(MPa)} \end{array} \quad \begin{array}{l} - \\ - \end{array} \quad \begin{array}{l} 0.25 \\ 0.25 \end{array}$$

Note 3) When storing this product, the product should be subjected to the antirust treatment and stored in a place free from wetting, condensation, or freeze.

4. Hydraulic Oil

- To keep good operation of the cylinder, it is recommended to use hydraulic oil with a viscosity of 32cSt at 40°C. (ISO VG32 equivalent product)
- Replace the hydraulic oil about once every six months.
- The characteristics of hydraulic oil influences the heating, drain amount and acting speed of the cylinder, therefore, control it according to the instruction manual for the hydraulic unit.

WARNING

- Turn off the power source and supply designated hydraulic oil. Insufficient oil supply decreases the acting speed, causes thrust force insufficiency resulting in a drop in the chuck gripping force, which could allow the work to fly out. Use abrasion resistant and deforming hydraulic oil. Add a filter of 20µm or less in the pressure supply line(P) to maintain the function of the cylinder and to prevent seizing caused by foreign matter.

NOTICE

- If high speed rotation is continued, the oil temperature will rise, which could rapidly a high temperature, it will rapidly aggravate deterioration of the sealing materials and deterioration of the hydraulic oil. Use a cooler to keep the oil temperature at 60°C or lower.

<Example>

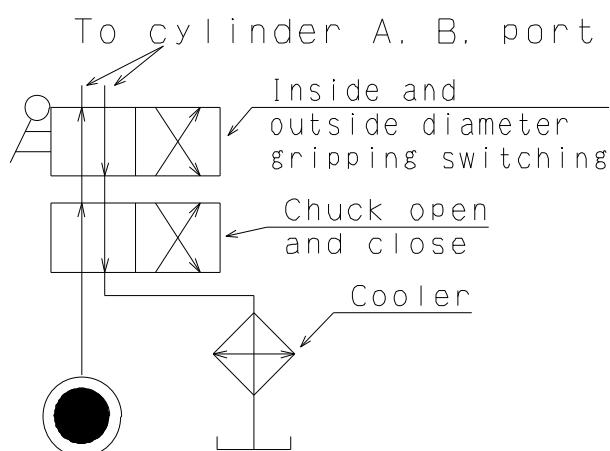

Fig. 5

※ Keep the back pressure extremely low in this case as well.

Safety information about hydraulic fluid and anti-rust oil**Applicable range**

- Hydraulic fluid sealed in the product at the delivery.
- Antirust agent applied to the product at the delivery.

First aid measures

After inhalation: Remove victim to fresh air. If symptoms persist, call a physician.

After contact with skin: Wash off with mild cleaners and plenty of water. If symptoms persist, call a physician.

After contact with eyes: Rinse with plenty of water. If symptoms persist, call a physician.

After ingestion: If large amounts are swallowed, do not induce vomiting. Obtain medical attention.

- Please refer to each MSDS about the hydraulic fluid and the anti-rust oil which you prepared.

5. Trial Operation

Read safety precautions starting on page 10 before performing trial operation.

- (1) Check that the power voltage is at the specified voltage.
- (2) Set the pressure adjusting handle to the lowest state during trial operation, and check the turning direction of the pump in inching (shortly turn on and off the switch). When it is rotating in the reversed direction, change the connection of 2 cables out of the 3 cables.
- (3) As for the operating pressure for chucking, first lower to the lowest pressure, and then set to low pressure at which the chucking action is possible (0.35-0.5MPa) to check the following.
 - Is it operating smoothly?
 - Is the operating direction correct? (Opening and closing direction of the chuck)
 - Is the operating stroke appropriate? (Jaw stroke of the chuck)
 - Is there any oil leakage with each piping?

If they are normal, gradually raise the operating pressure up to the rated pressure while checking the items specified above.

At this point, check that the drainage is flowing smoothly.
- (4) Rotate the lathe spindle by setting the rotation speed to the minimum. If there is no run-out of the cylinder or no abnormalities in the support and piping, gradually raise the rotation speed.

If the rotation vibration is too excessive, run-out of the adapter must be inspected again.
- (5) If the oil temperature is low (20-30°C) or less, run it in at about 1/3 of the maximum rotation speed.

NOTICE

- When the ambient temperature of the cylinder suddenly rises, for example, thermal effect is received from heating of the pulley, etc., or when there is a special heat generation source around the cylinder, the cylinder charged pressure rises and then the cylinder may stop operation, if it is continuously operated for a long period of time without switching operation, since a lock mechanism is built in such a phenomenon occurs more frequently especially at the time of running in, therefore, frequently reciprocate the piston.

< Treatment when the cylinder cannot be operated >

○ Regardless of trial operation or normal operation, when the cylinder cannot be operated, try the operations specified below.

1. When the lathe spindle is rotating, stop rotation.
2. Turn the pressure adjusting handle of the pressure regulation valve for the chuck setting pressure (cylinder setting hydraulic pressure) at the hydraulic unit part, and raise the chuck setting pressure for about 0.5 MPa and repeat switching over the operation selecting switch of the cylinder to check the operation of the cylinder.
3. If the operation inability still continues, raise the chuck setting pressure additionally (about 0.5 MPa at a time), and repeat the operation in the same manner as item (2), to check the action of the cylinder. In this case, the limit of the pressure raising is up to 30% increase of the maximum operating hydraulic pressure.
When the cylinder operation is recovered, bring back the preset chuck pressure to the normal level.
4. If the cylinder cannot be operated even after the chuck setting pressure is raised to the maximum and the operation specified in the above item (3) is repeated several times, return to the chuck setting pressure, turn off the power supply, cool down the temperature of the cylinder surface to be almost the same as the room temperature, and then repeat the operations specified in the above items (2) and (3) to check the operation of the cylinder.
The cylinder can be cooled down more quickly by forcibly blowing air to the cylinder using an air gun, etc.
5. If the cylinder cannot be operated even after cooling down, loosen the draw screw on the chuck side and remove the connection, and then check the operation of the cylinder.

< Usage >

This product is a hydraulic device to control the operation of power chuck installed on the lathes or rotary tables.

The piston moves forward and backward by supplying hydraulic pressure to the cylinder. By this, the linked jaws of the power chuck move toward the closing side to grip the workpiece, so that the workpiece is clamped during the machining. After the machining, the jaws move toward the open side to allow the workpiece to be removed.

6. Proximity switch

6-1. Specification

- Y-RE type cylinder can be installed two pieces proximity switches for checking electrically the piston operation of a cylinder or for the detection of chucking/unchucking of a workpiece.

The proximity switch is not included, so please prepare it by yourself by referring to the specifications of the proximity switch below.

Table 5

Type	BES M12MI-NSC20B-BV02 (BALLUFF)
Voltage	24V DC
Leakage current	200mA or less
Operation style	NPN

Table 6

Type	BES M12MI-NSC20B-BV02 (BALLUFF)
OP2	BLACK
+V	BROWN
0V	BLUE
OP1	BLACK

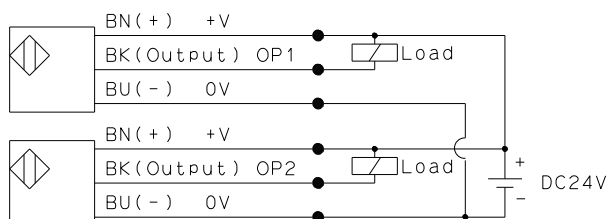

Fig. 6

6-2. Adjusting the position of a proximity switch

Read following instruction when you adjust the proximity switch. (Fig.7)

- ① Loosen the machine screw [31], then remove the cover [14].
- ② Loosen the socket head cap screw [20] that fix the adjusting plate [15].
- ③ Unclamp the chuck.
- ④ Install one proximity switch on the outer surface of the casing [11], passing through the adjusting plate [15], and make it approach to the detectable plate [16] until the LED of proximity switch lights up. At this time, adjust the screw of proximity switch so that the distance between proximity switch and outside diameter end of detectable plate [16] is about 1 mm, and slide to adjust the adjusting plate [15] in the axial direction.
- ⑤ Tighten the socket head cap screw [20] to fix the adjusting plate [15].
- ⑥ Grip the workpiece.
- ⑦ For another proximity switch proceeds in the same way as it is described from point 4 and 5.
- ⑧ Confirm whether LED lights up by opening and closing the chuck several times.
- ⑨ Tighten the machine screw [31] to fix the cover [14].

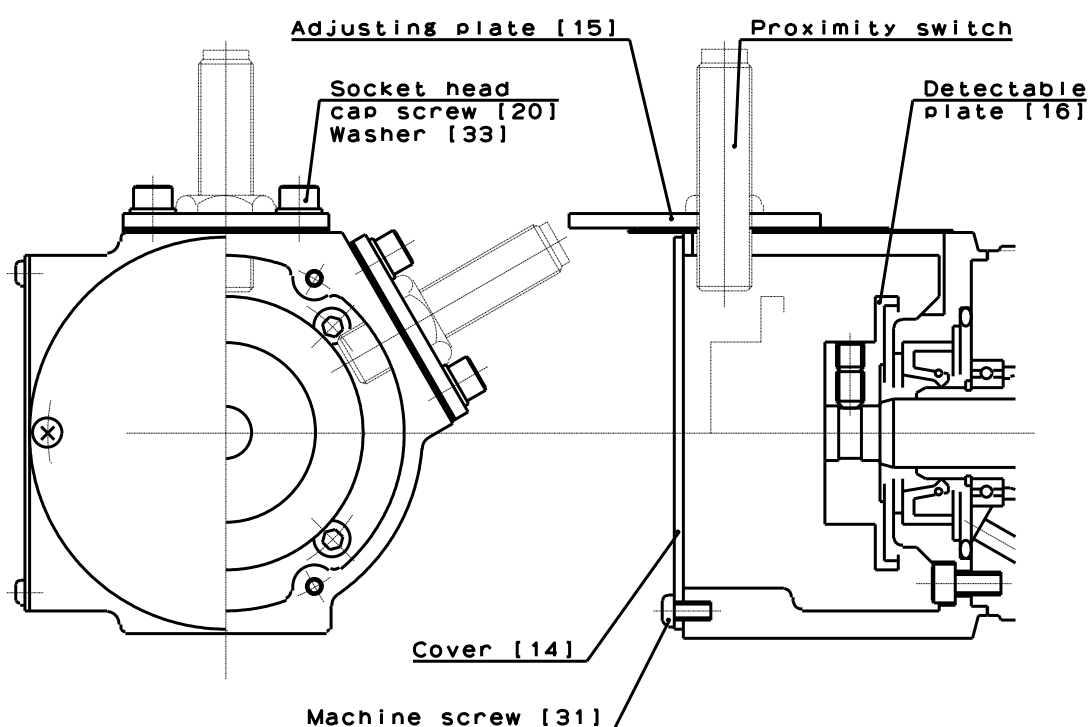

Fig.7

7. Maintenance and Inspection

7-1. Maintenance and inspection of the cylinder

If any malfunction occurs, return cylinder to our company for repair. If it is disassembled and reassembled at a place other than our company, it may not function correctly as well as cause precision failure.

7-2. Maintenance and inspection of hydraulic unit

- Clean the suction strainer every 2 to 3 months.
- Replace the hydraulic oil about once every six months.

7-3. List of seals to use (Refer to Fig.3-4)

Table 7

No.	Part name	Y0715R	Y1020R	Y1225R	Y1530R	Y2035R	Y0715RE01C	Y1020RE47	Y1225RE47	Y1530RE47	Y2035RE47	Quantity
21	O-ring	JIS B 2401 P8	JIS B 2401 P8	JIS B 2401 P10	JIS B 2401 P10	JIS B 2401 P10	JIS B 2401 P8	JIS B 2401 P8	JIS B 2401 P10	JIS B 2401 P10	JIS B 2401 P10	1
22	O-ring	-	-	-	-	-	JIS B 2401 P15	JIS B 2401 P15	JIS B 2401 P15	JIS B 2401 P15	JIS B 2401 P15	3
23	O-ring	JIS B 2401 P30	JIS B 2401 P30	JIS B 2401 P35	JIS B 2401 P45	JIS B 2401 P55	JIS B 2401 P30	JIS B 2401 P30	JIS B 2401 P35	JIS B 2401 P45	JIS B 2401 P55	1
24	O-ring	JIS B 2401 P65	JIS B 2401 P95	JIS B 2401 P115	JIS B 2401 P140	JIS B 2401 P185	JIS B 2401 P65	JIS B 2401 P95	JIS B 2401 P115	JIS B 2401 P140	JIS B 2401 P185	1
25	O-ring	JIS B 2401 G50	JIS B 2401 G50	JIS B 2401 G50	JIS B 2401 G50	JIS B 2401 G50	JIS B 2401 G50	JIS B 2401 G50	JIS B 2401 G50	JIS B 2401 G50	JIS B 2401 G50	1
26	O-ring	JIS B 2401 G70	JIS B 2401 G100	JIS B 2401 G120	JIS B 2401 G145	AS 568-264	JIS B 2401 G70	JIS B 2401 G100	JIS B 2401 G120	JIS B 2401 G145	AS 568-264	1
27	Oil seal	-	-	-	-	-	JIS B 2402 S20 40 11	JIS B 2402 S20 40 11	JIS B 2402 S20 40 11	JIS B 2402 S20 40 11	JIS B 2402 S20 40 11	1
28	Oil seal	JIS B 2402 S38 58 11	JIS B 2402 S38 58 11	JIS B 2402 S38 58 11	JIS B 2402 S38 58 11	JIS B 2402 S38 58 11	JIS B 2402 S38 58 11	JIS B 2402 S38 58 11	JIS B 2402 S38 58 11	JIS B 2402 S38 58 11	JIS B 2402 S38 58 11	1

8. Malfunction and Countermeasures

8-1. In the case of malfunction

Check the points specified below again and take measures.

Table 8

Defective	Measures
Piston Operation Inability	Check that the hydraulic pressure is operating by the motion of the flexible hose, etc.
	Check that there are no mistakes in piping.
	Try operations when operation inability specified in the items of the trial operation.
Cylinder Thrust Force Insufficiency	Check that the pressure is as specified at the cylinder pipe inlet by attaching a pressure gauge near the inlet of the cylinder.
	Wearing of the O-ring inside is possible when the flow rate of the returning side pipe or the drain is more than usual.
Temperature Rise	Check that the viscosity of the hydraulic oil is as designated.
	Replenish the hydraulic oil inside the tank if it is low.
	When the room temperature is high and the radiation effect of the tank is bad, control the oil temperature using a cooler or a fan, etc.
Pump noise	Do not suck air.
	Replenish the hydraulic oil inside the tank if it is low.
	If a large amount of dirt is deposited inside the tank, or when the hydraulic oil is deteriorated, the pump may be worn out abnormally, and it will be necessary to repair the pump.
Oil leakage from oil seal	Provide a stream slope, without air pockets, and no back pressure must be applied.
	Return the drainage onto the surface of the oil of the hydraulic unit .
	Check that the air breather of the hydraulic unit is not clogged.



- If the chuck failed due to a seizure or breakage, remove the chuck from the machine, following the disassembly steps in the chuck instruction manual, and then remove the cylinder by the reverse steps of "9. Attachment" after page 28. When the jaws and covers cannot be removed due to a blockage of workpiece, do not disassemble forcibly but please contact us or our agent.
- If these countermeasures do not correct the problem or improve the situation, immediately stop using the machine. Continuous use of a broken product or a defective product may cause a serious accident by the cylinder or the work flying out.
- Only experienced and trained personnel should do repairs and fix malfunctions. Repair of a malfunction by a person who has never received instruction from an experienced person, the distributor or our company may cause a serious accident.

8-2. Where to contact in the case of malfunction

In the case of malfunction, contact the distributor where you purchased the product or our branch office listed on the back cover.

For Machine Tool Manufacturers

Following pages are described for machine tool manufacturers (personnel who attach a cylinder to a machine). Please read following instruction carefully when you attach or detach a cylinder to machine, and please sufficiently understand and follow the instructions for safe operation.

9. Attachment

9-1. Outline drawing of attachment

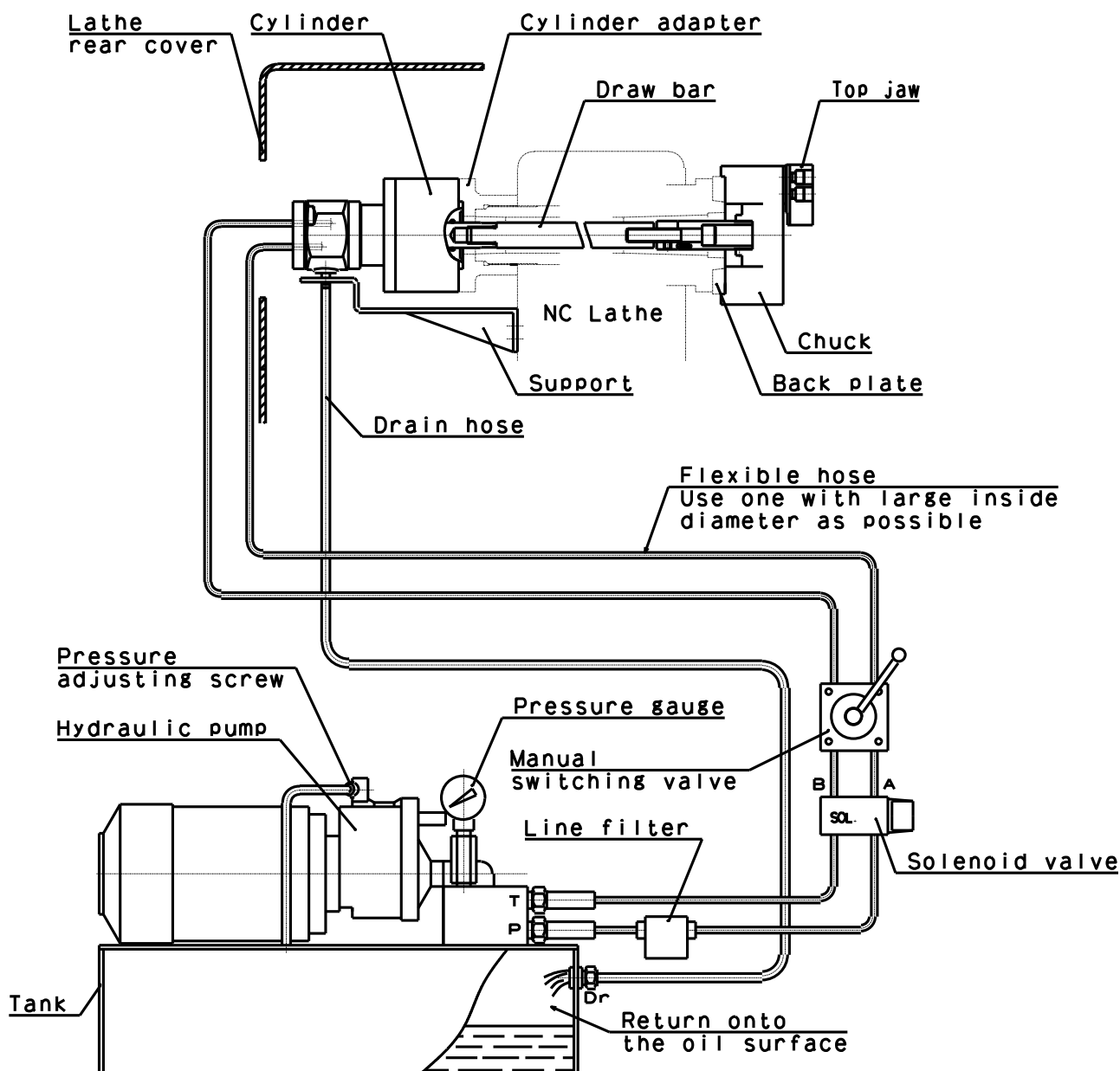

Fig. 8

- Attach the manual switching valve at a position where it is easy to operate for the attaching equipment.
- Install the hydraulic unit at a position where the drain hose is not kinked and the needle of the pressure gauge is easily read.
- Use a pipe inside diameter as large as possible.

 **DANGER**

- **When other actuators are operated by the same hydraulic pressure source as the cylinder for chuck, be sure that a pressure drop of the cylinder does not occur during use. A hydraulic pressure drop leads to a drop in the gripping force which could allow the work to fly out.**
- **The drain hose will ensure no back pressure.**
- **The end of the hose is physically above the oil level. (Refer to Fig.8)**
- **If the hydraulic oil stagnates inside the cylinder, oil leakage occurs, which may cause a fire.**

 **WARNING**

- **Install after removing the dust inside the pipe completely.**
- **Add a filter to the pressure supply line(P). If foreign matters gets inside the cylinder, this is dangerous since the rotation valve of the cylinder will seize, the hose will tear off, and the cylinder will rotate. This is also dangerous as the work will fly out.**
- **Always use a flexible hose for the hydraulic piping to the cylinder, and the bending force or tensile force of the pipe must not be applied to the cylinder. Use a pipe inside diameter as large as possible and keep the piping length as short as possible.**

NOTICE

- Provide an air passage behind the cylinder or a window about the size of the sleeve on the lathe rear cover for the hot air generated from the cylinder to escape to the outside.

9-2. Production and attachment of cylinder adapter

NOTICE

- Attach with the surface run-out of the cylinder adapter and the run-out of the spigot joint at 0.005 mm or less. (Fig. 10) Large run-out causes vibration and shortens the life of the cylinder significantly.

- Bring the cylinder as close to the lathe spindle support as possible. The attaching method of the cylinder adapter and the measuring method of run-out are illustrated in the drawings below. (Fig. 9, Table 9)
- Never fail to provide a setscrew to prevent loosening of the cylinder adapter. (Fig. 10)

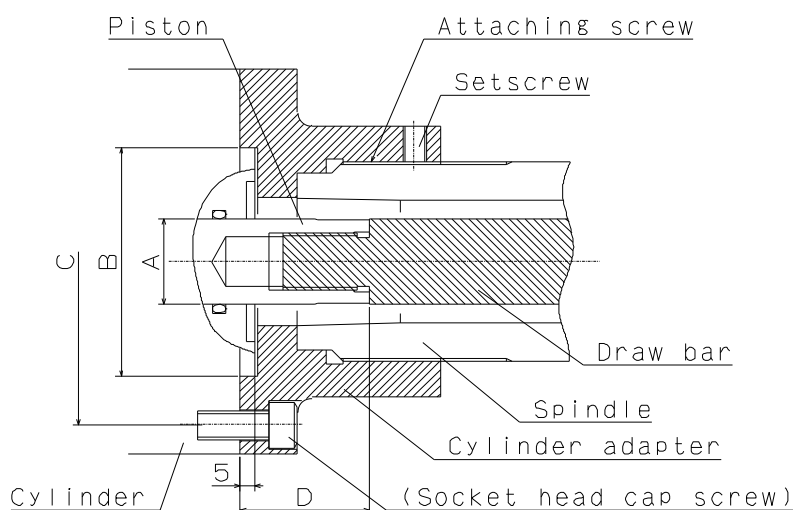

Cylinder adapter attaching part

Fig. 9

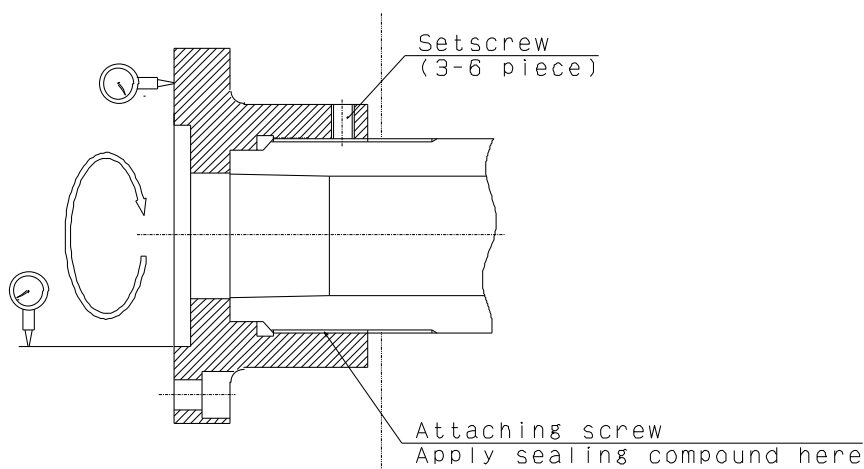

Run-out measurement of the cylinder adapter

Fig. 10

Table 9

(Unit: mm)

Type	ϕ A (F7)	ϕ B	ϕ C	D (MAX)	Socket head cap screw
Y0715R Y0715RE01C	30	65	90	46	6-M6
Y1020R Y1020RE47	30	80	100	45	6-M10
Y1225R Y1225RE47	35	110	130	51	6-M12
Y1530R Y1530RE47	45	110	130	56	12-M12
Y2035R Y2035RE47	55	120	145	69	12-M16

9-3. Production and attachment of draw bar

- Determine the length of the draw bar as shown below.
- When screwing the draw bar into the piston, screw in a state that the piston comes inside.



- Sufficiently degrease and apply adhesive on the thread part of the piston and the thread part of the draw bar, and then screw in and tighten.
- If the screw is loose, the jaw stroke of chuck will shorten, which could allow the work to fly out.

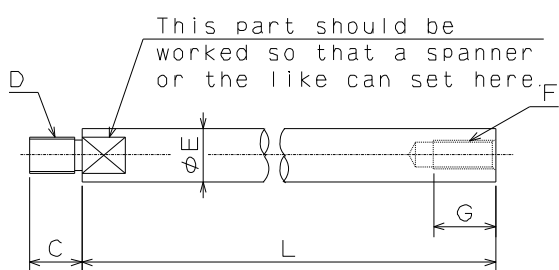

Fig. 11

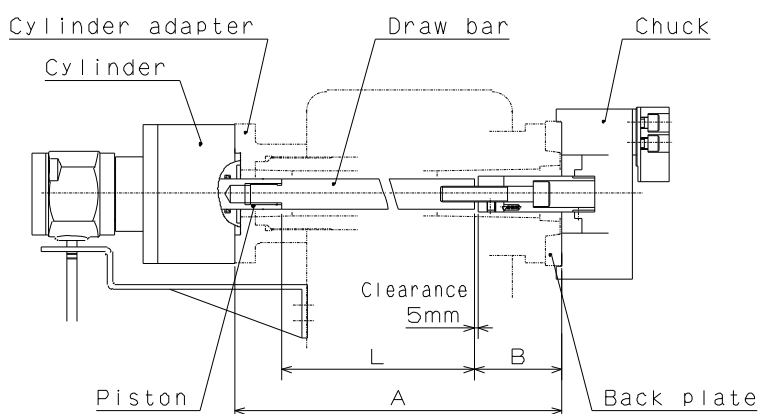

Fig. 12

Table 10

Type	Chuck	C	D	min E	F	min G	L	Remarks
Y0715R	N-04	30	M20	30	M10	25	A-B-46	N-04:L=A-54
Y0715RE01C	N-05				M12			35
Y1020R	N-06	30	M20	30	M16	35	A-B-45	N-06:L=A-131.5
Y1020RE47								
Y1225R	N-08	35	M24	35	M20	35	A-B-51	N-08:L=A-162
Y1225RE47	N-10							N-10:L=A-189
Y1530R	N-12	40	M30	40	M20	35	A-B-56	N-12:L=A-194
Y1530RE47								
Y2035R	N-15	50	M36	50	M30	45	A-B-69	N-15:L=A-143
Y2035R	N-18							N-18:L=A-131
Y2035RE47	N-21							N-21:L=A-136
	N-24							N-24:L=A-136

The dimension L in Fig. 11 is determined from the distance A between the cylinder adapter and the back plate.

Example) In the case of N-08, Y1225R, the cylinder adapter and back plate distance A = 800,

The total length of the draw bar is to be $L = A - 162 = 800 - 162 = 638$.

At the time of the screw process of the dimension C, the precision is to be JIS 6H and 6h, 6g matching the screw of the piston of the cylinder. Pay attention so that the thread parts on both ends and the outer periphery do not swing or become unbalanced.



- **Provide sufficient strength for the draw bar. If the draw bar is broken due to insufficiency of the strength, the gripping force will be lost instantly, which is dangerous as the work will fly out.**
 - Material with the tensile strength 580MPa (58kgf/mm²) or more must be used for the draw bar.
 - The personnel who designed draw bar must judge whether the strength of the draw bar is sufficient for the usage conditions.
 - The dimensions and materials specified in this manual do not guarantee that the draw bar will not break under every usage condition.
- **If the screw-in depth of the draw bar to the draw screw is insufficient, the screw will break and the gripping force will be lost instantly, which is dangerous as the work will fly out.**
- **If the draw bar is unbalanced, vibration occurs, the screw is broken and the gripping force will be lost instantly, which is dangerous as the work will fly out.**
- **If the engagement of the screw of the draw bar is loose, vibration may occur resulting in breakage of the screw. If the screw breaks, the gripping force will be lost instantly, which is dangerous as the work will fly out.**

9-4. Attachment of cylinder

- When removing/installing the cylinder, use a lifting belt and perform as follows. (Fig.13)
 1. To lift up the cylinder, engage a lifting belt with the draw bar and lift up the cylinder while supporting it.
 2. Insert the draw bar into the spindle.
 3. When a lifting belt comes close to the spindle, shift the lifting belt toward the cylinder.
 4. When the draw bar has entered the spindle sufficiently, re-engage a lifting belt with the cylinder body and fit the cylinder closely to the spindle and then install the cylinder with the cylinder mounting bolts.

Detach in the reverse procedures of attachment.

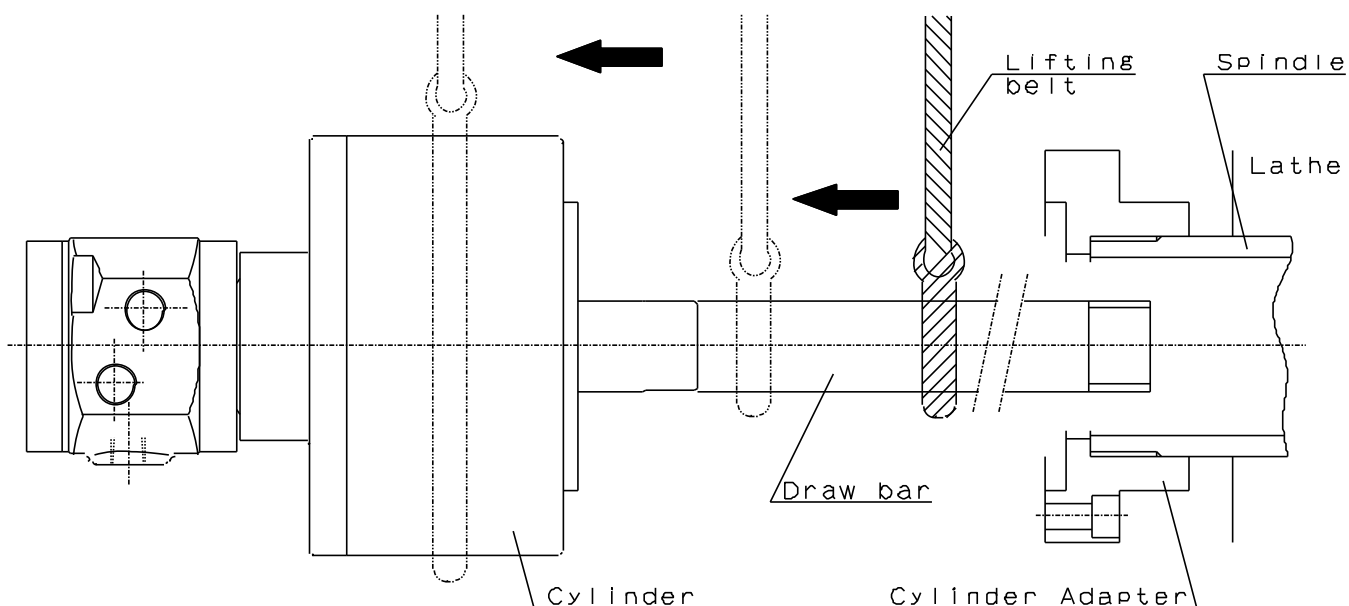

Fig.13

CAUTION

- Use a lifting belt when attaching and detaching the cylinder to and from the machine, as there is a danger of injury or damage if the cylinder drops.
- Use the belt in the center of gravity not to lose the balance, and lift the draw pipe slowly. If balance is bad, the belt slips, and the cylinder drops, and there is the injury danger such as blows.

NOTICE

- To prevent the sleeve of the cylinder from rotating, provide a support by utilizing the screw of the sleeve.
- After attaching the support to the lathe, provide clearance between the protrusion and the support so that force is not applied to the sleeve.

- Arrange the drain hose to come back to the above of oil tank surface of the hydraulic unit. (Fig.8) If the drain hose is connected to T-port such as valve block, etc., the oil seal of cylinder will damage because backpressure is applied to the hose.
- As for the run-out when attaching the cylinder, attach the cylinder while keeping the vertical run-out of the sleeve rear end and the cylinder periphery at the standard value specified in the table 11 or lower when rotation stop of the sleeve is applied and the spindle is rotated.

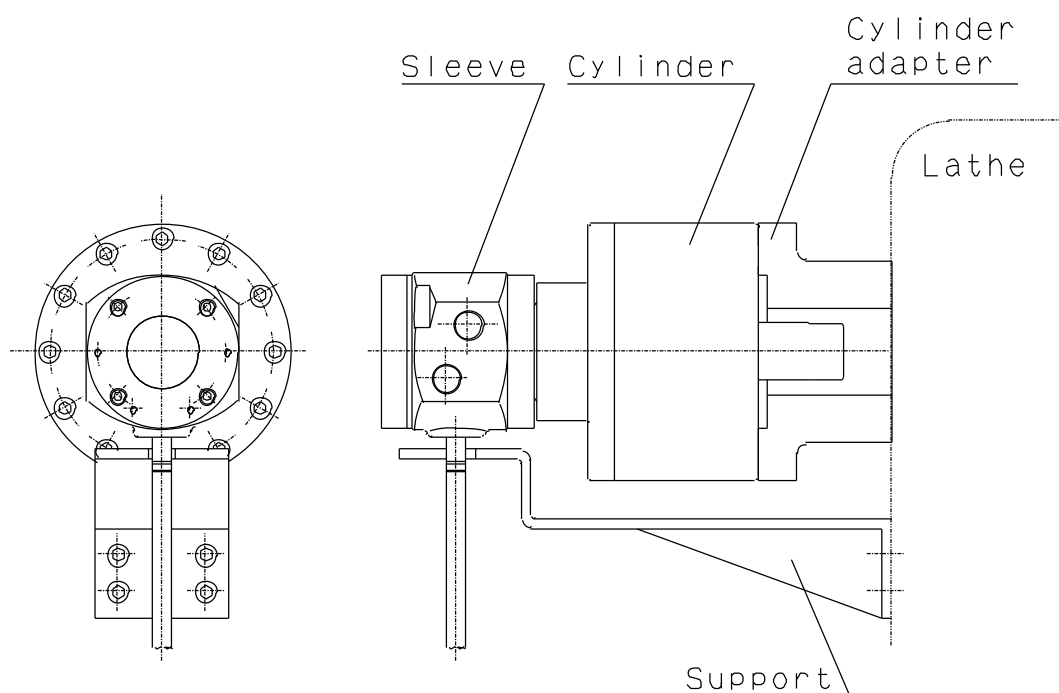

Fig. 14

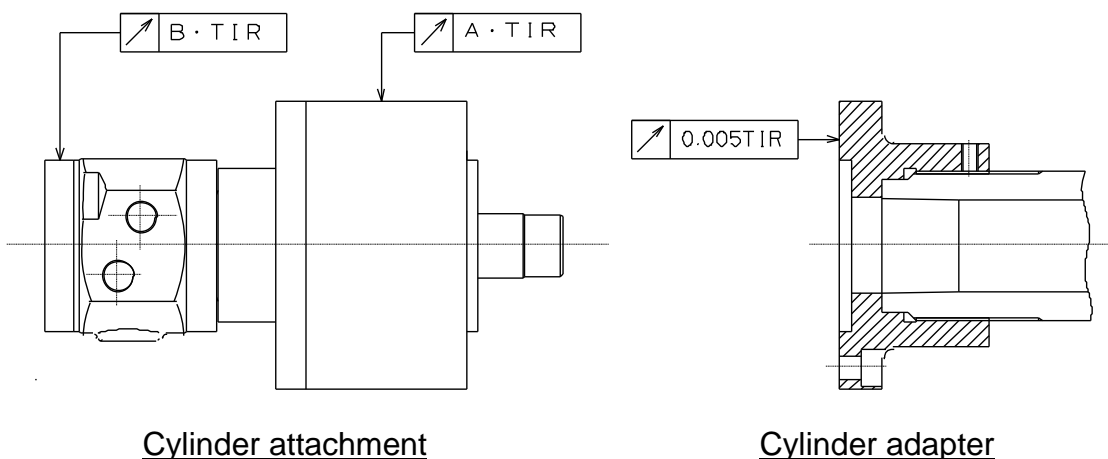

Fig. 15

Table 11 (Unit mm)

Type	A	B
Y0715R or equivalent	0.010	0.030
Y1020R or equivalent	0.010	0.030
Y1225R or equivalent	0.010	0.030
Y1530R or equivalent	0.010	0.030
Y2035R or equivalent	0.010	0.030

To obtain the above specified value of run-out, make the surface run-out of the cylinder adapter as small as possible. (0.005 mm TIR or less)

9-5. Tightening torque of the cylinder attaching bolt

Follow the figure below for the screw-in depth of the attaching bolt.

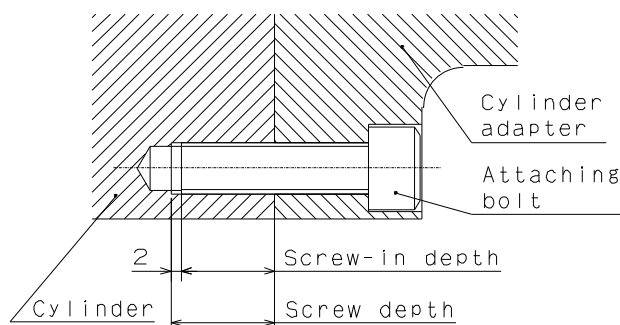

Fig. 16

Table 12

Type	Y0715R Y0715RE01C	Y1020R Y1020RE47	Y1225R Y1225RE47	Y1530R Y1530RE47	Y2035R Y2035RE47
Bolt size	M6	M10	M12	M12	M16
Screw depth	20	20	24	24	30

※ Keep the screw-in depth of the bolt to (screw depth -2) mm.



- Always tighten the bolts at the specified torque. If the torque is insufficient or excessive, the bolt will break, which is dangerous as the cylinder or work will fly out.
- Use bolts that have at least a strength classification of 12.9 (10.9 for M22 or more) and be sure they are long enough.

Table 13

Bolt size	Tightening torque
M6	10 N·m
M10	58 N·m
M12	85 N·m
M16	200 N·m

※ Since the material of the cylinder is aluminum, it is 80% of the tightening torque to the bolt size specified for the hydraulic chuck of our company.

10. About Hydraulic Circuit Design

- Consider the hydraulic circuit design so that the operation is easy and no mistakes in operation occur.
Attempt failsafe for the circuit so as not to cause any accidents even in the case of blackout. (Fig. 17)
- It is incorporated with a lock mechanism (lock valve) to maintain the specified gripping force even if the supplied pressure abnormally drops due to blackout or malfunction of the pressure resource while processing a work, however, it does not function unless the following warnings are observed.



- Additionally, the solenoid valve is to be in a circuit to retain the gripping port position when no electric current is carried.
The switching of the cylinder is to be 4 port 2 position with electromagnetic valve, and design the hydraulic circuit which grips the work in the state that the solenoid valve is degaussed.
If the circuit is designed in the opposite way, if there is a blackout, the work could be released and fly out.
- Provide a valve to switch over the inside and outside diameter gripping to prevent an operation mistake when changing the gripping.
Additionally, when a solenoid valve is used as this switching valve, use a 4 port 2 position valve with a position stopper that can retain the indicator circuit at the time of blackout.

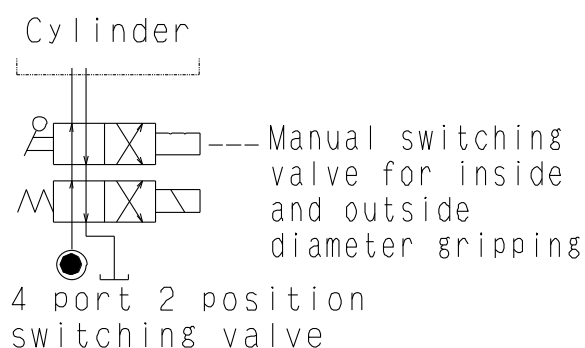

Fig. 17

- It is incorporated with a mechanism to stop damage when the hydraulic oil filled inside the cylinder has increased its pressure due to the volume change (relief valve). Pay attention to the points specified below for functional maintenance of lock valve and relief valve.

DANGER

- Assemble piping after completely removing the dust inside the pipe for functional maintenance of lock valve and relief valve.
- If the function of the lock valve lowers, this is dangerous as the work will fly out when the hydraulic pressure suddenly lowers due to blackout or malfunction of the hydraulic pump, etc.
- If the function of the relief valve lowers, the volume of the filled hydraulic oil changes causing an increase in pressure, which is dangerous resulting in malfunction.

WARNING

- To avoid serious injury from flying work, use the throttle valve to keep the surge pressure low. Operation failure and cylinder breakage may occur if a reducing valve used for the hydraulic pressure setting fails to respond to pressure adjustment and results in excessive surge pressure.

Remark) What is a “surge pressure”?

Pressure produced by a change in velocity of the moving stream that result from activating a hydraulic pump, operation of a solenoid valve.

NOTICE

- Select the operation equipment that matches the pipe diameter of the cylinder. The smaller the diameter is, the larger the pipe resistance becomes and the lower the acting speed is.

<Installation>

The hydraulic pressure supply ports are port A (cylinder pushing side) and port B (cylinder pulling side) in Fig.18.

Though both ports A and B have two ports each, connect the pipes to one port respectively and plug the reminders. For the size of each port, see Table 14.

Table 14

Type	Y0715R Y0715RE01C	Y1020R Y1020RE47	Y1225R Y1225RE47	Y1530R Y1530RE47	Y2035R Y2035RE47
A port	Rc3/8				
B port	Rc3/8				
Dr port	Rc1/4				



- Tighten plumbing and plug at the specified torque 20N·m. If the torque is insufficient or excessive, the cylinder will break and cause oil leakage which could result in a fire. It is dangerous because leakage cause the hydraulic pressure drop and work flying out.

11. Other information

11-1. About standards and orders

This product is based on the following standards or orders.

- Machinery directive:2006/42/EC Annex I
- EN ISO12100:2010
- EN1550:1997+A1:2008

11-2. Information about markings of product

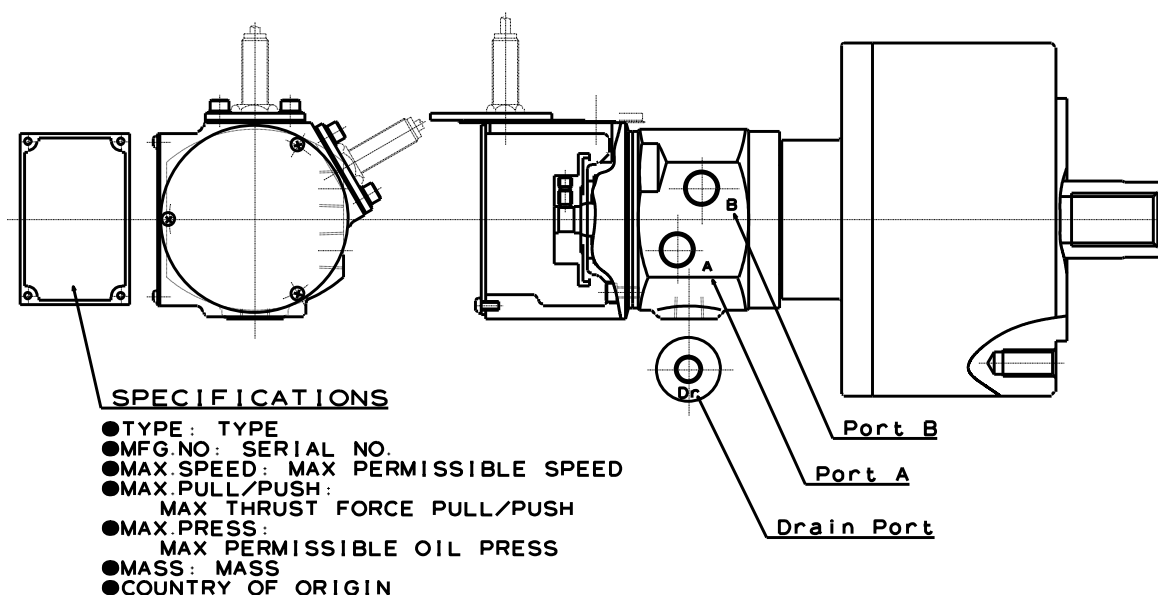

Fig.18

11-3.About disposal

Ultimate disposal of this product should be handled according to all national laws and regulations.

DECLARATION OF INCORPORATION
of partly completed machinery
Copy of original

We hereby declare that the following our product conform with the essential health and safety requirements of the EC Machinery Directive so that the product is to be incorporated into end-machinery. The product must not be put into service until end-machinery has been declared in conformity with the provisions of the EC Machinery Directive 2006/42/EC Annex II part 1.A.

We also declare that the specific technical documentation for this partly completed machinery was drawn up according to the EC Machinery Directive 2006/42/EC Annex VII part B.

Product : Cylinder

Model : Y-RE series
(Models Y0715RE, Y0720RE, Y0725RE, Y1020RE, Y1030RE
Y1225RE, Y1530RE, Y1550RE, Y2035RE, Y2050RE)

Serial number : See original declaration

Manufacturer : Kitagawa Corporation
77-1, Motomachi, Fuchu-shi,
Hiroshima 726-8610, Japan

Authorized compiler : Peter Soetebier / Prokurist
in the community Kitagawa Europe GmbH
Borsigstr.3 D-40880 Ratingen, GERMANY

The essential health and safety requirements in accordance with the EC Machinery Directive 2006/42/EC Annex I were applied and fulfilled:
1.1.2, 1.1.3, 1.1.5, 1.1.6, 1.2.6, 1.3.1, 1.3.2, 1.3.4, 1.5.3, 1.5.4, 1.5.8, 1.5.9, 1.5.13,
1.6.1, 1.7.1, 1.7.2, 1.7.3, 1.7.4, 1.7.4.1, 1.7.4.2

The following harmonized standards were applied:
EN ISO 12100:2010, EN 1550:1997+A1: 2008

Signature : See original declaration

Place / Date : See original declaration

Name / Title : Tomonari Hiromoto / Manager, Technical section 1
Technical department
Kitagawa Global hand Company

Being the responsible person appointed and employed the manufacturer.

Kitagawa Corporation Kitagawa Global hand Company

77-1, Motomachi, Fuchu-shi, Hiroshima, 726-8610, Japan

Tel. +81-847-40-0561

Fax. +81-847-45-8911

■ JAPAN DOMESTIC

Tokyo office	1-405-1, Kita-ku, Yosino-cho, Saitama-shi, Saitama, 331-9634, JAPAN Tel. +81-48-667-3469 Fax. +81-48-663-4678
Sendai office	4-15-13, Yamatomachi, Wakabayashi-ku, Sendai-shi, Miyagi, 984-0042, Japan Tel. +81-22-232-6732 Fax. +81-22-232-6739
Nagoya office	2-62, Kamitakabata, Nakagawa-ku, Nagoya-shi, Aichi, 454-0873, Japan Tel. +81-52-363-0371 Fax. +81-52-362-0690
Osaka office	3-2-9, Kitakagaya, Suminoe-ku, Osaka-shi, Osaka, 559-0011, Japan Tel. +81-6-6685-9065 Fax. +81-6-6684-2025
Hiroshima office	77-1, Motomachi, Fuchu-shi, Hiroshima, 726-8610, Japan Tel. +81-847-40-0541 Fax. +81-847-46-1721
Kyushu office	7-6-39, Itazuke, Hakata-ku, Fukuoka-shi, Fukuoka, 812-0888, Japan Tel. +81-92-501-2102 Fax. +81-92-501-2103
Overseas office	77-1, Motomachi, Fuchu-shi, Hiroshima, 726-8610, Japan Tel. +81-847-40-0526 Fax. +81-847-45-8911

■ OVERSEAS

America Contact	KITAGAWA-NORTHTECH INC. https://www.kitagawa.us 301 E. Commerce Dr, Schaumburg, IL. 60173 USA Tel. +1 847-310-8787 Fax. +1 847-310-9484
Europe Contact	KITAGAWA EUROPE LTD. https://www.kitagawa.global/en Unit 1 The Headlands, Downton, Salisbury, Wiltshire SP5 3JJ, United Kingdom Tel. +44 1725-514000 Fax. +44 1725-514001
	KITAGAWA EUROPE GmbH https://www.kitagawa.global/de Borsigstrasse 3, 40880, Ratingen Germany Tel. +49 2102-123-78-00 Fax. +49 2102-123-78-69
	KITAGAWA EUROPE GmbH Poland Office https://www.kitagawa.global/pl 44-240 Zory, ul. Niepodleglosci 3 Poland Tel. +48 607-39-8855
	KITAGAWA EUROPE GmbH Czech Office https://www.kitagawa.global/cz Purkynova 125, 612 00 Brno, Czech Republic Tel. +420 603-856-122 Fax. +420 549-273-246
	KITAGAWA EUROPE GmbH Romania Office https://www.kitagawa.global/ro Strada Heliului 15, Bucharest 1, 013991, Romania Tel. +40 727-770-329
	KITAGAWA EUROPE GmbH Hungary Office http://www.kitagawa.global/hu Dery T.u.5, H-9024 Győr, Hungary Tel. +36 30-510-3550
Asia Contact	KITAGAWA INDIA PVT LTD. https://www.kitagawa.global/in Plot No 42, 2nd Phase Jigani Industrial Area, Jigani, Bangalore – 560105, Karnataka, India Tel. +91-80-2976-5200 Fax. +91-80-2976-5205
	KITAGAWA (THAILAND) CO., LTD. Bangkok Branch 9th FL, Home Place Office Building, 283/43 Sukhumvit 55Rd. (Thonglor 13), Klongton-Nua, Wattana, Bangkok 10110, Thailand Tel. +66 2-712-7479 Fax. +66 2-712-7481
	Kitagawa Corporation (Shanghai) https://www.kitagawa.com.cn/ Room 308 3F Building B. Far East International Plaza, No. 317 Xian Xia Road, Chang Ning, Shanghai, 200051, China Tel. +86 21-6295-5772 Fax. +86 21-6295-5792
	Kitagawa Corporation (Shanghai) Guangzhou Office B07, 25/F, West Tower, Yangcheng International Trading Centre, No. 122 East Tiyu Road, Tianhe District, Guangzhou, China Tel. +86 20-2885-5276
	DEAMARK LIMITED http://www.deamark.com.tw No. 6, Lane 5, Lin Sen North Road, Taipei, Taiwan Tel. +886 2-2393-1221 Fax. +886 2-2395-1231
	KITAGAWA KOREA AGENT CO., LTD. http://www.kitagawa.co.kr 803 Ho, B-Dong, Woolim Lion's Valley, 371-28 Gasan-Dong, Gumcheon-Gu, Seoul, Korea Tel. +82 2-2026-2222 Fax. +82 2-2026-2113
Oceania Contact	DIMAC TOOLING PTY. LTD. http://www.dimac.com.au 69-71 Williams Rd, Dandenong South, Victoria, 3175 Australia Tel. +61 3-9561-6155 Fax. +61 3-9561-6705

The products herein are controlled under Japanese Foreign Exchange and Foreign Trade Control Act.
 In the event of importing and/or exporting the products, you are obliged to consult KITAGAWA as well as your government for the related regulation prior to any transaction.