

INSTRUCTION MANUAL MODEL NPG3 3-jaw Sealed Gripper



DANGER

- This Instruction Manual has been prepared for intended use for production engineers and maintenance persons who operate this product. When the beginners use this product, be sure to receive the guidance from skilled persons, sales agents, or us in advance.
- Before installing, using, or maintaining this product, read carefully the safety precautions given in this manual so as to understand them completely. If you do not heed given instructions or safety precautions, serious human accidents, death, or physical damage may occur.
- Store this manual with care in the specified place at hand, and reread it as necessary for correct use of the product.
- Please contact the sales agent if you have any uncertainty or doubt about this manual.

Preface

This manual provides detailed information on the 3-jaw sealed gripper (model NPG3) so that you can understand its performance and functions and use it safely and correctly.

Before using this gripper, read this manual carefully to understand how to use the gripper correctly. Always follow the instructions and warnings given in **“Important Safety Precautions”** and **“Precautions for Use”**. Failure to follow these precautions could result in serious human accidents.

Terms and Symbols Used for Safety Messages

In this manual, handling precautions that are considered especially important are classified and displayed as shown below according to the degree of risk (seriousness of harm) that could result. Please completely understand the meaning of these terms and follow the instructions for safe operation.



Safety Alert Symbol

This triangle is a safety alert symbol used to alert you to potential safety hazards. To avoid death or injuries that could occur, follow the safety messages given with this safety alert symbol.



Failure to follow the safety precautions below will result in death or serious injuries.



Failure to follow the safety precautions below could result in death or serious injuries.



Failure to follow the safety precautions below may result in minor or moderate injuries.



Indicates instructions which, if you do not heed given instructions, could result in damage to the product or shortened service life, or damage to peripheral equipment.

Disclaimer and How to Use Instruction Manual

This product is suitable for gripping a conveyed workpiece by being installed on the robot or loader. The product is equipped with the jaws to grip the conveyed workpiece and they are operated by air pressure. For any other applications, please contact us.

Kitagawa Corporation shall not be held liable for human accidents, death, damage, or loss that occurred due to a failure to follow the safety precautions given in this manual.

This manual does not predict all potential hazards in operation, inspection, and maintenance under all environmental conditions. There will be an infinite number of matters that cannot or must not be done, and it is impossible for the manual to cover all of them.

Therefore, the matters, unless otherwise mentioned clearly as “can be done” or “may be done” in this manual, should be considered as “cannot be done” or “must not be done”.

Please contact us or our agents if you have an uncertainty about safety when you try to perform operation, inspection, or maintenance not mentioned in this manual.

Warranty and Disclaimer

The product is warranted for one year after the date of delivery.

All parts used shall be those delivered by Kitagawa Corporation. Kitagawa Corporation shall not be held liable for human accidents, death, damage, or loss that occurred due to the use of parts which are not genuine parts manufactured by Kitagawa. Also, the use of parts other than Kitagawa’s genuine parts will void the warranty.

Contents

1. Structural Drawing and Parts List	4
1-1. Model indication	
1-2. Structural drawing	
1-3. Seal list	
1-4. Parts list	
2. Important Safety Precautions	6
3. Specifications	10
3-1. Specification table	
3-2. Gripping force	
4. Use	13
5. Design of Jaws	14
5-1. Designing jaws to be installed on the gripper	
6. Installation	15
6-1. Installing the gripper	
6-2. Installing the jaws	
6-3. Connecting the air piping	
6-4. Installing the switches	
7. Maintenance and Checking	21
7-1. Periodic checking	
7-2. Maintenance interval	
7-3. Grease	
7-4. Air circuit maintenance	
7-5. Disassembly and assembly procedure	
8. Troubleshooting	26
8-1. Problems and countermeasures	
8-2. Contact address in case of trouble	
9. Others	27
9-1. Standards and directives to which the gripper conforms	
9-2. Disposal of gripper	

1. Structural Drawing and Parts List

1-1. Model indication

The model indication is as follows:

NPG3 10

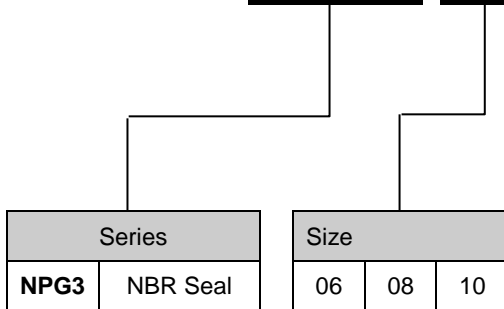

1-2. Structural drawing

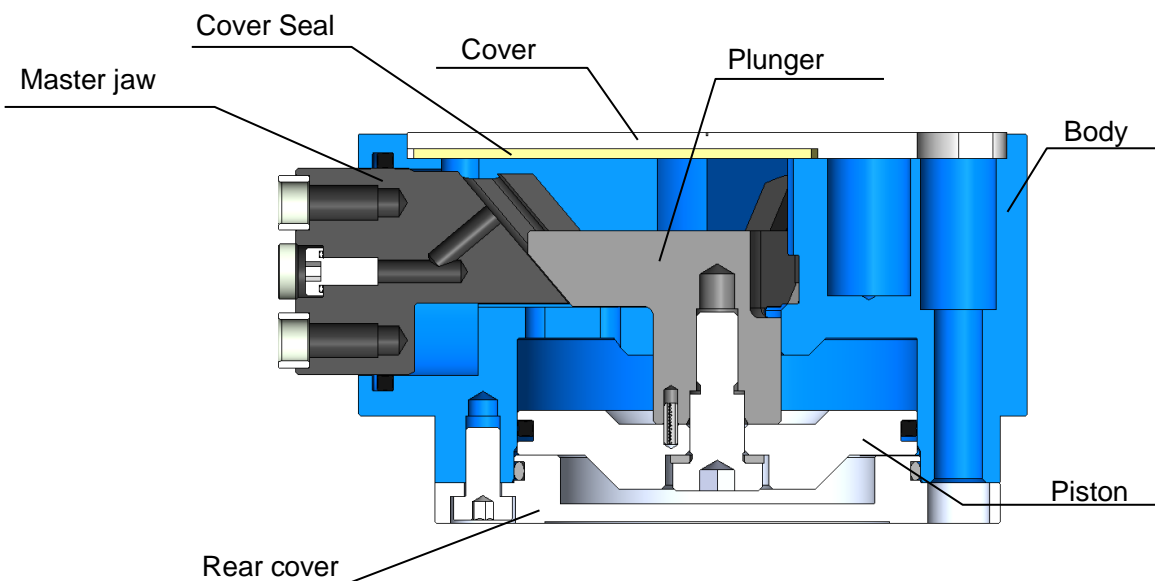

1-3. Seal list

型式	No.				
	206	207	208	209	210
NPG306	O-ring SS6	O-ring S36	X-ring X118	X-ring X125	Seal washer 4S1
NPG308	O-ring SS4.5	O-ring S56	X-ring X123	X-ring X137	Seal washer 8S1
NPG310	O-ring S5	O-ring S75	X-ring X126	X-ring X232	Seal washer 10S1

1-4. Parts List

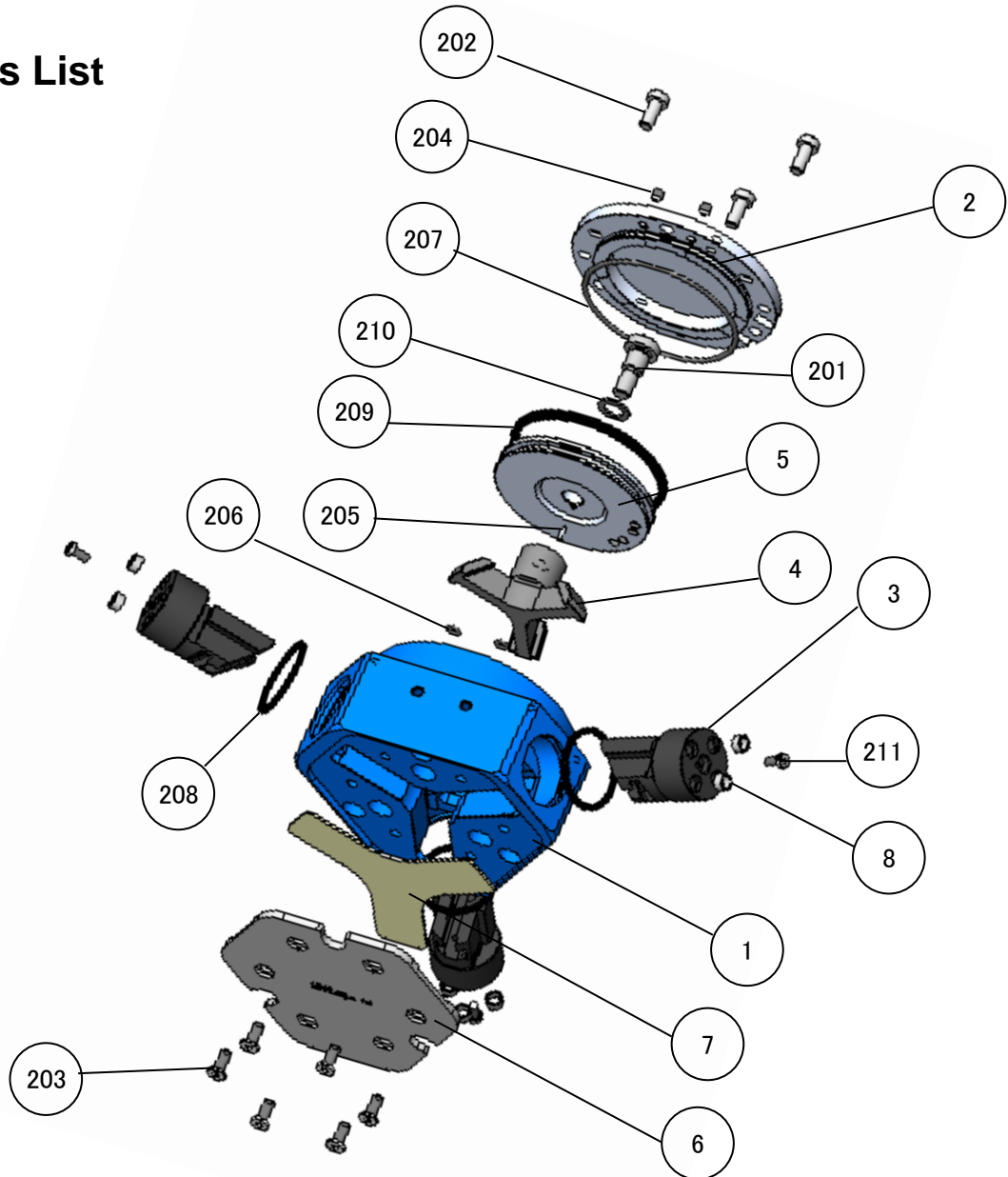

No.	部品名称	個数	No.	部品名称	個数
1	Body	1	203	Cover fixing bolt(NPG306,NPG310)	6
2	Rear cover	1		Cover fixing bolt(NPG308)	12
3	Master jaw	3	204	Set screw	2
4	Plunger	1	205	Spring pin	1
5	Piston	1	206	O-ring A	2
6	Cover	1	207	O-ring B	1
7	Cover seal	1	208	Jaw packing	3
8	Positioning bushing	12	209	Piston packing	1
201	Piston fixing bolt	1	210	Seal washer	1
202	Rear cover fixing bolt	3	211	Seal cap bolt	3

※ NPG306 does not have a 205 spring pin.

2. Important Safety Precautions

Important safety precautions that particularly you should know or follow are summarized below. Please read them before starting to use the product.



DANGER

Failure to follow the safety precautions below will result in death or serious injuries.



Be sure to turn off the main power supply when installing, checking, oiling, or replacing the gripper.

Also, shut down the air pressure in the work area.

- During work, the robot or gripper could move abruptly and collide with your body.
- After shutting down the air pressure, release the air pressure remaining inside the gripper.

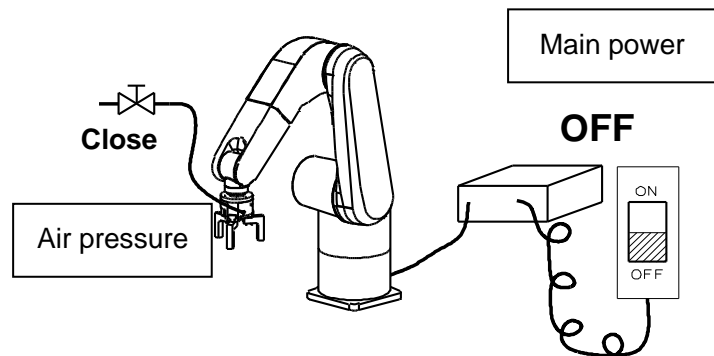

When installing, checking, oiling, or replacing the gripper, post a sign or notice, or provide a fence, and so on to notify people around the machine that work is in progress.

- Notify people around the machine that work is in progress and take measures to keep people other than the operator out of the work area.
Machine motion not predicted by a third party could cause serious danger.



Take safety measures so that the operator is not injured even if the conveyed workpiece flies out due to the reduced air pressure.

- Observe the legal safety standards defined by each country, such as installation of safeguards or fall prevention covers.

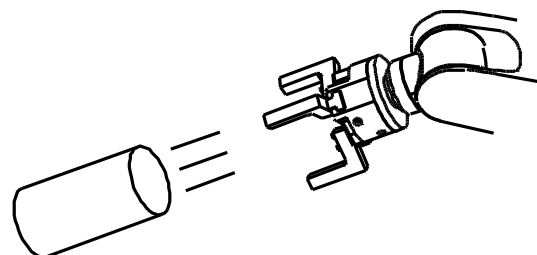



DANGER

Failure to follow the safety precautions below will result in death or serious injuries.



Do not modify the gripper.

- Not only the gripper is damaged but also the gripper and fixed workpiece may fly out.

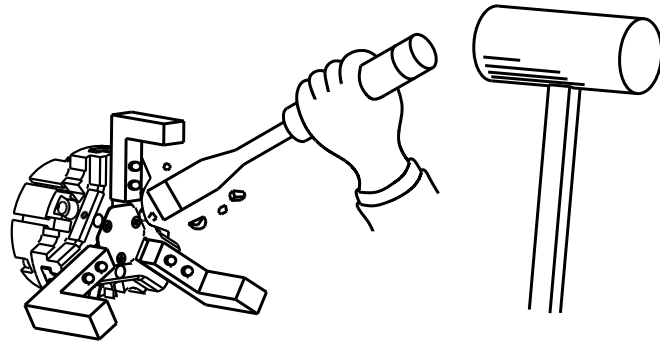

If using the gripper as a workpiece fixture when the workpiece is drilled, deburred, welded, or modified additionally, confirm the specifications.

- If the gripper is used out of the specifications, not only the gripper is damaged but also the fixed workpiece may fly out.



Be sure to tighten the bolts with the specified torque.

- Lack of bolt quantity or tightening torque, or excessive torque could damage the bolt, causing the gripper or conveyed work piece to fly out.
- When tightening the bolts, fix the gripper so that it will not rotate. Failure to do so may result in injury by slipping your hands when tightening the bolts.

Gripper body fixing bolt

Boltsize	Tightening torque	
M5	5.5	N·m
M6	10.8	N·m
M8	26.5	N·m

Piston fixing bolt

Boltsize	Tightening torque	
M4	3.2	N·m
M6	10.8	N·m
M8	26.5	N·m

Cover fixing bolt

Boltsize	Tightening torque	
M4	2	N·m
M5	3.5	N·m

Rear body fixing bolt

Boltsize	Tightening torque	
M4	2.4	N·m
M5	4.8	N·m
M6	8.6	N·m

Seal cap bolt

Boltsize	Tightening torque	
M3	1.4	N·m
M4	3.2	N·m



DANGER

Failure to follow the safety precautions below will result in death or serious injuries.



Use the gripper in accordance with the legal safety standards.

- Use the gripper in accordance with the legal safety standards defined by each country, such as installation of safeguards or safety covers.

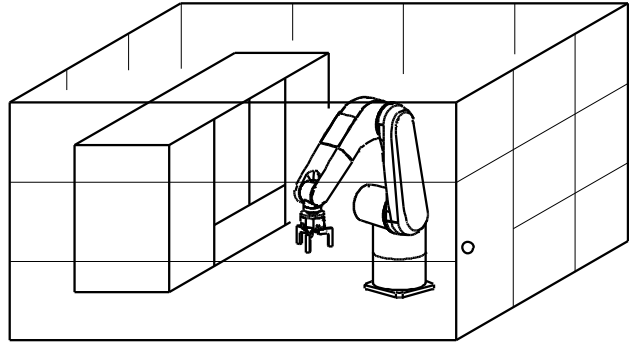



WARNING

Failure to follow the safety precautions below will result in death or serious injuries.



Do not operate the machine after drinking alcohol or taking medicine.

- Impaired judgment or operation mistake may cause serious hazards.

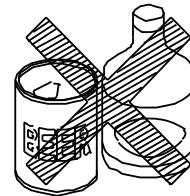

Alcohol

Medicine



Do not wear clothing or accessories such as a necktie, necklace, etc. which are easy to be caught in.

- You may be caught in the gripper.

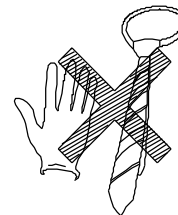

Use the gripper within the range of specification values.

- When selecting a gripper, select the model by referring to "Model selection" in page 14.
- Have the gripper grip the conveyed workpiece at the position of its center of gravity.
- If not, not only the gripper is damaged but also the conveyed workpiece may fly out.

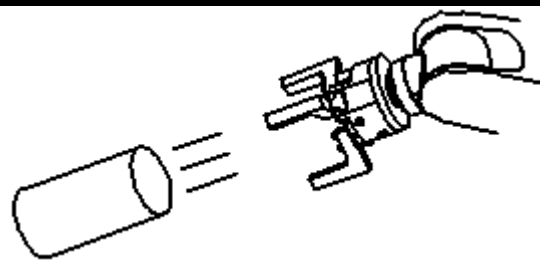

3. Specifications

3-1. Specification table

Model	NPG		
	306	308	310
Fluid used	Air pressure		
Operating air pressure (MPa)	0.2~0.8		
Ambient temperature range (°C)	5~60		
Jaw stroke in diameter (mm)	12	16	20
Cylinder internal volume (reciprocation) (cm ³)	33.3	68.4	139.7
Repeatability (mm)	±0.01		
Body Mass (kg)	0.5	1.3	2.1
Ambient humidity range (%)	30~95		
Storage temperature range (°C)	5~60		
Noise level (dB)	79		

*Noise level is measured at a distance of 1m at four locations on the front, rear, left, and right of the gripper.

3-2. Gripping force

① Standard for selecting a model

Perform the following calculation and select the model that provides a gripping force exceeding the calculation result, though a gripping force varies depending on the shapes of jaws created by the customer and conveyed workpiece or the friction coefficient.

$$F = m(g+a) / \mu$$

(Example) When mass of conveyed workpiece
and robot acceleration = 10m/s²:
 $F = 8(9.8+10) / 0.1 = 1584 \text{ (N)}$

F = Gripping force (N)
m = Mass of conveyed workpiece (kg)
g = Gravitational acceleration (m/s²)
a = Acceleration of robot/loader (m/s²)
 μ = Friction coefficient of gripping part

② Gripping force

● External gripping

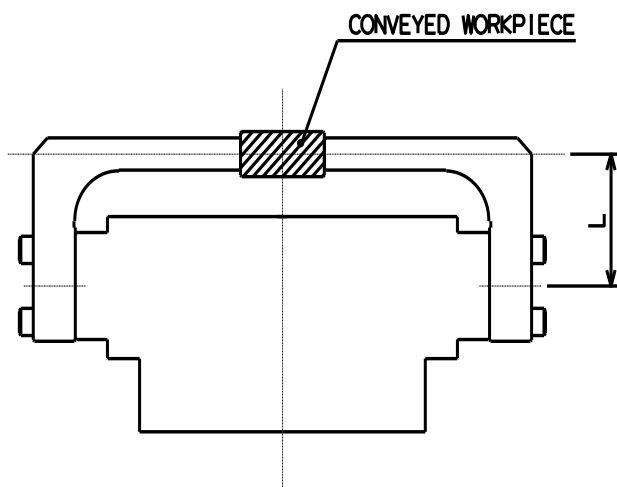

● Internal gripping

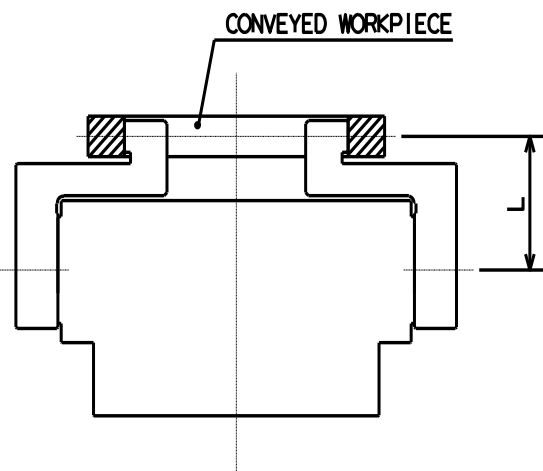

L: Distance up to a grip point(mm)

● Expression of gripping force

A gripping force F shown in graph is actually measured gripping force per jaw F1 x the number of jaws.

$$(F = F1 \times 3)$$

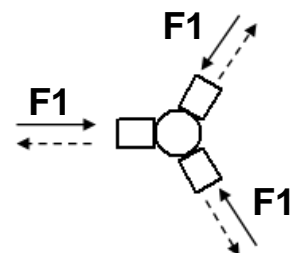

----- Internal gripping
—— External gripping

■ NPG306

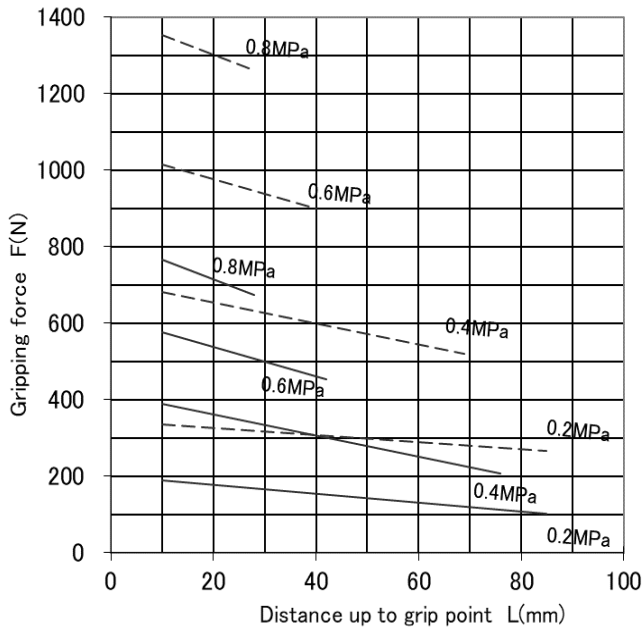

■ NPG308

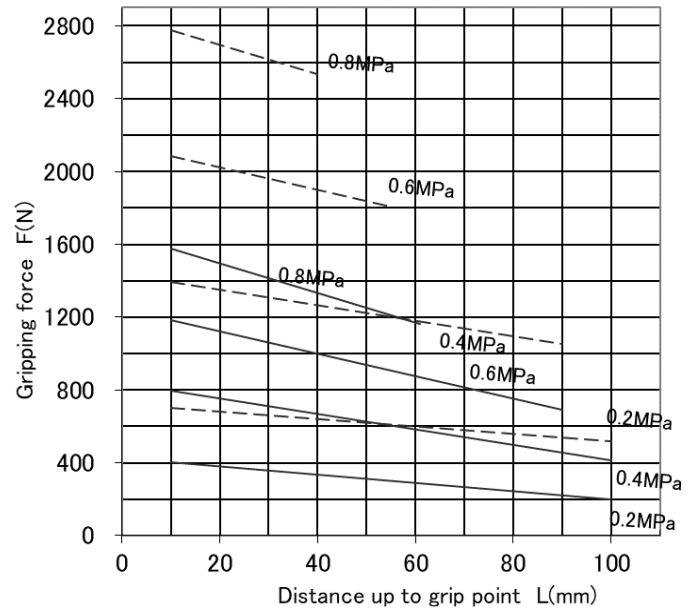

■ NPG310

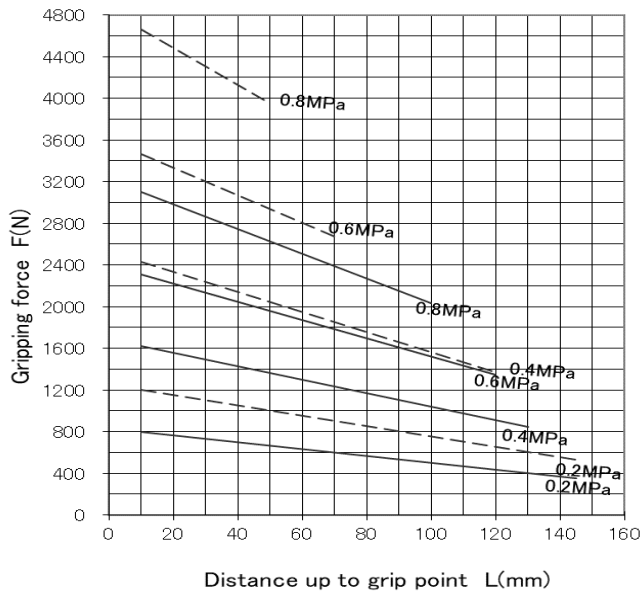

NOTICE

- Determine the distance up to a grip point L as short as possible when designing the jaws. Also, the distance up to a grip point L should be used within a range shown in graph. If it is used out of the range, not only the specified gripping force may not be obtained but also the wear of sliding parts may be increased.

4. Use

This product supplies pneumatic pressure to the unit to move the jaws in the open or close direction for gripping the conveyed workpiece and transfers the conveyed workpiece up to any location. After transfer, the jaws are moved in the close or open direction for removing the conveyed workpiece.

DANGER

- Do not modify the gripper. Using the modified product could cause unexpected accidents. Kitagawa shall not be held liable for human accidents, death, damage, or loss that occurred due to the modification.

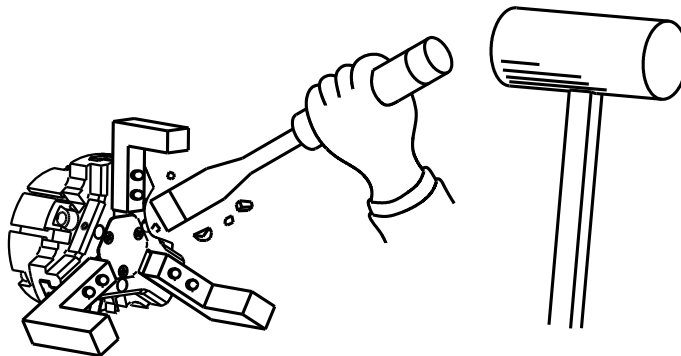

- If using the gripper as a workpiece fixture when the workpiece is drilled, deburred, welded, or modified additionally, confirm the specifications. If the gripper is used out of the specifications, not only the gripper is damaged but also the fixed workpiece may fly out.

WARNING

- Wear appropriate clothing suitable for the work and wear gloves, safety glasses, safety shoes, and helmet.
 - Wearing inappropriate clothing causes the clothing to be stuck, resulting in danger.
 - Appropriate clothing will be preventive measures to prevent hazards due to the carelessness or unexpected accidents during work.

NOTICE

- Do not use the product in the environment of corrosive chemicals, corrosive gas, dust, and vibration, avoiding high temperature or direct sunlight.
- When storing the product, apply antirust treatment and then store it in a place free from water leakage, dew condensation, or freeze.
- Increase the maintenance frequency when gripper is used in an environment directly exposed to water or oil because the seal life will be reduced.

5. Design of Jaws

5-1. Designing jaws to be installed on the gripper

When designing jaws to be installed on the gripper, form the installation face to the master jaw as shown below.

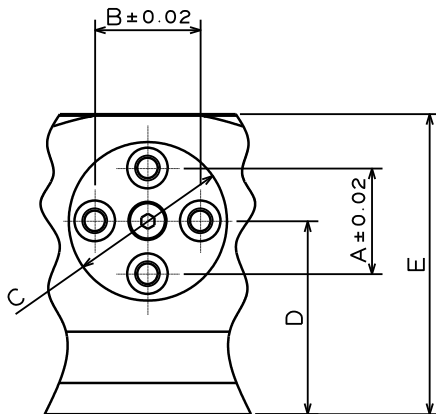
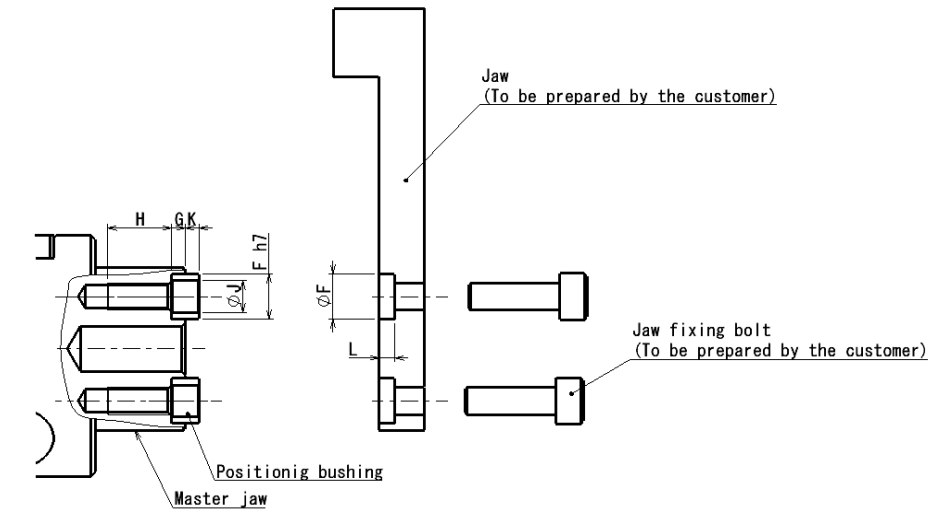

Model	A	B	C	D	E	F	G	H
NPG306	15.2	15.2	φ22.5	32.5	49	φ6	2	6
NPG308	20	20	φ30	36.5	56.5	φ8	2	10
NPG310	22.5	22.5	φ33.5	45.6	67.3	φ8	2	10

Model	J	K	L	Mounting bolt size
NPG306	φ4.5	2	3	M4
NPG308	φ6	2.5	3.5	M5
NPG310	φ6	2.5	3.5	M5

6. Installation

6-1. Installing the gripper

① Front face installation

Install the gripper body using three fixing bolt holes and two positioning pin holes. The gripper fixing adapter, gripper fixing bolts, and positioning pins are to be prepared by the customer.

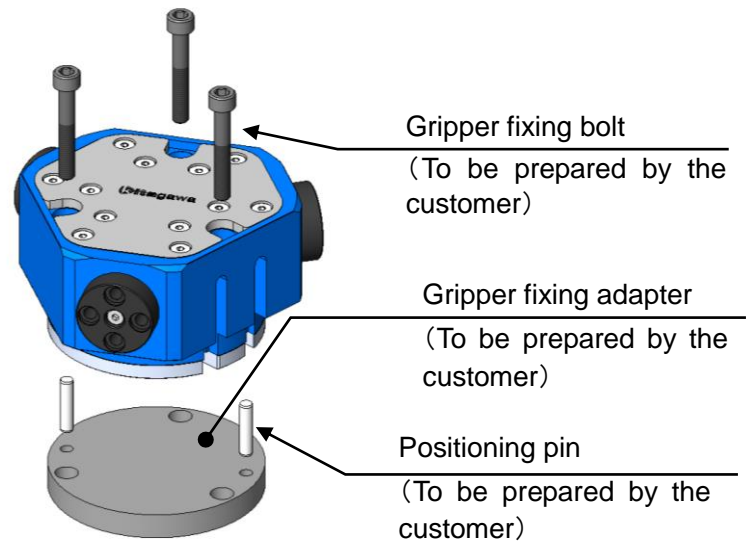

【Note】

Interference may occur between the adapter and reed switch during installation. Take measures such as making holes in the adapter to prevent interference.

Model		NPG	306	308	310
Gripper fixing bolt size			M5	M6	M6
Positioning pin hole	Diameter ($0^{+0.025}$) (mm)		$\phi 4$	$\phi 5$	$\phi 5$
	Depth (mm)		8(12.8)	12(17.9)	12(18.6)

* Dimensions in () indicate the depth from the mounting surface.

② Rear face installation

Install the gripper body using three fixing bolt holes and two positioning pin holes. The gripper fixing adapter, gripper fixing bolts, and positioning pins are to be prepared by the customer.

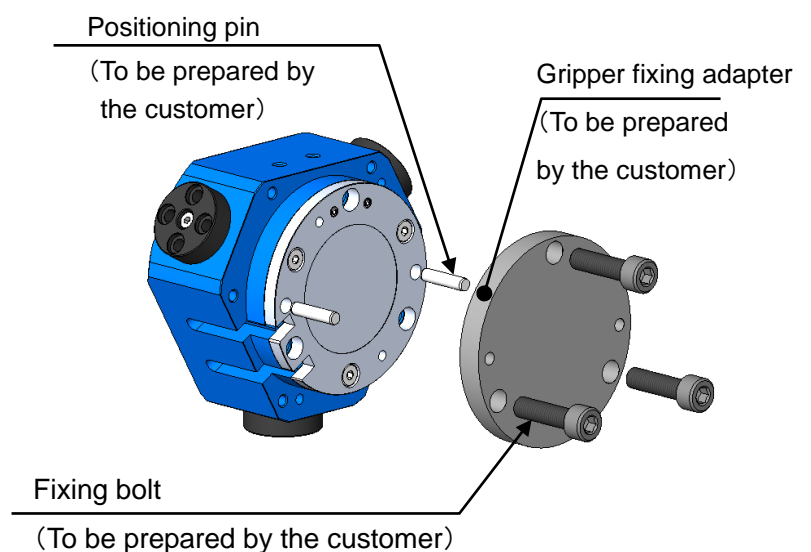

【Note】

Interference may occur between the adapter and reed switch during installation. Take measures such as making holes in the adapter to prevent interference.

Model		NPG	306	308	310
Gripper fixing bolt	Size		M6	M8	M8
	Thread depth (mm)		14(18.8)	14(19.9)	14(20.6)
Positioning pin hole	Diameter ($0^{+0.025}$) (mm)		$\phi 4$	$\phi 5$	$\phi 5$
	Depth (mm)		8(12.8)	12(17.9)	12(18.6)

* Dimensions in () indicate the depth from the mounting surface.

③ Center surface installation

Install the gripper body using the six fixing bolt holes and two positioning pin holes. The gripper fixing adapter, gripper fixing bolts, and positioning pins are to be prepared by the customer.

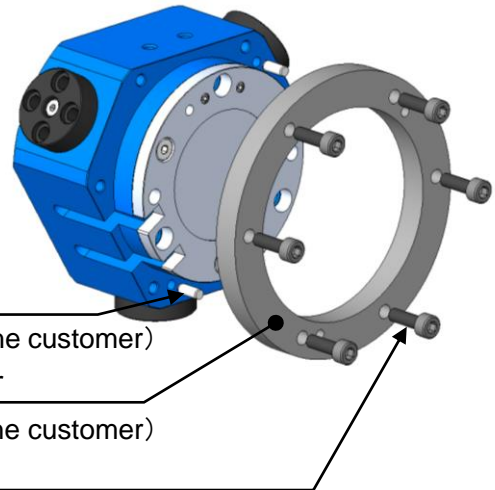

- Positioning pin
(To be prepared by the customer)
- Gripper fixing adapter
(To be prepared by the customer)
- Fixing bolt
(To be prepared by the customer)

【Note】

Interference may occur between the adapter and reed switch during installation. Take measures such as making holes in the adapter to prevent interference.

Model		NPG	306	308	310
Gripper fixing bolt			-	M5	M5
Positioning pin hole	Diameter ($0^{+0.025}$) (mm)		-	$\phi 4$	$\phi 5$
	Depth (mm)		-	5	7

* Dimensions in () indicate the depth from the mounting surface.



- Be sure to tighten the bolts with the specified torque. Lack of tightening torque or excessive torque could break the bolts, causing the gripper or conveyed workpiece to fly out.

NOTICE

- NPG306 does not support intermediate surface mounting.

6-2. Installing the jaws

Install the jaws using four mounting bolt holes, spigot joint and positioning bushing holes. The jaws, jaw fixing bolts, and positioning bushings are to be prepared by the customer.

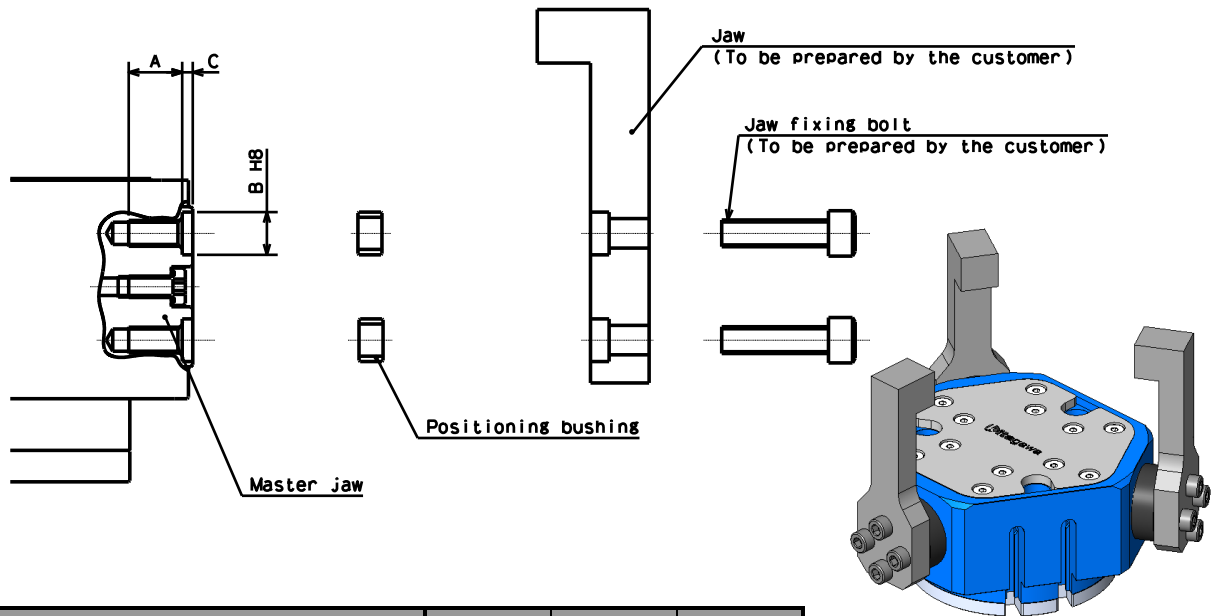

Model	NPG		306	308	310
Mounting bolt	Size		M4	M5	M5
	Thread depth	A (mm)	6	10	10
Positioning pin hole	Diameter (H8)	B (mm)	φ6	φ8	φ8
	Depth	C (mm)	2	2	2

DANGER

- Be sure to tighten the bolts with the specified torque. Be sure to tighten the bolts with the specified torque. Lack of tightening torque or excessive torque could break the bolts, causing the jaws or conveyed workpiece to fly out.
- Before installing the jaws, disconnect the air piping.

6-3. Connecting the air piping

The air pressure supply ports to open and close the gripper jaws are provided on the side face and rear face of the body.

When using the supply port on the side face of the body, connect the air piping directly.

When using the supply port on the rear face of the body, remove the setscrew, which is attached at the delivery to prevent air leakage, and supply air from the adapter to fix the gripper.

The screws to close the open/close ports on the side face of the body are to be prepared by the customer.

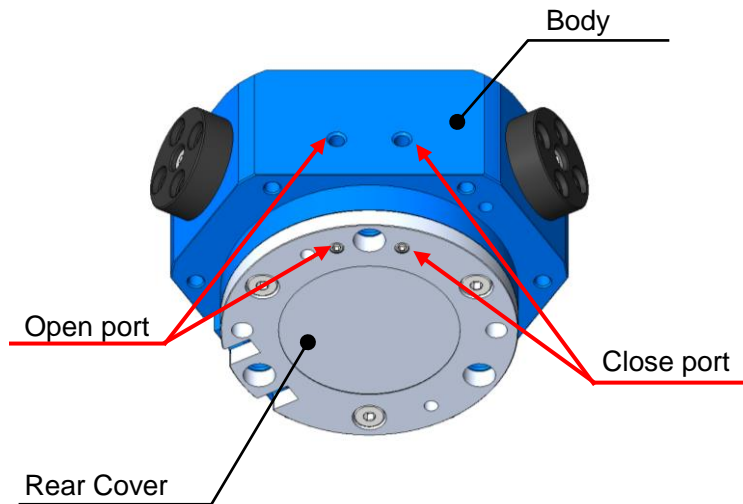

Model	NPG	306	308	310
Port size on body side face		M5	M5	M5
Port size on body rear face		M4	M4	M5

NOTICE

- The setscrews in the air pressure supply ports on the body rear face are mounted with adhesive applied to them to prevent air leakage, so it is very difficult to remove them. Therefore, when removing the setscrews, be careful not to damage them.
- After removing the setscrews, take away adhesive fixed to the body screw hole clearly. Be careful not to drip the adhesive into the cylinder.

 **WARNING**

- Be sure to shut off the air pressure before connecting the air piping.
- Use compressed air as the fluid.
- Do not use compressed air that contains chemicals, synthetic oils containing organic solvents, salt, or corrosive gases, as it may cause damage or malfunction.

 **CAUTION**

- Use clean air that has passed through an air filter (filtration of 5 μm or less).
- Keep the fluid temperature and ambient temperature within the range of 5 to 60°C.
- Can be used without lubrication, but if lubricated, please use Class 1 turbine oil (no additives) ISO VG32.
- Select an after cooler, air dryer, mist separator, etc., according to ISO 8573-1 Class 4, and take measures against drainage.
- Adjust with a speed controller, etc. so that the opening/closing speed does not become faster than necessary.

6-4. Installing the switches

Use reed switches of the following models.

NPG306

	CKD Noncontact 2-Wire System
Model	F2S
Lead Wire Output Shape	L-Shape Short

* Using reed switches not shown below may lead to unstable response.

NPG308, NPG310

	CKD			SMC	
	Noncontact	2-wire system		Noncontact	2-wire system
Model	F2H	F2V	F2S	D-M9B	D-M9BV
Lead Wire Output Shape	Straight	L-shaped	L-shaped short	Straight	L-shaped

* Using reed switches not shown below may lead to unstable response.

① Installing the reed switch

Mount reed switches using the grooves on the side of the rear body. There are two reed switch mounting grooves, and up to two reed switches can be mounted.

When using reed switches, design adaptors so that the adaptors will not interfere with the reed switches.

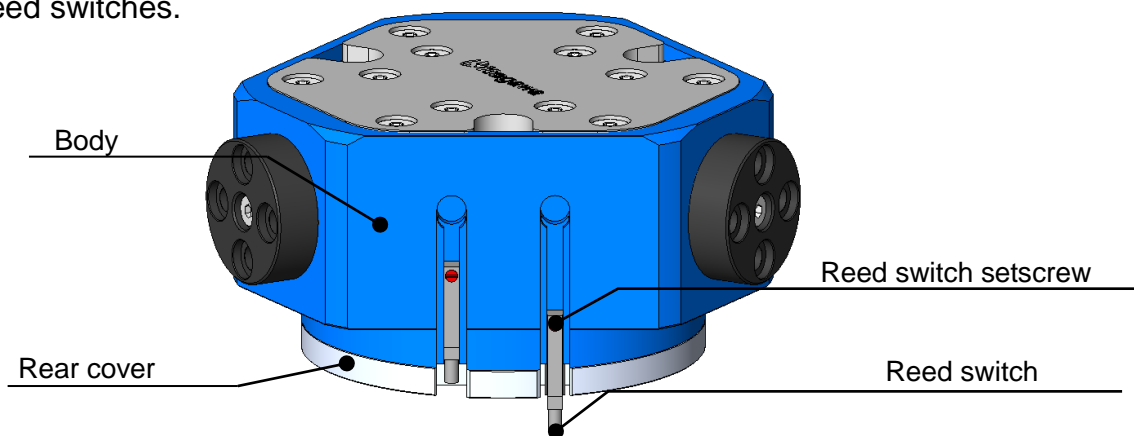

● Installation procedure for the close end side

- ① Move the master jaws to the close end positions, respectively.
- ② Mount a reed switch using the groove on the body.
- ③ Move up and down the reed switch slowly.
- ④ Tighten and fix the setscrew on the reed switch at the position detected by the reed switch.
- ⑤ Repeat the opening/closing operation of the master jaws to confirm that the reed switch can detect.

*In the case of workpiece external gripping, make the above-mentioned adjustment with the workpiece gripped.

● Installation procedure for the open end side

- ① Move the master jaws to the open end positions, respectively.
- ② Mount a reed switch using the groove on the body.
- ③ Move up and down the reed switch slowly.
- ④ Tighten and fix the setscrew provided on the reed switch at the position detected by the reed switch.
- ⑤ Repeat the opening/closing operation of the master jaws to confirm that the reed switch can detect.

7. Maintenance and Inspection

7-1. Periodic inspection

- Before work or when resupplying grease, move the jaws to full stroke position to check that the stroke mentioned in the specification table is obtained.
- At the end of work, be sure to clean the gripper main body using an air gun or the like.
- At least every three months, check that the bolts are not loose.
- The cover mounting bolt (No.202) may rust due to deterioration over time or repeated tightening and removal. If rust occurs, replace the bolt immediately.

7-2. Maintenance interval

- The maintenance interval is 1 million cycles, and disassemble the gripper, clean, replace the seals, lubricate, and reassemble the gripper.
- If the gripper is used in a situation where it is directly exposed to water or oil, check for air leaks every 200,000 cycles. If air leaks are found, disassemble the gripper, clean, replace the seals, lubricate, and reassemble the gripper.

7-3. Grease

① Grease used

- Be sure to use the specified grease listed below. If unspecified grease is used, adequate effect may not be obtained.

Brand	Manufacturer
MOLYCOTE BR2 Plus Grease	DuPont de Nemours, Inc. : Whole world

② Grease gun and nozzle

- Supply the grease gun and nozzle using the nozzles recommended below.

Equipment name	Model	Manufacturer
Grease gun	KH-120	Yamada Corporation
Nozzle	HSP-3	Yamada Corporation

③ Grease resupplying method

- Remove jaws from master jaw (No.3)
- Confirm that the residual pressure is released or remove the seal cap bolt (No.211) in the closed state.

⚠ DANGER

- Grease will dangerously spray off by air pressure if the seal cap bolt (No.211) is removed in the open state without releasing the residual pressure

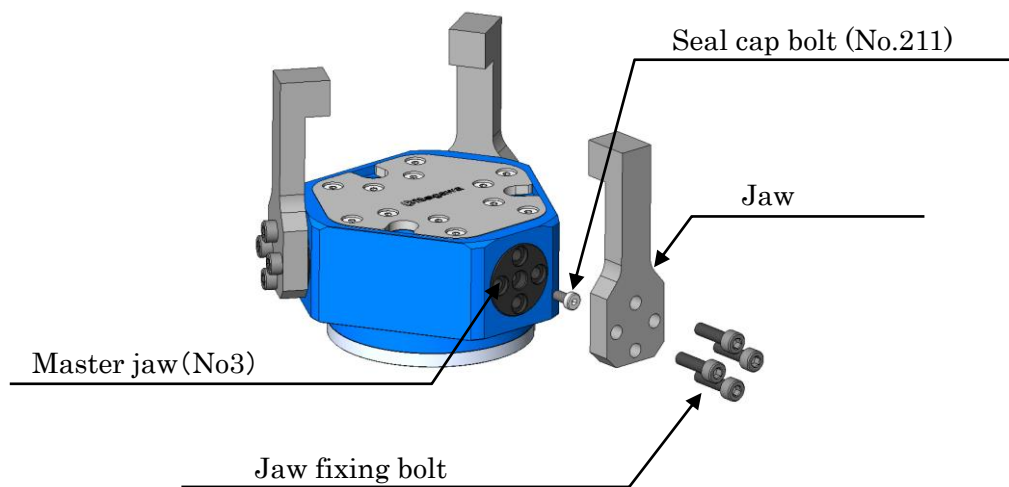

- Resupply the grease with the tip of the nozzle pressed against the grease supply port at the center of the three master jaws (No.3). Please resupply 0.5 gram at each place.
* Please contact the grease gun manufacturer for how to use the grease gun.

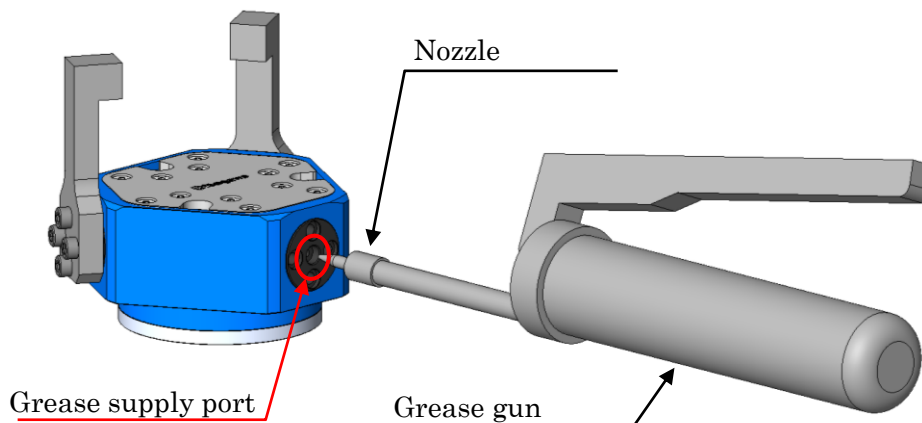

- After attaching the seal cap bolt (No. 211) to the grease supply port at the specified torque, attach the jaws and bolt.

Note 1: Refer to page 7 for the tightening torque of the seal cap bolt (No.211).

④ Safety information on grease and antitrust oil

Applicable range

- Specified grease
- Antitrust agent applied to the product at the delivery

First-aid treatment

- **Aspiration:** In case of much aspiration, go to a place where there is fresh air, and cover your body with a blanket to keep your body warm. Consult a doctor if necessary.
- **Sticking to your skin:** Wipe off the oil, and wash your skin with water and soap. If you feel itchy or you get inflamed, consult a doctor immediately.
- **Entering your eye:** Wash your eye with fresh water for at least 15 minutes, and then consult a doctor.
- **Accidental drinking:** Consult a doctor immediately without vomiting forcibly.
- For the grease other than the specified one and antitrust oil prepared by the customer, refer to the safety information prepared for respective oils.

7—4. Air circuit maintenance

- Periodically drain the air filter, etc.
- If foreign matter such as carbonized compressor oil enters the circuit, the solenoid valve and robot hand will malfunction, so be careful when performing maintenance and inspection of the compressor.

7-5. Disassembly

Disassembly procedure

By referring to the parts list on page 5 and 6, disassemble the product through the procedure below:

- ① Stop the air pressure supplied to the gripper and disconnect the air piping.
- ② Remove the gripper from the robot or the loader.
- ③ Remove the cover fixing bolts (No. 203), cover (No.6) and the cover seal (No. 7).
- ④ Remove the rear cover fixing bolt (No.202) and the rear cover (No.2).
- ⑤ Remove the plunger (No.4), piston(No.5), and master jaw (No.3) by pushing the plunger (No.4) from the cover (No.6) side.
- ⑥ Loosen the piston fixing bolts (No. 201) and disassemble the plunger (No. 4) and piston (No.5).

Assembly procedure

By referring to the parts list on page 5 and 6, assemble the product through the procedure below:

- ① Assemble the plunger (No.4) and piston (No. 5) and attach the piston fixing bolt (No.201).
Note 1: Insert the spring pin (No.205) into the piston (No.5) and align the phase with the pin hole of the plunger (No.4).
Note 2: Insert the seal washer (No.210) into the piston fixing bolt (No.201) and attach it.
- ② Insert the master jaw (No.3) into the body (No.1).
- ③ With the master jaw (No.3) and plunger (No.4) fitted together, fix the piston fixing bolt (No.201) with the specified torque.
Note 1: Refer to page 7 for the tightening torque of the piston fixing bolt (No.201).
Note 2: Align the magnet position of the piston with the sensor groove provided on the body.
- ④ Fix the rear cover (No.2) using the rear cover fixing bolts (No.202).
- ⑤ Fix the cover (No.4) using the cover fixing bolts (No.203)
- ⑥ Install the gripper to the robot or the loader.
- ⑦ Connect the air pressure piping.

To reassemble the gripper, apply the specified grease to the sliding parts and the oil treatment to the seal sliding parts. Make sure that the seal does not stick out or fall off, and perform the procedure in reverse order for disassembly while checking that the seals do not protrude or fall off.

Oil treatment used

Be sure to use the specified oil treatment shown below.

Brand	Manufacturer
S-10 Oil treatment	Napolex: Japan



- Be sure to tighten the bolts with the specified torque. Lack or tightening torque or excessive torque could break the bolts, causing the conveyed workpiece to fly out.

8. Troubleshooting

8-1. Problems and countermeasures

Check the following, and take corrective actions.

Symptom	Cause	Corrective actions
Gripper does not operate	Gripper internal part is broken.	Replace the gripper with a new one.
	The sliding surface is seized	Disassemble, and correct the seized part with an oilstone, or replace the gripper with a new one.
	The piston does not operate.	Check that the air pressure is within the operating pressure range.
		Check for air leakage.
		Check the piping and solenoid valve, and if normal, disassemble and clean the cylinder.
The switch is faulty or installed incorrectly.	Check that the switch can detect normally.	
Lack of master jaw stroke	Much dust exists in master jaws.	Disassemble the gripper, clean it, replace the seals, and apply grease.
Low gripping force	Low air pressure	Check that the air pressure is within the operating pressure range.
	Air leaks from the seal.	Disassemble the gripper, clean it, replace the seals, and apply grease.
	Master jaw movements are not smooth.	Remove the cover and supply grease, and open and close the master jaws several times without gripping any conveyed workpiece.
		Disassemble the gripper, clean it, and apply grease.

WARNING

- If the gripper failed due to a seizure or damage, disassemble the gripper following the disassembly procedure. If the gripper is in the state that you cannot disassemble, do not disassemble it forcibly but please contact us or our agents.
- Stop using the gripper immediately if the situations are not improved though corrective actions given in above table were taken. Continuous use of faulty product or part could cause serious human accidents due to flying gripper or conveyed workpiece.
- The gripper must be repaired only by skilled persons who have received the training course. Repair by unskilled persons or persons other than us or our agents could cause serious human accidents.

8-2. Contact address in case of trouble

Please get in touch with our sales agent from which you purchased the gripper or our office when the gripper troubled.

9. Others

9-1. Standards and directives to which the gripper conforms

This product conforms to the following standards and directives:

- Machinery Directive:2006/42/EC Annex I
- EN ISO 12100:2010

9-2. Disposal of gripper

Dispose of this unit in accordance with the laws and regulations of your country.